

Advanced Deep Excavation Workshop 5-Feb-2025



DEEP EXCAVATION
RELIABLE GEOEXPERTISE

Introduction

- Why this workshop
- Presenters



Dimitrios Konstantakos

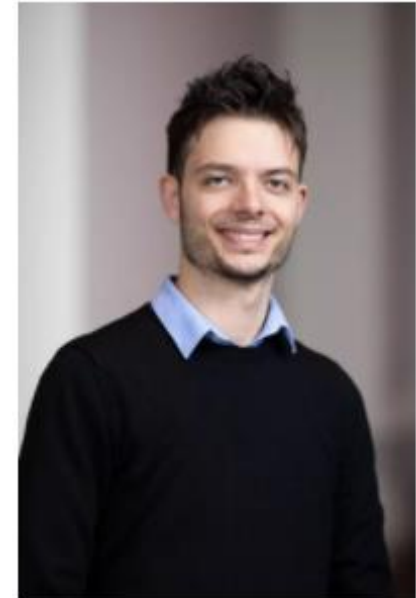

Dr. Nikolaos Lesgidis



Topics

- Optimization
- MSE Walls, pile abutments
- Finite element analysis – theoretical background and applications
- Design of sea walls
- Marine projects design methods
- Advanced 3D frame analysis
- Steel connections
- Practice – software applications

1.1 Support Location Optimization

- Obtain a range of optimized support locations
- 30ft deep excavation
- 2 levels of tiebacks

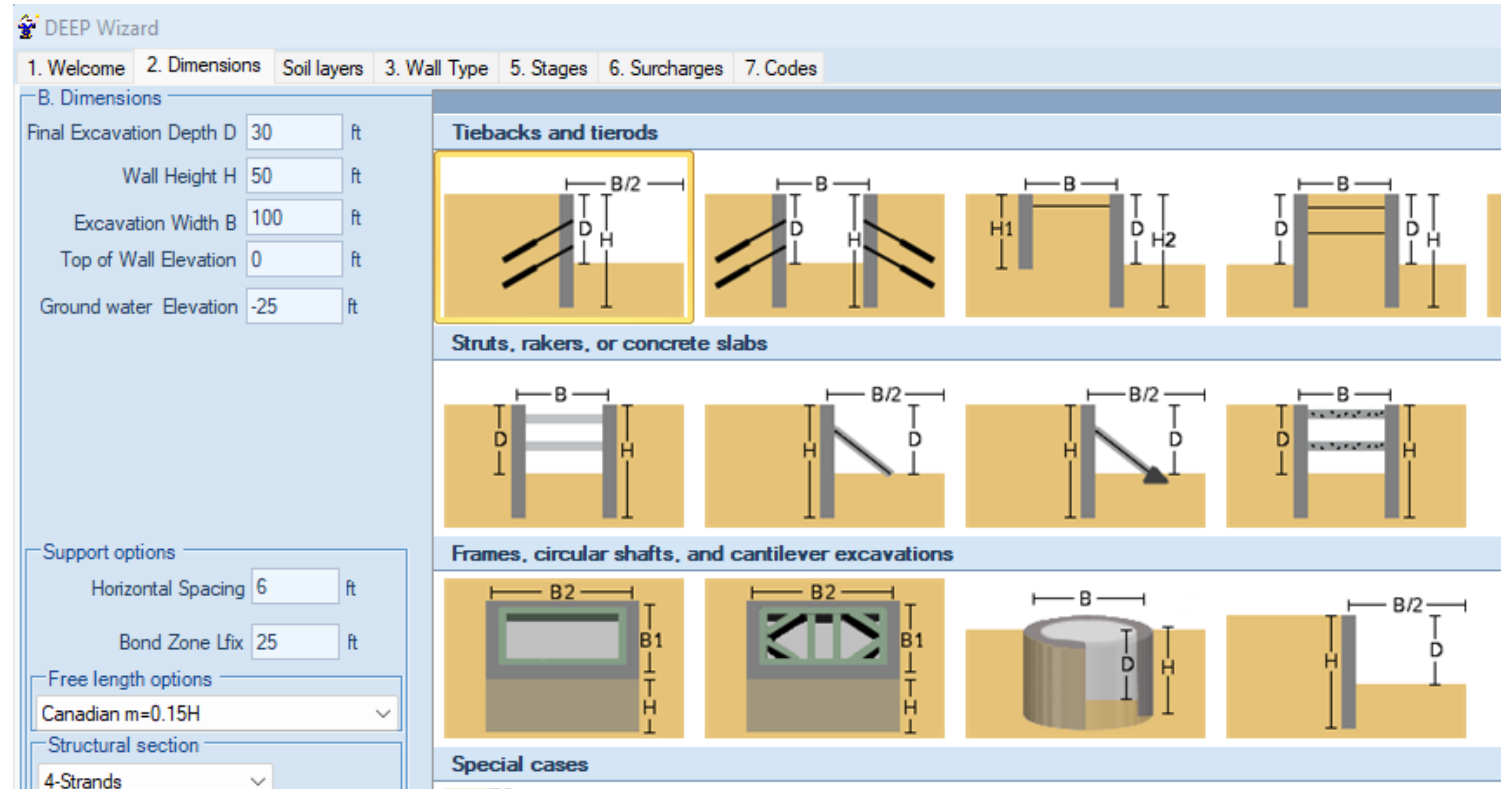

1.2 Optimization Options

- Optimize tab:

Model Optimizer

With this tool you can have DeepEX search for the optimal location of a support. This analysis will take time once you select "Optimize Model".

1. For One Support 2. Multiple Supports 3. Preferred Wall Sizes

Support	Use Elevations	Elevation	Start Depth or EL	End Depth or EL	Hor. Spacing and Angle
0, on wall 0	<input checked="" type="checkbox"/>	-8	-5	-11	Edit
1, on wall 0	<input checked="" type="checkbox"/>	-19	-16	-22	Edit
*	<input type="checkbox"/>				

Generate for all supports

Maximum threads
32

3. Optimization Options

Control horizontal wall displacement

Depth increment 2 ft

Limit Hor. Wall Dx 1.5 in

Perform Multi Thread Iteration

Full wall optimization for each run

Optimize model OK Cancel

1.3 Results

Ventures\00 DeepEX_Development\00 Manuals_Technical (NEW)\09 Workshops\230403 Advanced DeepEX\230403 Section 3.1.D...

1SE Stability+ Design Results Report View Optimize 3D-World Monitoring Help

design wall
Autodesign fix for a ground an
Geotechnical o

Select which configuration you would like

Design section optimization results

Supports at El. -7, -21, Mmax=20.93k-ft/ft, Wall Length= 44.5ft, Support reaction = 13.25k/ft, Cost= 8927742.33\$, dx= 0.125inSteel SheetsDES: SCZ 14, Sxx= 14.36 in3/ftFy'Sheet = 50 ksi
Supports at El. -6, -20, Mmax=22.35k-ft/ft, Wall Length= 44.5ft, Support reaction = 12.22k/ft, Cost= 8945789.5\$, dx= 0.115inSteel SheetsDES: SCZ 14, Sxx= 14.36 in3/ftFy'Sheet = 50 ksi
Supports at El. -7, -20, Mmax=22.47k-ft/ft, Wall Length= 45ft, Support reaction = 12.93k/ft, Cost= 8927903.2\$, dx= 0.126inSteel SheetsDES: SCZ 14, Sxx= 14.36 in3/ftFy'Sheet = 50 ksi
Supports at El. -7, -22, Mmax=24.58k-ft/ft, Wall Length= 44ft, Support reaction = 14.29k/ft, Cost= 8945859.41\$, dx= 0.13inSteel SheetsDES: SCZ 14, Sxx= 14.36 in3/ftFy'Sheet = 50 ksi
Supports at El. -6, -21, Mmax=24.84k-ft/ft, Wall Length= 44.5ft, Support reaction = 12.94k/ft, Cost= 8955555.19\$, dx= 0.129inSteel SheetsDES: SCZ 14, Sxx= 14.36 in3/ftFy'Sheet = 50 ksi
Supports at El. -5, -19, Mmax=24.89k-ft/ft, Wall Length= 45ft, Support reaction = 12.83k/ft, Cost= 8948804.82\$, dx= 0.145inSteel SheetsDES: SCZ 14, Sxx= 14.36 in3/ftFy'Sheet = 50 ksi
Supports at El. -6, -19, Mmax=25.07k-ft/ft, Wall Length= 45ft, Support reaction = 12.17k/ft, Cost= 8948988.82\$, dx= 0.146inSteel SheetsDES: SCZ 14, Sxx= 14.36 in3/ftFy'Sheet = 50 ksi
Supports at El. -7, -19, Mmax=25.25k-ft/ft, Wall Length= 45ft, Support reaction = 12.68k/ft, Cost= 8954399.36\$, dx= 0.147inSteel SheetsDES: PAZ 4470, Sxx= 15.7 in3/ftFy'Sheet = 50 ksi
Supports at El. -5, -20, Mmax=25.46k-ft/ft, Wall Length= 44.5ft, Support reaction = 12.77k/ft, Cost= 8989718.33\$, dx= 0.132inSteel SheetsDES: PAZ 4470, Sxx= 15.7 in3/ftFy'Sheet = 50 ksi
Supports at El. -8, -22, Mmax=26.39k-ft/ft, Wall Length= 44ft, Support reaction = 14.59k/ft, Cost= 8960291.45\$, dx= 0.198inSteel SheetsDES: PAZ 4470, Sxx= 15.7 in3/ftFy'Sheet = 50 ksi
Supports at El. -8, -20, Mmax=26.4k-ft/ft, Wall Length= 45ft, Support reaction = 13.76k/ft, Cost= 8946927.01\$, dx= 0.19inSteel SheetsDES: PAZ 4470, Sxx= 15.7 in3/ftFy'Sheet = 50 ksi
Supports at El. -8, -19, Mmax=26.4k-ft/ft, Wall Length= 45ft, Support reaction = 13.58k/ft, Cost= 8945805.93\$, dx= 0.191inSteel SheetsDES: PAZ 4470, Sxx= 15.7 in3/ftFy'Sheet = 50 ksi
Supports at El. -8, -21, Mmax=26.4k-ft/ft, Wall Length= 44.5ft, Support reaction = 13.96k/ft, Cost= 8957655.58\$, dx= 0.194inSteel SheetsDES: PAZ 4470, Sxx= 15.7 in3/ftFy'Sheet = 50 ksi
Supports at El. -5, -18, Mmax=27.83k-ft/ft, Wall Length= 45ft, Support reaction = 12.89k/ft, Cost= 8976411.06\$, dx= 0.183inSteel SheetsDES: PAZ 4470, Sxx= 15.7 in3/ftFy'Sheet = 50 ksi
Supports at El. -6, -18, Mmax=28.04k-ft/ft, Wall Length= 45ft, Support reaction = 12.2k/ft, Cost= 8978349.66\$, dx= 0.184inSteel SheetsDES: PAZ 4470, Sxx= 15.7 in3/ftFy'Sheet = 50 ksi
Supports at El. -7, -18, Mmax=28.25k-ft/ft, Wall Length= 45.5ft, Support reaction = 12.45k/ft, Cost= 8964385.46\$, dx= 0.185inSteel SheetsDES: PAZ 4470, Sxx= 15.7 in3/ftFy'Sheet = 50 ksi
Supports at El. -8, -18, Mmax=28.48k-ft/ft, Wall Length= 45.5ft, Support reaction = 13.41k/ft, Cost= 8957546.64\$, dx= 0.193inSteel SheetsDES: PAZ 4470, Sxx= 15.7 in3/ftFy'Sheet = 50 ksi
Supports at El. -5, -21, Mmax=30.29k-ft/ft, Wall Length= 44.5ft, Support reaction = 12.72k/ft, Cost= 9056092.66\$, dx= 0.177inSteel SheetsDES: PAZ 5470, Sxx= 20.9 in3/ftFy'Sheet = 50 ksi
Supports at El. -6, -22, Mmax=30.56k-ft/ft, Wall Length= 44ft, Support reaction = 13.65k/ft, Cost= 9045412.36\$, dx= 0.183inSteel SheetsDES: PAZ 5470, Sxx= 20.9 in3/ftFy'Sheet = 50 ksi
Supports at El. -5, -17, Mmax=30.99k-ft/ft, Wall Length= 45.5ft, Support reaction = 12.95k/ft, Cost= 9043338.51\$, dx= 0.224inSteel SheetsDES: PAZ 5470, Sxx= 20.9 in3/ftFy'Sheet = 50 ksi
Supports at El. -6, -17, Mmax=31.25k-ft/ft, Wall Length= 45.5ft, Support reaction = 12.22k/ft, Cost= 9033803.6\$, dx= 0.226inSteel SheetsDES: PAZ 5470, Sxx= 20.9 in3/ftFy'Sheet = 50 ksi
Supports at El. -7, -17, Mmax=31.51k-ft/ft, Wall Length= 45.5ft, Support reaction = 12.22k/ft, Cost= 9026322.85\$, dx= 0.231inSteel SheetsDES: PAZ 5470, Sxx= 20.9 in3/ftFy'Sheet = 50 ksi
Supports at El. -8, -17, Mmax=31.79k-ft/ft, Wall Length= 45.5ft, Support reaction = 13.28k/ft, Cost= 9021153.04\$, dx= 0.233inSteel SheetsDES: PAZ 5470, Sxx= 20.9 in3/ftFy'Sheet = 50 ksi
Supports at El. -9, -21, Mmax=32.62k-ft/ft, Wall Length= 44.5ft, Support reaction = 14.88k/ft, Cost= 9002549.34\$, dx= 0.283inSteel SheetsDES: PAZ 5470, Sxx= 20.9 in3/ftFy'Sheet = 50 ksi
Supports at El. -9, -22, Mmax=32.62k-ft/ft, Wall Length= 44.5ft, Support reaction = 15.27k/ft, Cost= 9011501.93\$, dx= 0.283inSteel SheetsDES: PAZ 5470, Sxx= 20.9 in3/ftFy'Sheet = 50 ksi
Supports at El. -9, -19, Mmax=32.63k-ft/ft, Wall Length= 45ft, Support reaction = 14.65k/ft, Cost= 9008222.61\$, dx= 0.279inSteel SheetsDES: PAZ 5470, Sxx= 20.9 in3/ftFy'Sheet = 50 ksi

OK Cancel

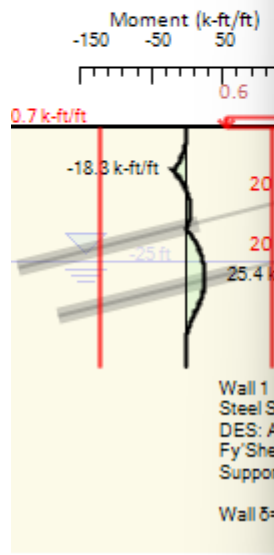

2. MSE Walls

- 2024 Version MSE Wizard
- Automatic selection
- Coherent method
- AASHTO Stiffness
- Allen Stiffness

2.1 Use Wizard

DEEP Wizard

1. Welcome 2. Dimensions Soil layers 3. Wall Type 5. Stages 6. Surcharges 7. Codes

B. Dimensions

Ground water Elevation -22 ft

H2 22 ft

Initial ground El. 0 ft

Support options

Bond Zone Lfix 20 ft

Tiebacks and tiers

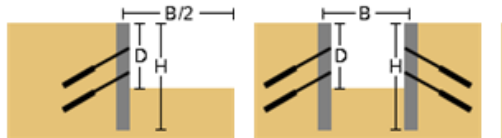

Struts, rakers, or concrete slabs



Frames, circular shafts, and cantilever excavations

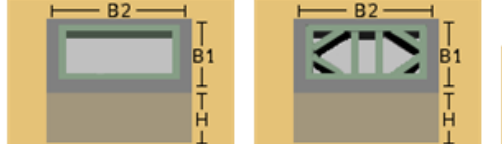

Special cases

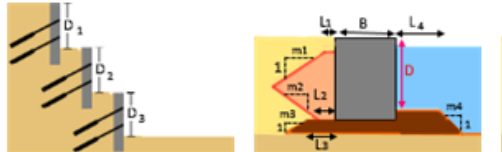

MSE

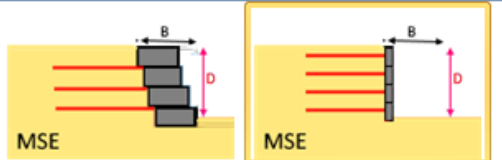

MSE Reinforcement

Panel Length 5 ft

Reinforcement Spacing 2.5 ft

Panel embedment 2 ft

Model only last stage

Reinforcement type Steel strips or grids

Section SteelStrip 0

MSE Calculations Automatic selection (Coherent for steel, otherwise simp)

This is a permanent wall

Specify backfill zone BF Set typical backfill

2.3 MSE Wall Options

Soil reinforcement analysis options for MSE walls

Pressure Methods
Automatic selection (Coherent for steel, otherwise simplified stiffness)

Coherent pressures Ko x Kr at top and Ka x factor below (more conservative)

Examine mobilization with simplified LEM Bishop method

Parameter selection
Use stage options for all soil reinforcements

Use force from MSE methods when used

Strength Pressure factors

Strength options

Minimum divisions for each reinforcement 10

Division length 1

Installation damage reduction factor Rf.i 1.4

Creep reduction factor Rf.c 1.4

Durability reduction factor Rf.d 1.7

Specify additional structural capacity loss

Use Zinc corrosion protection

Geotechnical safety factor FS.geo 1.5

Apply settings to stages

Apply to all stages

Apply to one stage Stage 2

Apply to stages From stage Stage 0 To stage Stage 3

OK Cancel

Soil reinforcement analysis options for MSE walls

Pressure Methods
Automatic selection (Coherent for steel, otherwise simplified stiffness)

Coherent pressures Ko x Kr at top and Ka x factor below (more conservative)

Examine mobilization with simplified LEM Bishop method

Use midpoint between supports (semirigid walls). Uncheck for flexible fac FS.Rotational 1.5

Use stiffness approach based on intersected length

Store search surfaces

Parameter selection
Use stage options for all soil reinforcements

Use force from MSE methods when used

Strength Pressure factors

Coherent pressures

	Generic	Steel strips	Steel Wire Grids
Top factor on Ko	1.5	1.7	2.5
depth to Ka	20	20	20
Factor on Ka 1	1	1.2	1.2

Stiffness method pressures AASHTO and Allen 2018 method for Dmax

Apply settings to stages

Apply to all stages

Apply to one stage Stage 2

Apply to stages From stage Stage 0 To stage Stage 3

OK Cancel

2.4 MSE Simplified Mobilization

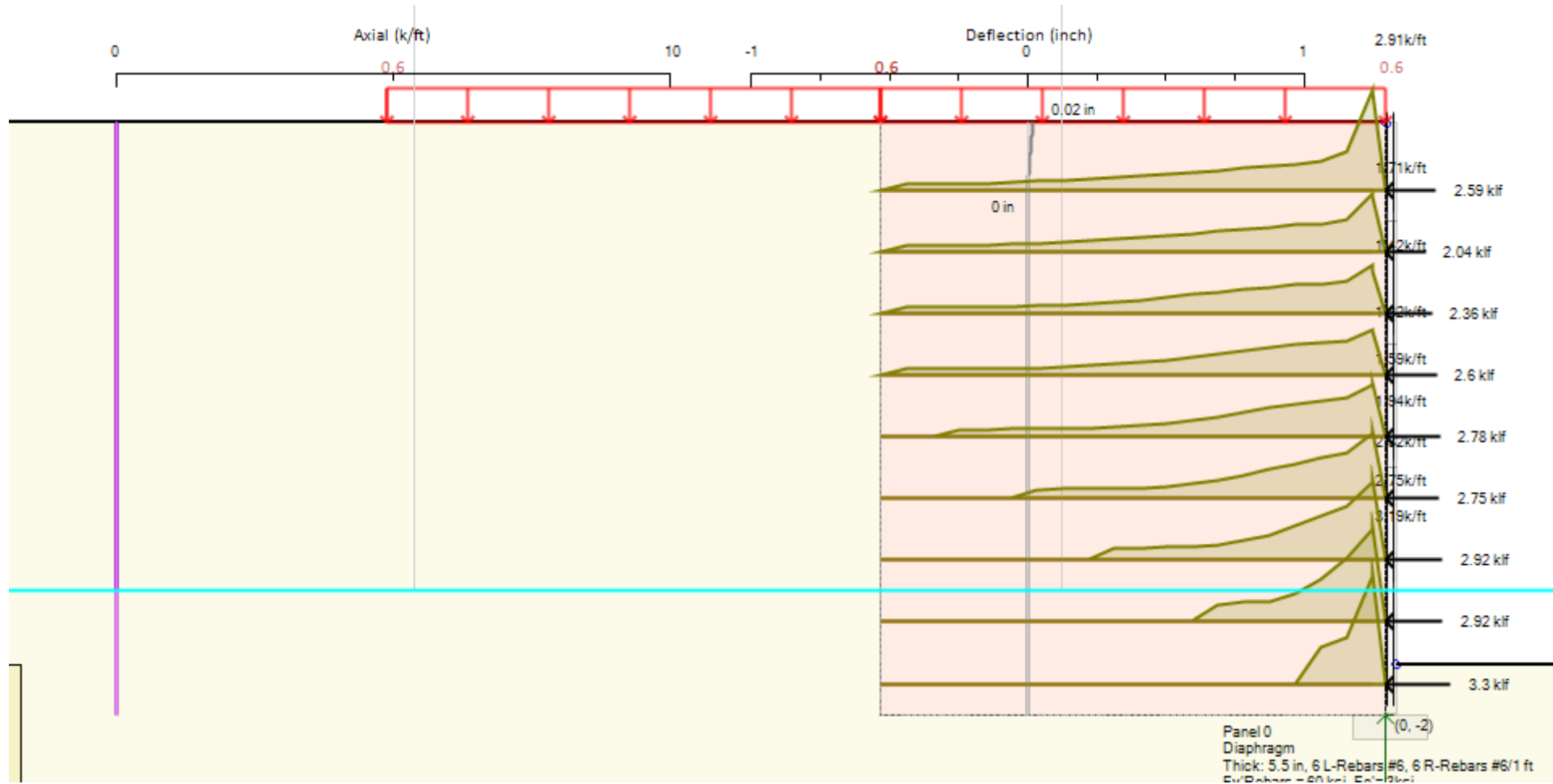

2.5 Adding an Impact Barrier

- Add wall on the left
- Draw impact load

The screenshot shows the 'Edit Wall Data' window with the 'Retaining Wall Data' dialog open. The dialog has several tabs: 'Dimensions', 'Materials', 'Results', and 'Descriptions'. The 'Dimensions' tab is active, showing the following settings:

- Height: 6 ft
- Base: 6 ft
- Top Width: 2 ft
- Distance to left Top corner: 2 ft
- Heel Thick: 2 ft
- Toe width: ft
- Toe Thick: 2 ft
- Heel width: ft

There are also checkboxes for 'Use key', 'Drain back face', and 'Use a rectangular cap at the top'. The 'Descriptions' tab shows the wall name 'RT Wall 0' and a reinforcement table.

Use	P1	P2	Rebar	S(in)	No.	Clear(in)	Ast(in2)
<input checked="" type="checkbox"/>	A	B	#3	6	1	3	0.11
<input checked="" type="checkbox"/>	B	C	#3	6	1	3	0.11
<input checked="" type="checkbox"/>	C	D	#3	6	1	3	0.11
<input checked="" type="checkbox"/>	D	E	#3	6	1	3	0.11
<input checked="" type="checkbox"/>	E	F	#3	6	1	3	0.11
<input checked="" type="checkbox"/>	F	G	#3	6	1	3	0.11
<input checked="" type="checkbox"/>	G	H	#3	6	1	3	0.11
<input checked="" type="checkbox"/>	H	A	#3	6	1	3	0.11

2.6 MSE Impact Load

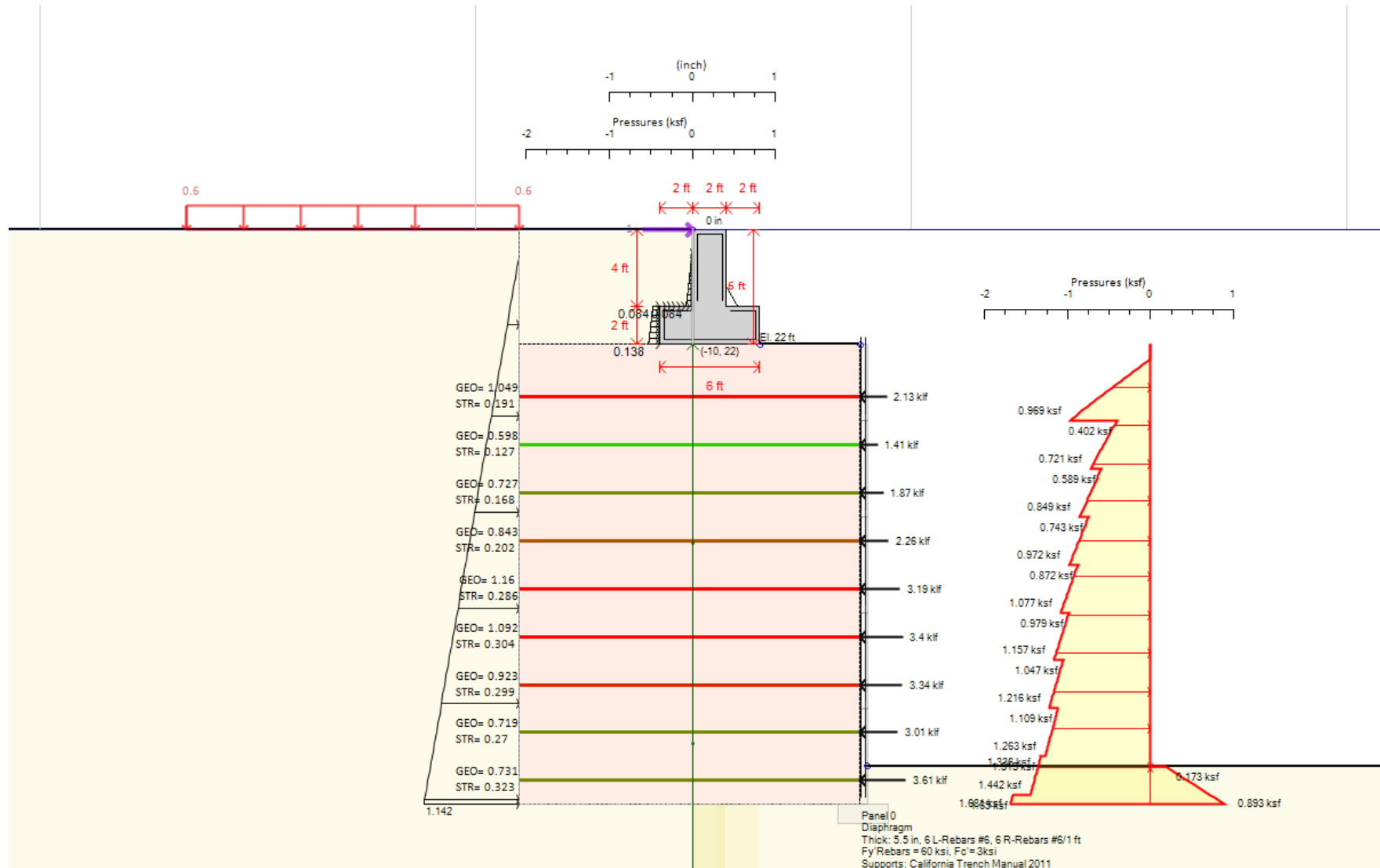

3. Seawalls and Wave Pressures

- Introduction to wave pressures
- Gravity walls
- Caisson walls



3.1.1 Wave Pressures - Shoreward

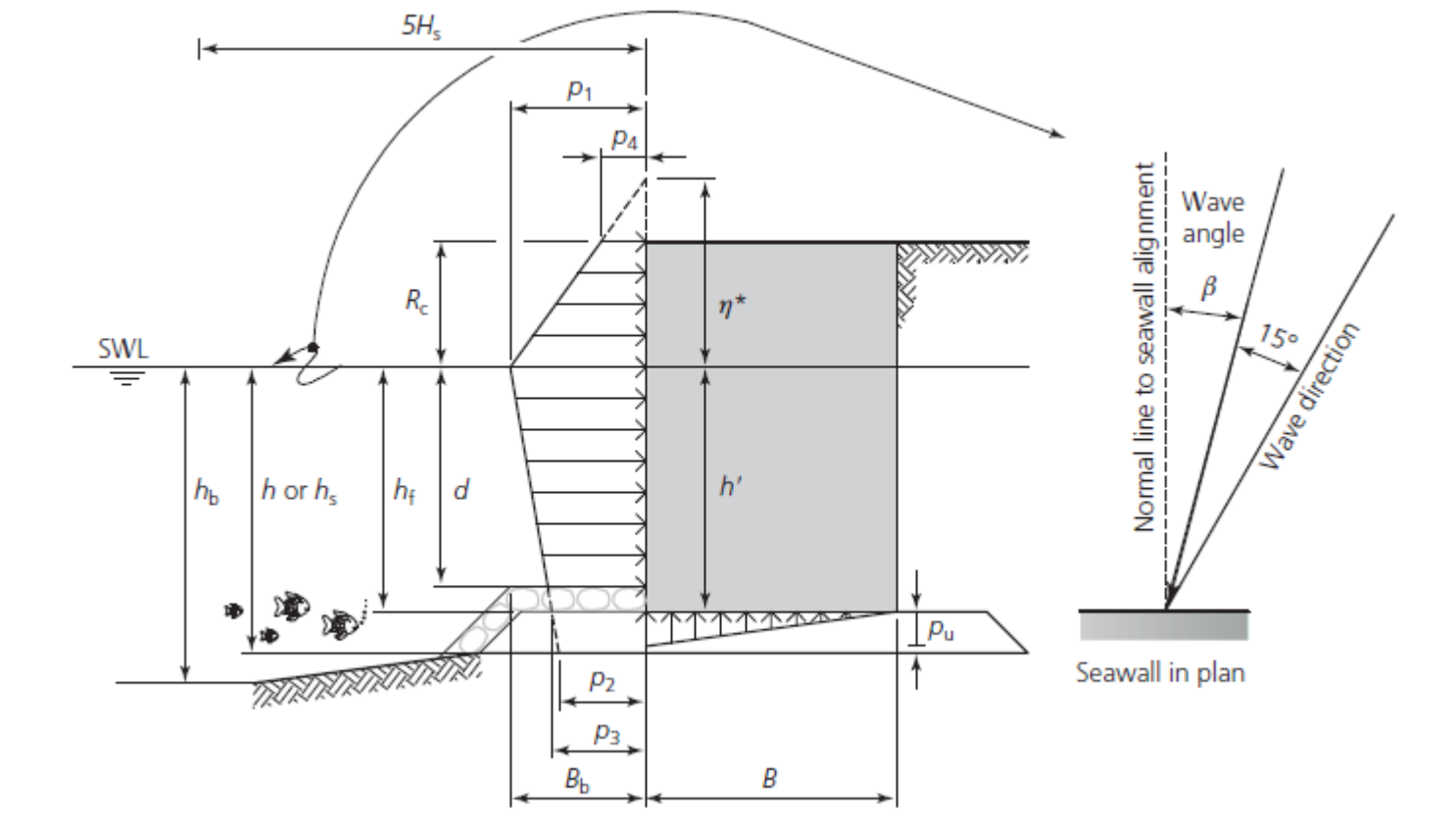

Goda's Wave Pressures

3.1.2 Wave Pressures - Seaward

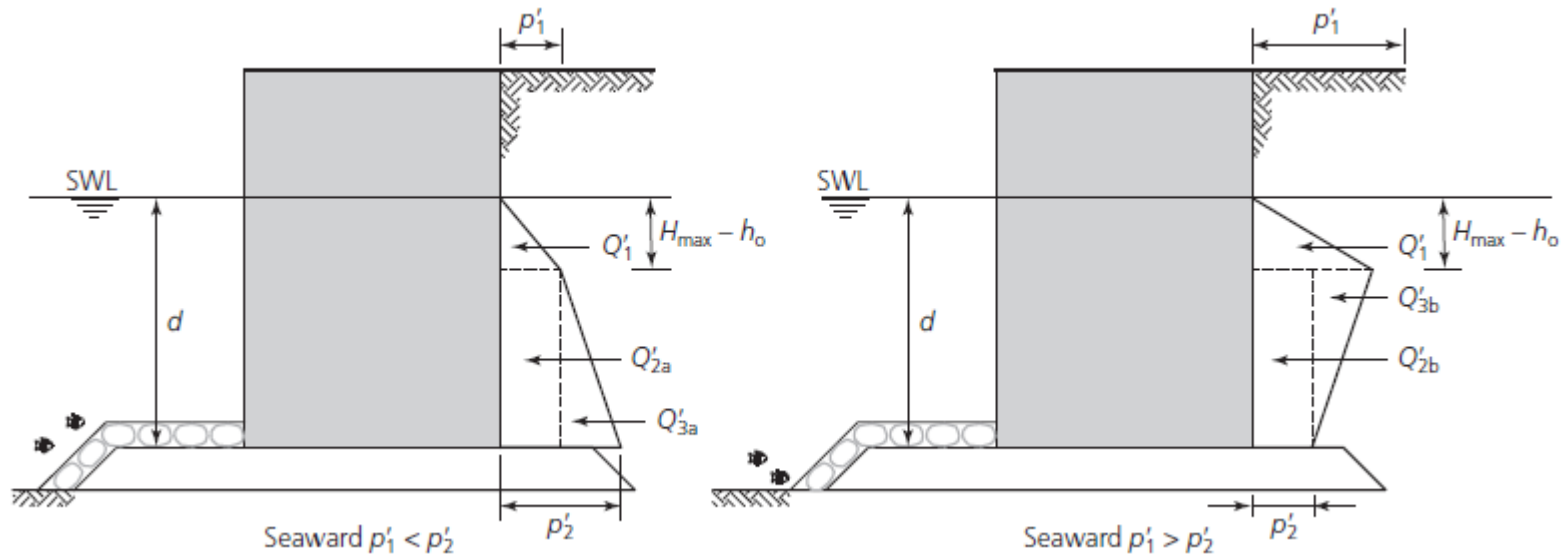

Sainflou wave pressures

3.1.3 Impact vs. Pulsating Waves

PROVERBS (European 1999)

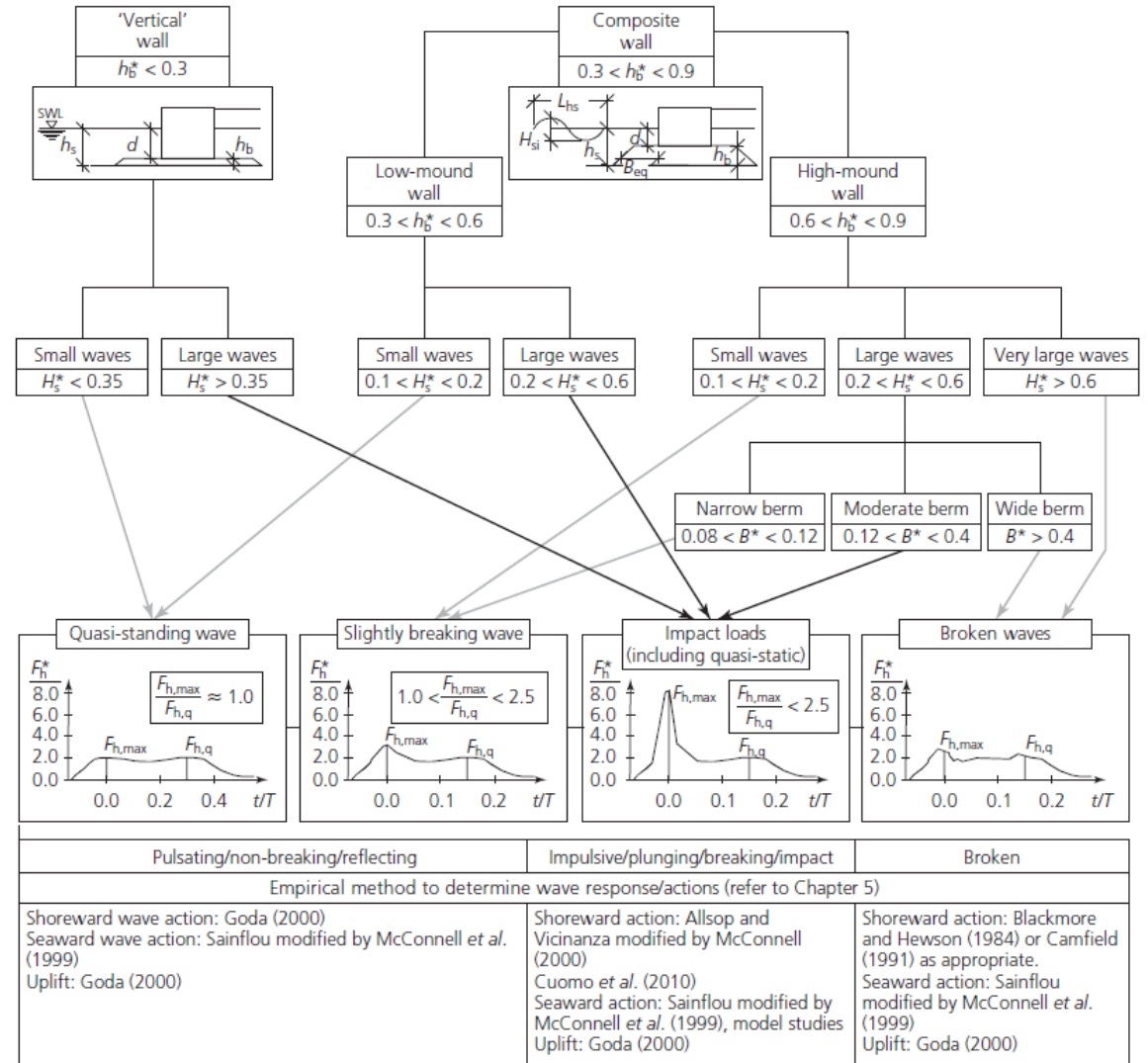

With $h_b^* = \frac{h_b}{h_s}$, $H_s^* = \frac{H_{si}}{h_s}$, $B^* = \frac{B_{eq}}{L_{hs}}$, $F_h^* = \frac{F_h}{\rho \cdot g \cdot H_s^2}$

3.2.1 Gravity Wall Example

DEEP Wizard

1. Welcome 2. Dimensions Soil layers 3. Wall Type 6. Surcharges 7. Codes

B. Dimensions

L1 25 ft m1 1.5
 L2 15 ft m2 1.5
 L3 15 ft m3 1.5
 L4 30 ft m4 1.5
 h1 10 ft
 Base ground E. -60 ft
 Tidal lag water difference 5 ft
 Final Excavation Depth D 45 ft
 Wall Height H 50 ft
 Excavation Width B 100 ft
 Top of Wall Elevation 10 ft
 Ground water Elevation 0 ft

Tiebacks and tierods

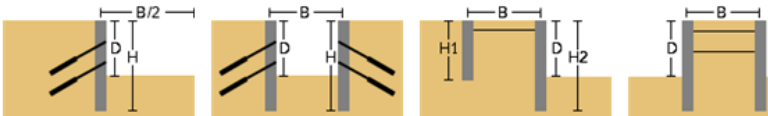

Struts, rakers, or concrete slabs

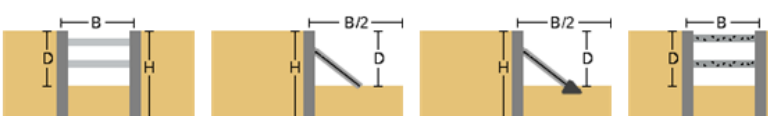

Frames, circular shafts, and cantilever excavations



Special cases

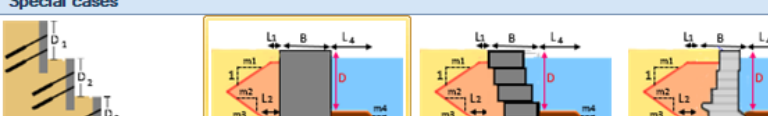

Structural Properties

Estimate structural properties for tiebacks Pult= 0.40 $\gamma \times h \times s$
 Include prestress force for tiebacks (with beam-on-elastic foundations solution). 0.18 $\gamma \times h \times s$

DEEP Wizard

1. Welcome 2. Dimensions Soil layers 3. Wall Type 6. Surcharges 7. Codes

Please define your basic soil types. Soil types are used in borehole records (borings). Define soils from text description

1. Edit soil types

Note: For estimation only, you can describe your soil stratigraphy with simple language. DeepEX will estimate all properties! Not a substitute for a thorough geotechnical investigation!

Please define an approximate soil layer stratigraphy (boring). A boring uses soil types and top of layer elevations.

2. Edit borings **Available wall sections**
1: Boring 1

3. Edit SPT records **Assign an SPT record**
Not selected/default

When using SPT's you still need to define the unit weights of each soil type. Effective cohesion for mixed soils cannot be estimated.

If an SPT record is assigned, then use SPT to estimate as many different parameters along the pile depth.

4. Assign layers for quay wall fill zones

Fill soil type F
 Relief prism soil type RF Select add typical soil types for relief prism and base.
 Soil type for embankment and base GR
 Natural soil type below embankment F

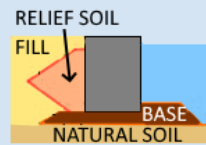

3.2.2 Gravity Wall Example - Loads

DEEP Wizard

1. Welcome 2. Dimensions Soil layers 3. Wall Type 6. Surcharges 7. Codes

Construction equipment or material stacking behind the excavation can cause additional loads on the support wall. Some typical surcharge loads used in practice are available below.

Use a two step wall surcharge

Use a triangular surcharge

Use a strip load ksf ft
Behind wall ft

Do not use a wall surcharge

Mooring Loads

Mooring load for operating conditions klf Ignore mooring loads

Mooring load for extreme conditions (high waves) klf

Mooring load for seismic conditions klf

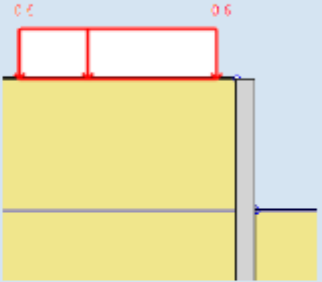

The diagram shows a cross-section of a gravity wall. The wall is represented by a vertical grey line. To the left of the wall is a yellow area representing soil. On top of the wall, there are two white rectangular blocks representing a strip load. Red arrows point to these blocks, with the value '0.6' written above each. Below the wall, there is a smaller yellow area representing a foundation or seabed. The text '0.6' is also written above the second block.

3.2.3 Wave Pressures – Sainflou, CEM

Wave analysis options

Design method: Sainflou 1928

Design wave Hinc: Leidraad (2.2 Hs)

Wall side to apply: Automatic

Wave inclination to wall normal: 0 deg

Significant wave height Hs: 3 ft

Local wave height H: 3 ft

Peak period Tp: 9 sec

Wave length method: User defined

Wave length: 100 ft

Overtopping: Do not calculate overtopping

DEEP Wizard

1. Welcome 2. Dimensions 3. Wall Type 6. Surcharges 7. Codes

1. Structural Codes

Use US Allowable Stress Design for Steel (ACI for concrete)

Typical Wave Heights

Condition	Min wave height Hmin (m)	Max. wave height Hmax (m)	Wave Period Tmin (sec)	Max. Period Tmax (sec)	Suggested Wave Height Hrec (m)	Suggested wave period T (sec)	Select
Individual thunderstorm	0.5	1.5	1.5	3	1.4	2.8	Select
Supercell thunderstorm	2	3	3	6	2.9	5	Select
Sea breeze	0.5	1.5	3	4	1.4	3.5	Select
Lee waves	0.5	1.5	2	5	1.4	4.5	Select
Front squall lines	1	5	4	7	4.5	6	Select
Tropical depression	1	4	4	8	3.5	7	Select
Tropical storm	5	8	5	9	7.5	8	Select
Hurricane Simpson Scale 1	4	8	7	11	7.5	10	Select
Hurricane Simpson Scale 2	6	10	9	12	9.5	11	Select
Hurricane Simpson Scale 3	8	12	11	13	11.5	12	Select
Hurricane Simpson Scale 4	10	14	12	15	13.5	14	Select
Hurricane Simpson Scale 5	10	14	12	15	13.5	14	Select
Weak Extratropical Cyclone	3	5	5	10	4.5	8	Select
Moderate Extratropical Cyclone	5	8	9	13	7.5	11	Select
Intense Extratropical Cyclone	8	12	12	17	11.5	15	Select
Extreme Extratropical Cyclone	13	18	15	20	17	17.5	Select
Monsoonal winds	4	7	6	11	6.5	9	Select

Significant wave height Hs: 31.99 ft

Local wave height H: 21.33 ft

Peak period Tp: 9 sec

3.2.4 Seismic Pressures

- Seismic earth pressures
- Hydrodynamic pressures on seaside
- Mononobe-Okabe pressures
- Importance factor

Seismic Effects for Both Walls

1. Design Accelerations
 Include seismic effects in this stage
AxDesign= 0.1 g AzDesign= 0 g

2. Base Acceleration and site effects
2.a Building Code Options
 Use a Building Code Building Code: None
Soil Type Class: None
2.b Base Acceleration and Site Effects
Base Acceleration AxBase= 0 g Site Soil Response Factor Ss= 1
Topographic Site Response St= 1
Importance Factor I= 1

3. Wall Behavior and Response R factor
3.a Basic Wall Behavior
 Flexible Rigid (Wood Method)
3.b. Flexible Wall Behavior - R calculations
 R= User R according to Richards Elms
 R according to Building Code R according to Liao Whitman
3.c Specific R method options
3.c.1: R value (Structure Response)
R= 1

4. Seismic Thrust Options
Seismic pressures added as external pressures
 Semirigid (qEQ= aDesign x B x Sv_total) B= 0.75
 Mononobe-Okabe (Only frictional soils, a = Adesign)
Trapezoidal distribution
 User defined distribution
 User specified external pressures
 User defined with many points
Automatic Seismic Procedure (Use with R=1 see theory manual)
 Wood Manual (user specified classical)
 Wood Automatic (Auto for nonlinear method from Wood adjusted for wall deformations, Rect. Wood for Classic)

5. Water Behavior
 Pervious Impervious Automatic (EC8 Limits)
 Ignore free water hydrodynamic pressures
 Use actual water pressures for Hydrodynamic effects (0 to 1)

6. Height Options
 Calculate thrust to excavation subgrade. Calculate thrust to bottom of wall.

7. Wall Inertia Options
 Include wall inertia (for non gravity walls)

8. Apply General Settings
 Apply settings to all stages (except use of seismic)

Recalculate Design Accelerations OK Cancel

3.2.5 Gravity Wall Model

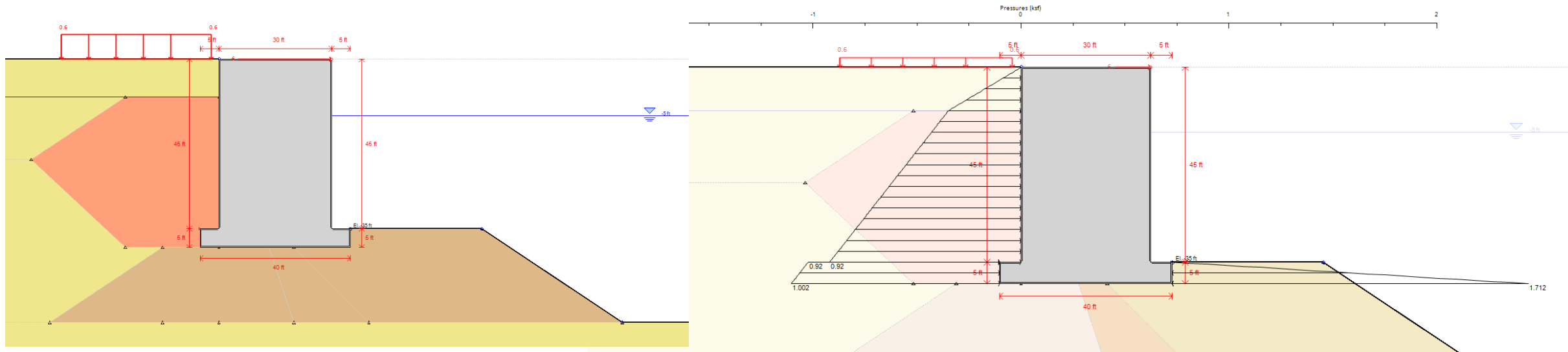

3.2.6 Wave & Seismic Pressures

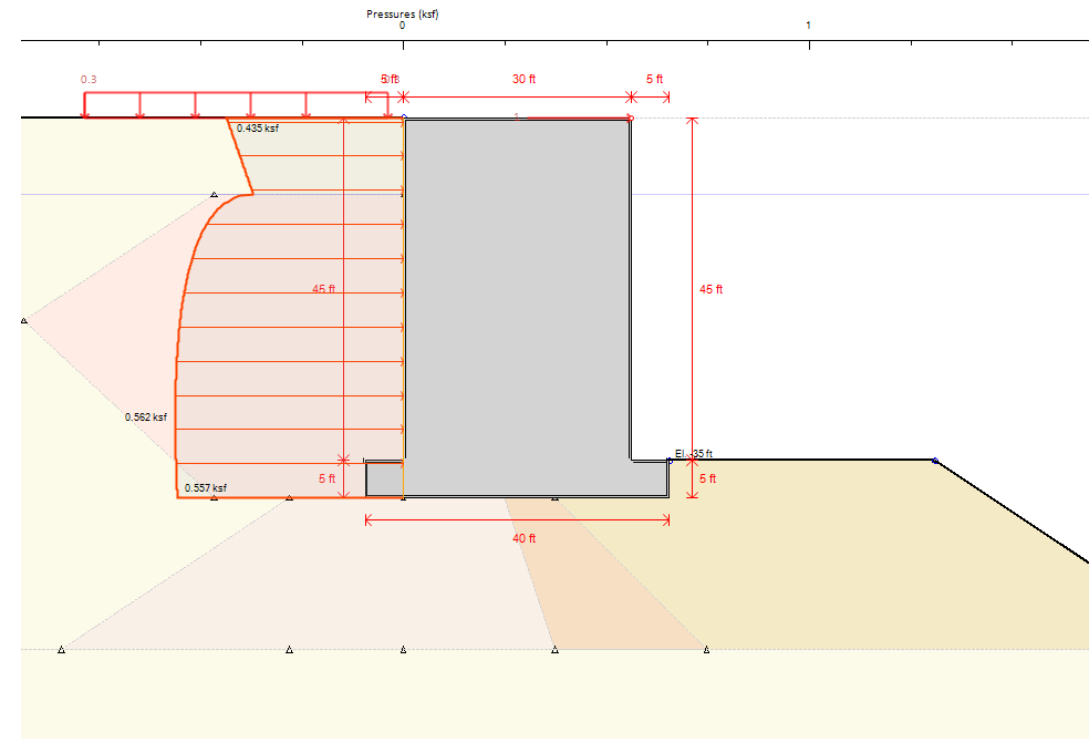
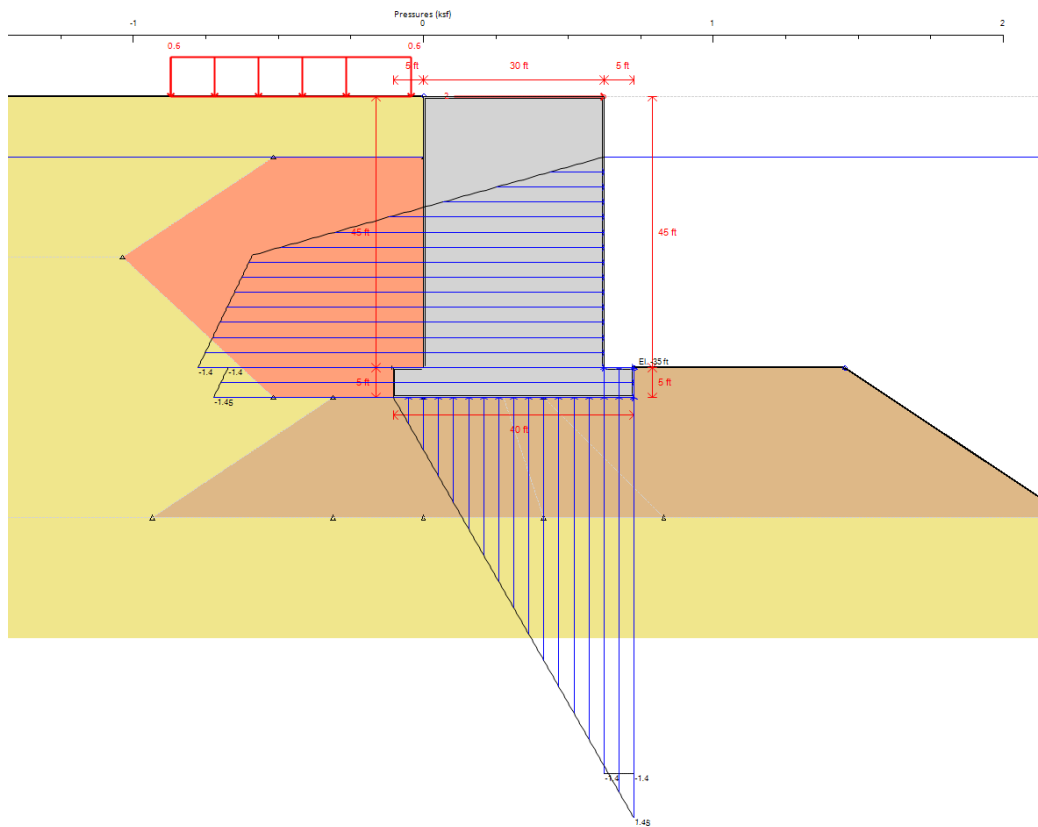

3.2.7 Bearing Capacity – Slope Stability

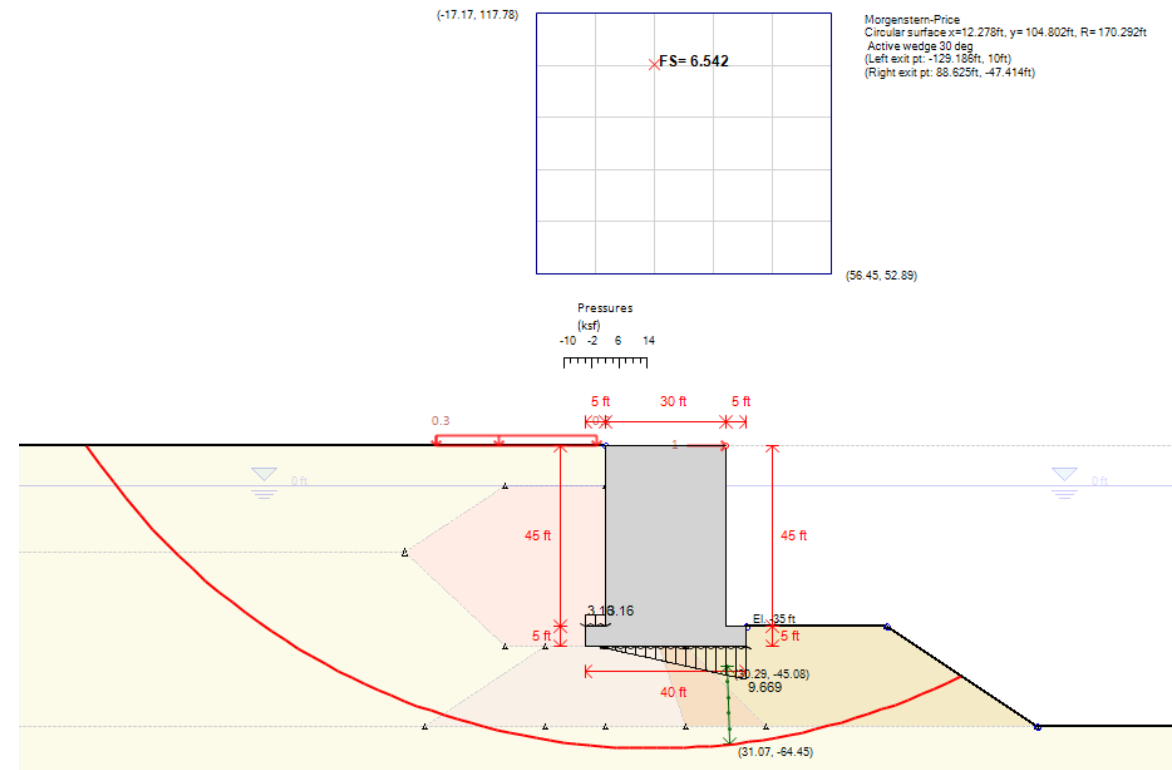
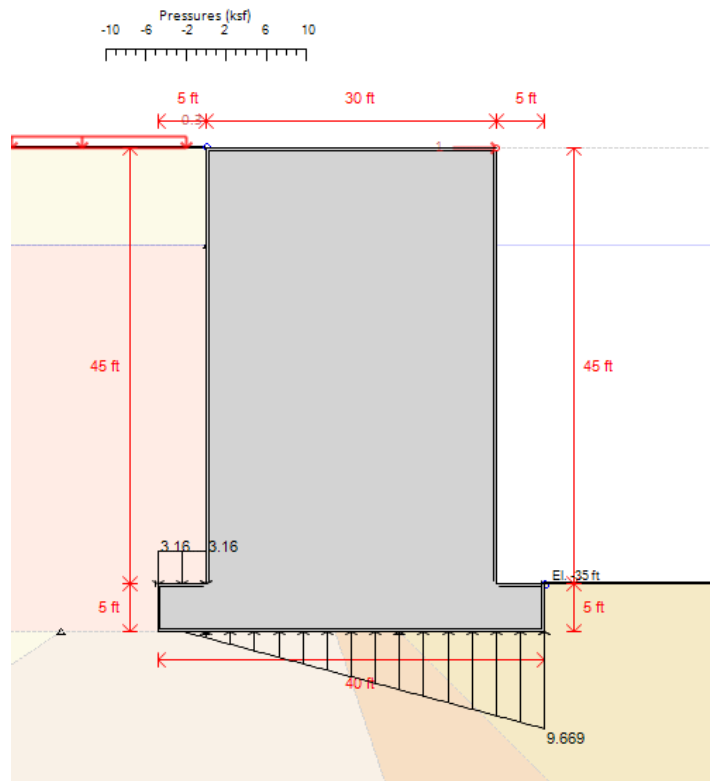

3.4.1 Floodwalls

- Use Gravity wall/Abutments
- Impact loads
- Wave pressures
- Local definitions

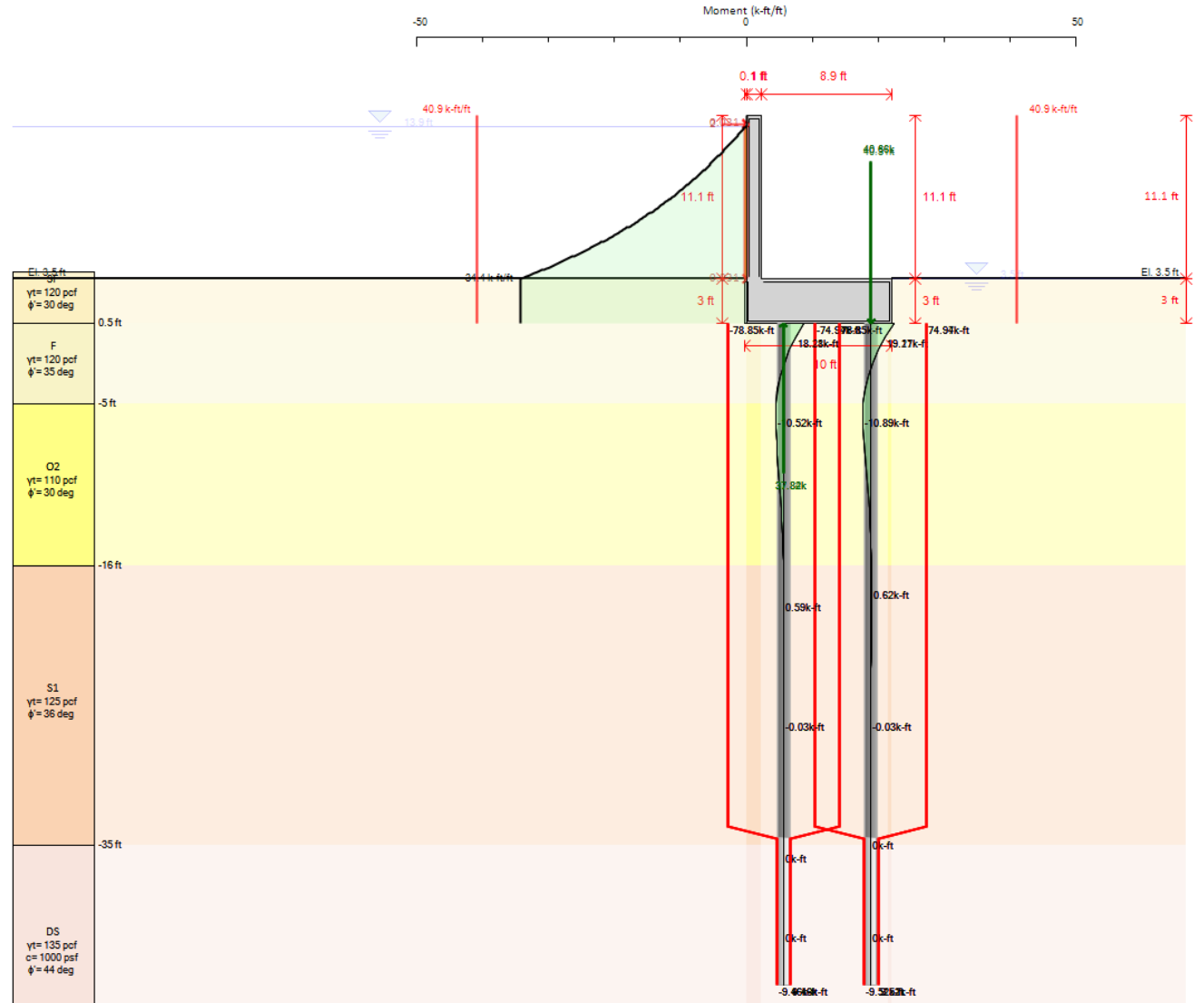

3.4.2 Abutment Wall (17.5 ft)

retaining wall Data

Select wall type

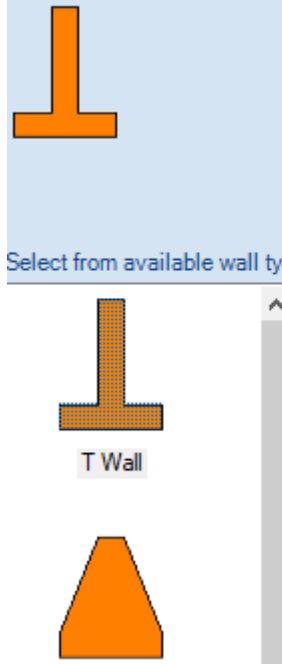

Select from available wall type

T Wall

Dimensions Piles (Abutments) Materials

Height 14.1 ft
Base 10 ft
Top Width 1 ft
Distance to left Top corner 0.1 ft
Heel Thick 3 ft
Toe width ft
Toe Thick 3 ft
Heel width ft

Wall No Gravity
1. Reinf
Use

Use key
 Drain back face
 Use a rectangular cap at the top

Dimensions Piles (Abutments) Materials Results Descriptions

All coordinates are local to the abutment wall

Pile Name	x	y	Length	Local Rotation	Angle from Horizontal	Lfree	Edit Pile
P1	2.5	7	45	0	90	1	Edit
P2	2.5	3.5	45	0	90	1	Edit
P3	2.5	-3.5	45	0	90	1	Edit
P4	2.5	-7	45	0	90	1	Edit
P5	8.5	7	45	0	90	1	Edit
P6	8.5	3.5	45	0	90	1	Edit
P7	8.5	-3.5	45	0	90	1	Edit
P8	8.5	-7	45	0	90	1	Edit
P9	8.5	0	45	0	90	1	Edit
P10	2.5	0	45	0	90	1	Edit



3.4.4 ASCE 7-22 Supplement 2

- Impact forces
- Load combinations
- Wave pressures
- Flow pressures

Flood Analysis Settings

Design method: ASCE/SEI 7-22

Wall side: Automatic

Water flow and debris impact settings

Water velocity flow options

Velocity distribution: Uniform with depth

Drag coefficient mode: User defined

drag coefficient Cd: 2 (typ. 1 to 2.5)

ASCE-SEI 7-22 Options

Risk Category: Category I

Water Elevation: Controlled from design section

Calculation for CMRI: ASCE/SEI 7-22

Location Type

Location type: Other coastal area

Debris Impact Options

Debris Impact Mode: ASCE 7-22 Selection

ASCE Load Type: Wood log pole

Height above water to apply: 0 ft

Damning closure: No damning closure

Impact distribution: Define distribution width

Impact distribution width: 80 ft

Apply settings to stages

Apply to all stages

Apply to one stage: Stage 1

Apply to stages: From stage: To stage:

Wall 0

OK Cancel

4. AI Generated Models

- Conversational AI
- Discuss with DeepEX AI assistant
- Suggestions on wall types, support types etc
- DeepEX assistant can create, run, and modify a model

4.1 AI Assistant

The screenshot displays the DeepEX 2025 software interface for a new project. The main design view shows a cross-section of a retaining wall system with the following dimensions and parameters:

- Top surface elevations: Left 0.00, Center -50.00, Right 0.00.
- Wall elevations: Left -16.40, Center -50.00, Right -16.40.
- Wall height: 65 ft.
- Wall segments: Drive (Ka=0.333, Kp=3), Resist (Ka=0.333, Kp=3), Drive (Ka=0.333, Kp=3).
- Soil parameters: $\gamma = 125 \text{ pcf}$, $\phi = 30 \text{ deg}$.
- Water table: $y = 62.4 \text{ pcf}$, Simple flow.
- Drainage: FHWA y/t, $K_m = 1.3$, $m = 0.3$.
- Resist: Kp.
- Wall 2 classic: California Shoring Manual-11.
- Drive: FHWA y/t, $K_m = 1.3$, $m = 0.3$.
- Resist: Kp.

Material and code specifications table:

Concrete Code:	ACI 318-19/1.5
Steel Code:	AISC 360-22 ALL
1st Wall Limit Equilibrium:	California Shoring Manual-11
Negative moment:	20%
Drain State Clays:	Default
Water $y = 62.4 \text{ pcf}$:	Simple flow
Drive:	FHWA y/t, $K_m = 1.3$, $m = 0.3$
Resist:	Kp
Wall 2 classic:	California Shoring Manual-11
Drive:	FHWA y/t, $K_m = 1.3$, $m = 0.3$
Resist:	Kp

Software interface details:

- Menu: General, Analysis, Seismic, Slope, MSE, Stability+, Design, Results, Report, View, Optimize, 3D-World, 3D-FEM, Monitoring, AI, Help.
- Toolbar: Model Wizard, Tunnel/Utilities Wizard, AI Assistant, Project Info, Move Model Elev., Dim.-Limits, Soil types, Structural sections, Edit Boring, Del right Wall, Edit 2nd wall, Surface Options, Wall Elevations, Add Stage, Delete Stage etc., Stage Dates: Start - End, Draw supports, Draw loads.
- Status Bar: Stage: 9/9, X: 151.73, Z: -73.33, (ft, in, k), 0.62H:1V.
- Calculation Progress: Analysis Log.
- Message: New file opened: C:\Deep Excavation\Visual Studio Software Development\git\DeepEX\DEEP\TX\data\Default.DEEP

5. Finite element theory and application

- Introduction to the finite element method
- Theoretical background
- Staging and initial conditions
- Soil constitutive laws
- structural components
- Meshing and analysis options
- Tunneling
- shear strength reduction analysis
- earthquake analysis

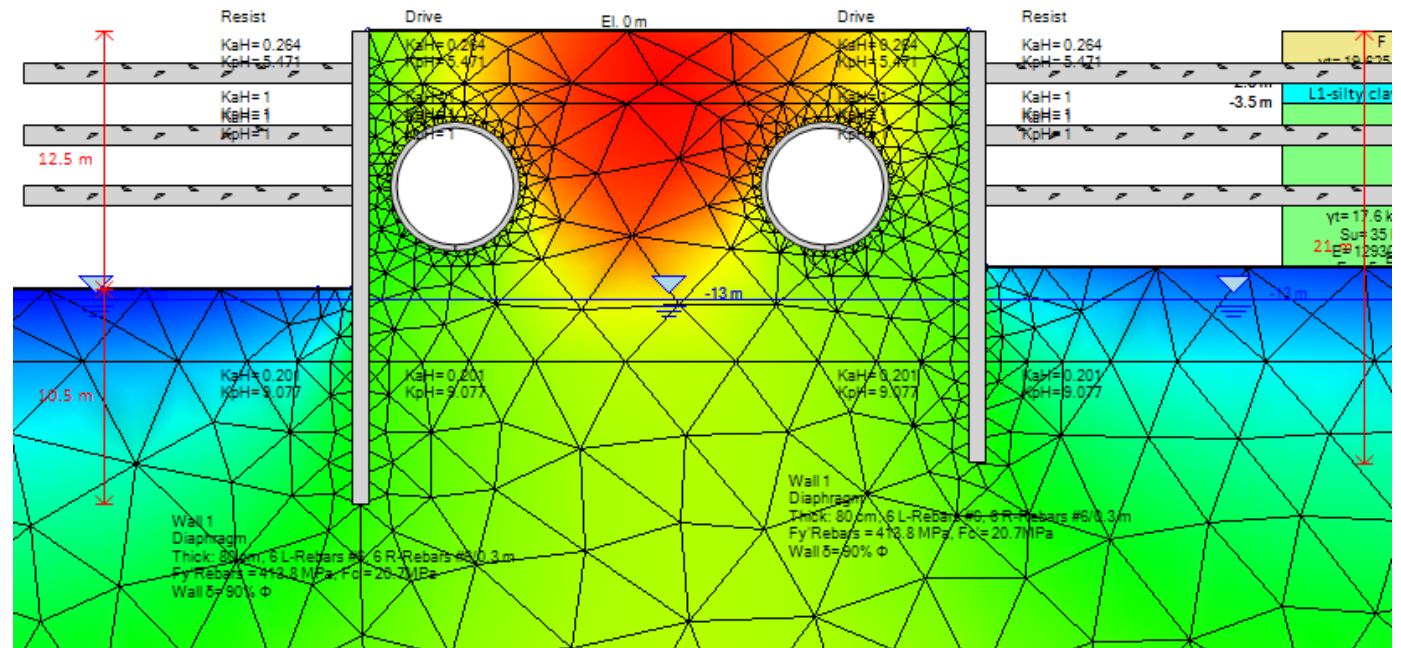

Introduction to the finite element method

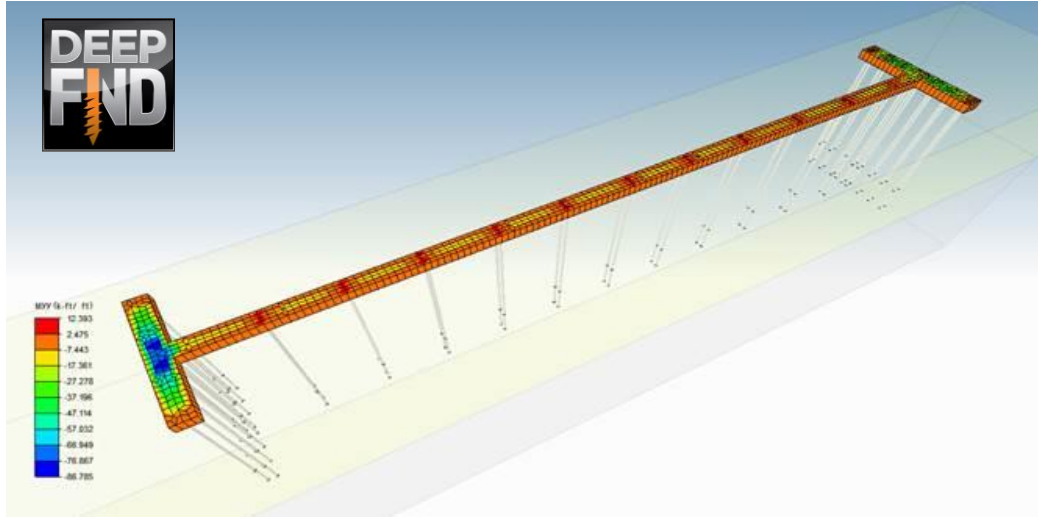

Cheap and fast way to forecast the project behavior.

Numerical simulations are part of everyday design tasks.

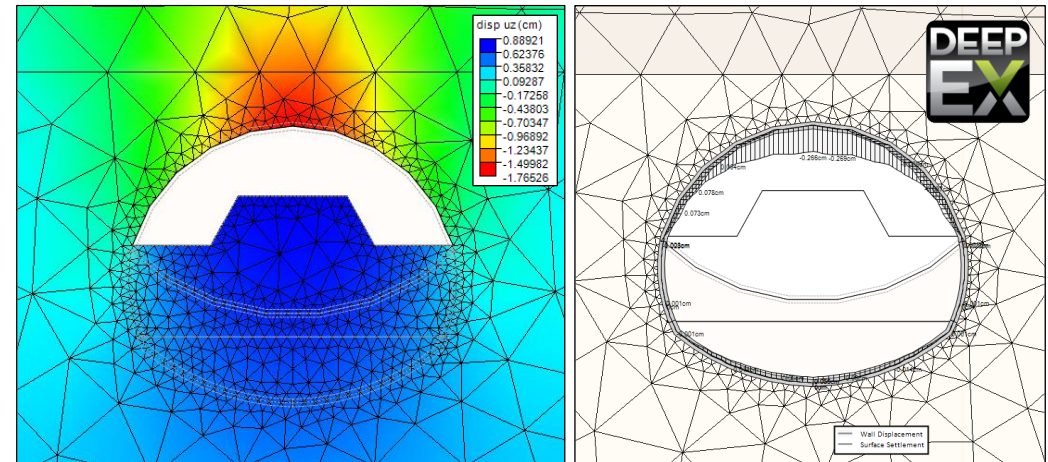

Introduction to the finite element method

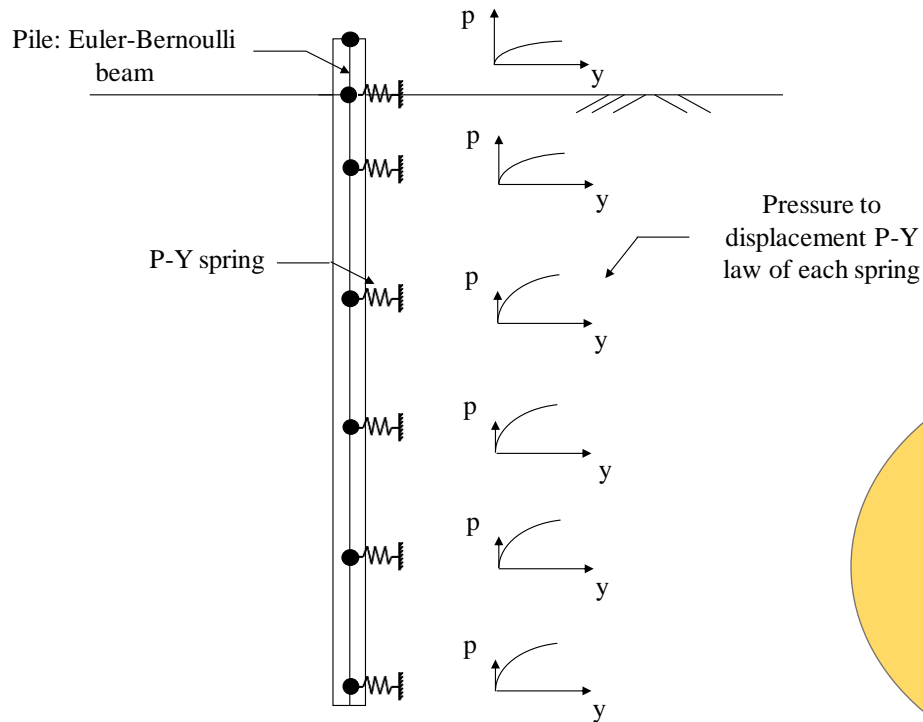

Winkler method

Numerical methods

Area of application/complexity varies from method to method!

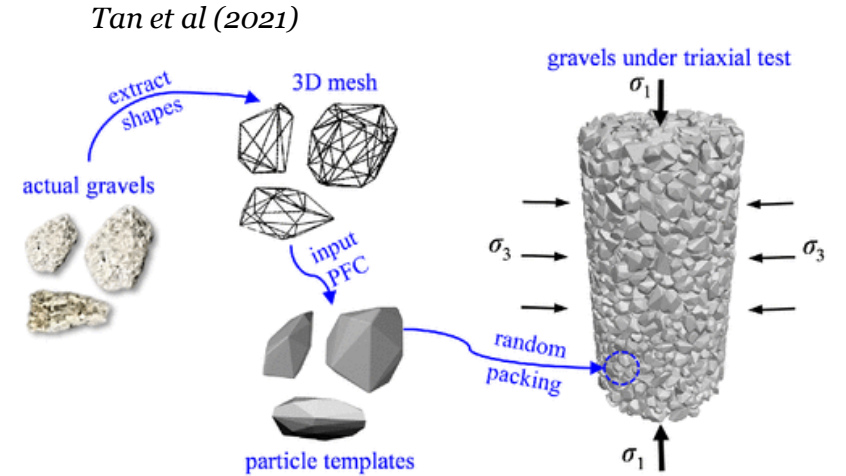

Discrete Element Method

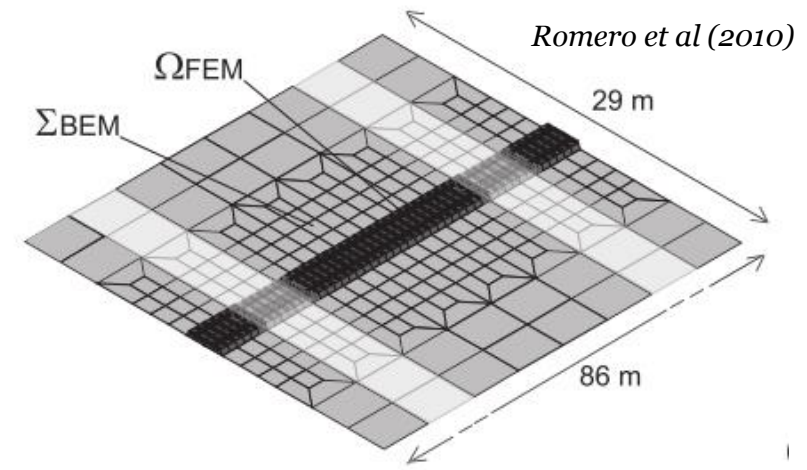

Boundary Element Method

Introduction to the finite element method

The Finite element method - a well-established numerical analysis method.

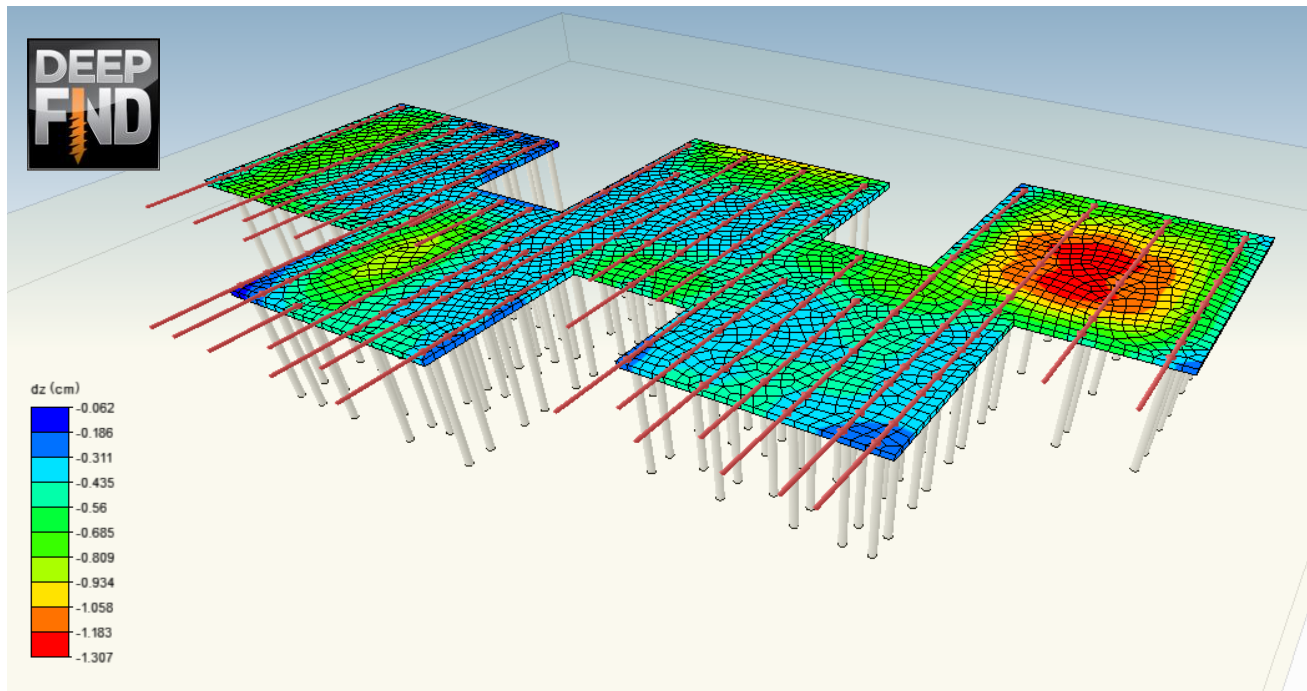

- Broad range of application
- complex geometry and boundary conditions
- simulation of the project as a whole

FEM Theoretical background



Physical structure

Modelling assumptions

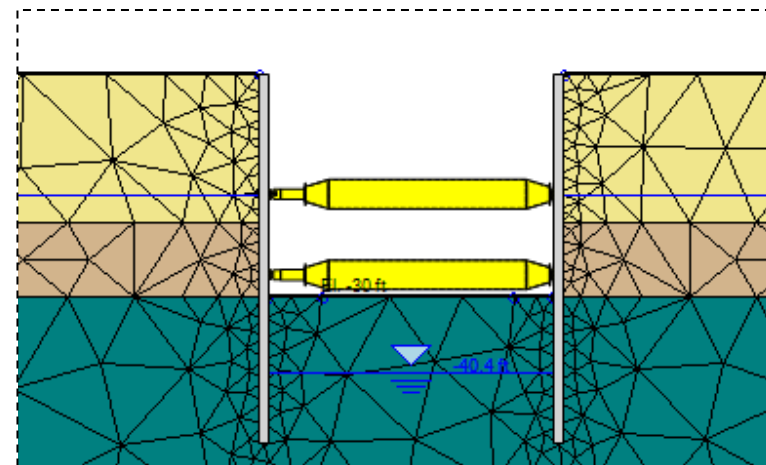
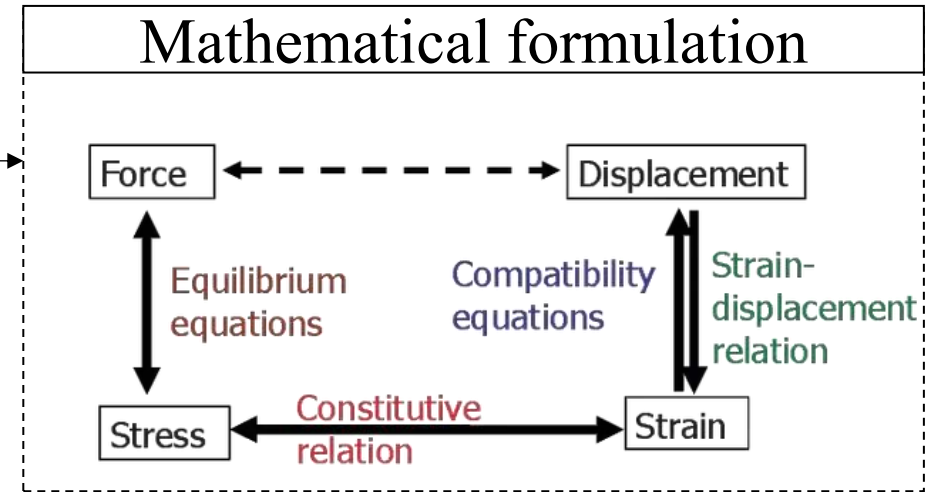

FEM numerical model

Discretization

FEM Theoretical background

(a) Equilibrium equations

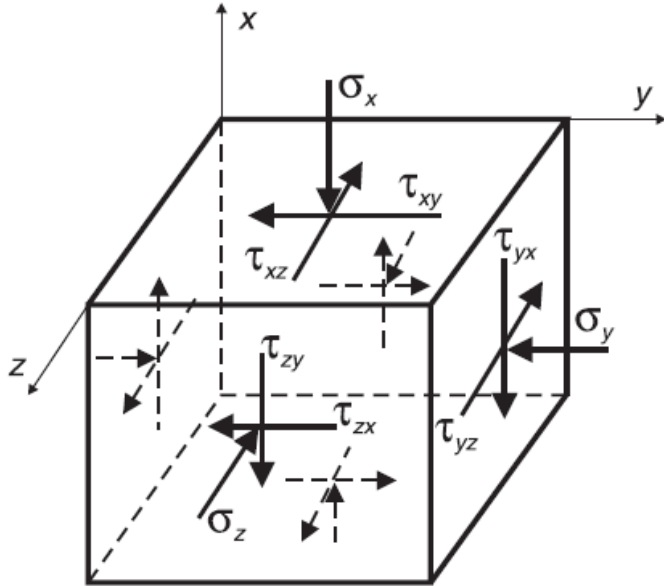

Stresses within the soil medium must satisfy equilibrium

Mathematical form: Cauchy momentum equation

External body forces

$$\text{div}_x \boldsymbol{\sigma} + \mathbf{b} = \rho \ddot{\mathbf{u}}$$

Divergence of stress tensor

Acceleration
(equal to zero for static analysis)

FEM Theoretical background

(b) Compatibility equations

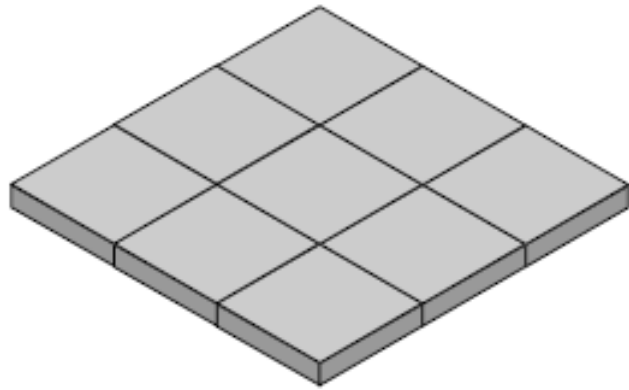

(a) Original

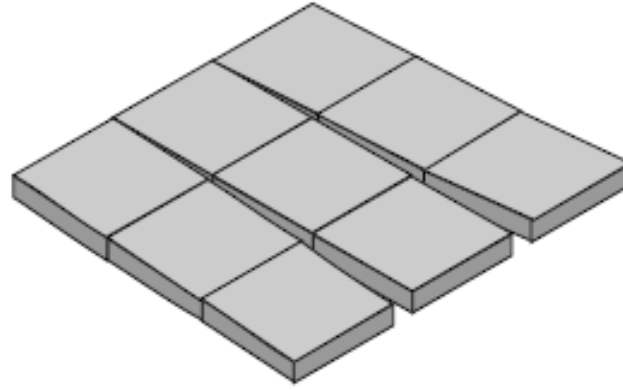

(b) Non-compatible

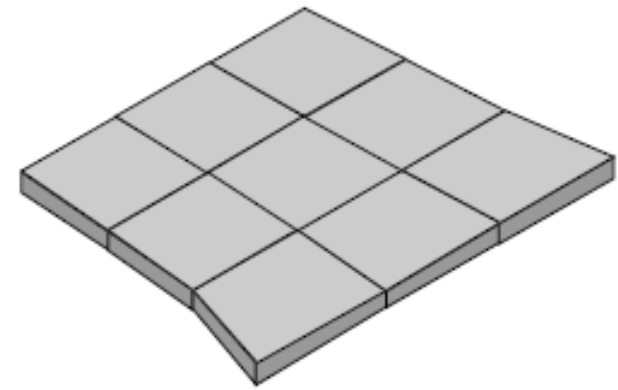

(c) Compatible

Strain to displacement relationship:

$$\begin{aligned}\epsilon_x &= -\frac{\partial u}{\partial x}; & \epsilon_y &= -\frac{\partial v}{\partial y}; & \epsilon_z &= -\frac{\partial w}{\partial z} \\ \gamma_{xy} &= -\frac{\partial v}{\partial x} - \frac{\partial u}{\partial y}; & \gamma_{yz} &= -\frac{\partial w}{\partial y} - \frac{\partial v}{\partial z}; & \gamma_{xz} &= -\frac{\partial w}{\partial x} - \frac{\partial u}{\partial z}\end{aligned}$$

FEM Theoretical background

(c) Constitutive law

Numerical simulations are part of everyday design tasks.

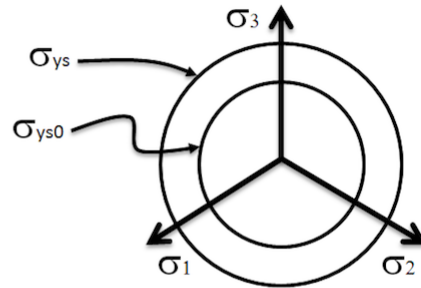
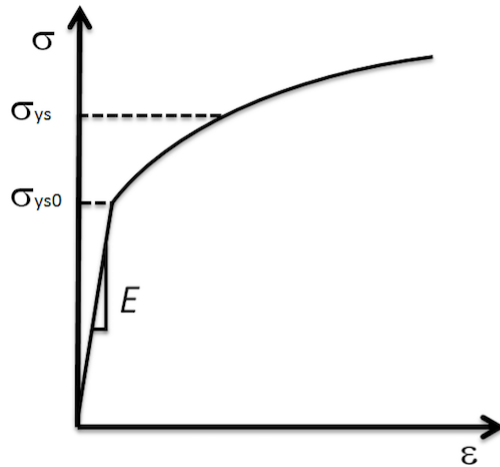

Yield surface in principal stress-space

Constitutive law

$$\Delta \boldsymbol{\sigma} = f_m(\Delta \boldsymbol{\varepsilon})$$

$$\begin{Bmatrix} \Delta \sigma_x \\ \Delta \sigma_y \\ \Delta \sigma_z \\ \Delta \tau_{xy} \\ \Delta \tau_{xz} \\ \Delta \tau_{zy} \end{Bmatrix}$$

Stress
increment

$$\begin{Bmatrix} \Delta \varepsilon_x \\ \Delta \varepsilon_y \\ \Delta \varepsilon_z \\ \Delta \gamma_{xy} \\ \Delta \gamma_{xz} \\ \Delta \gamma_{zy} \end{Bmatrix}$$

Strain
Increment

FEM Theoretical background

(e) Boundary Conditions and model geometry

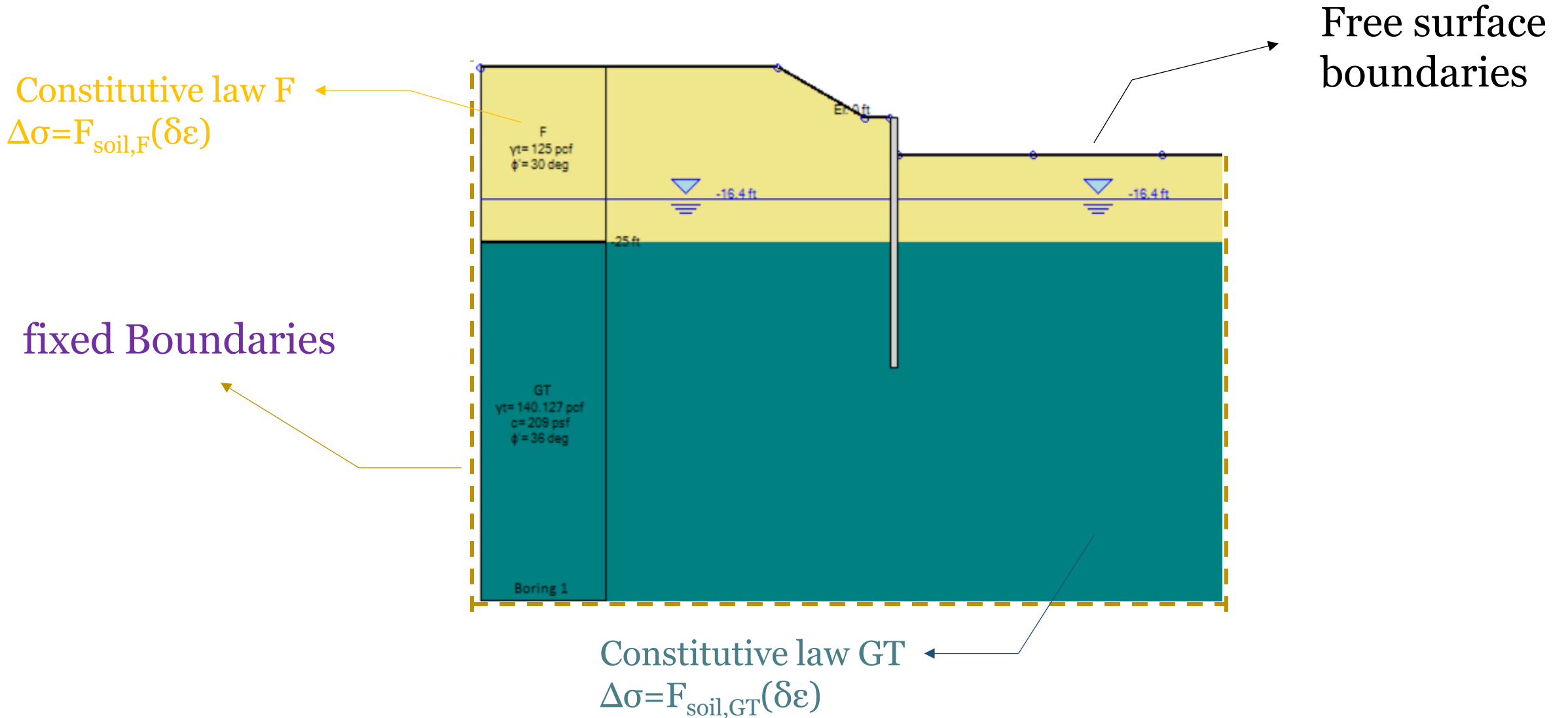

FEM Theoretical background

Reformulating the PDE system to an easily solvable system of algebraic equations!!

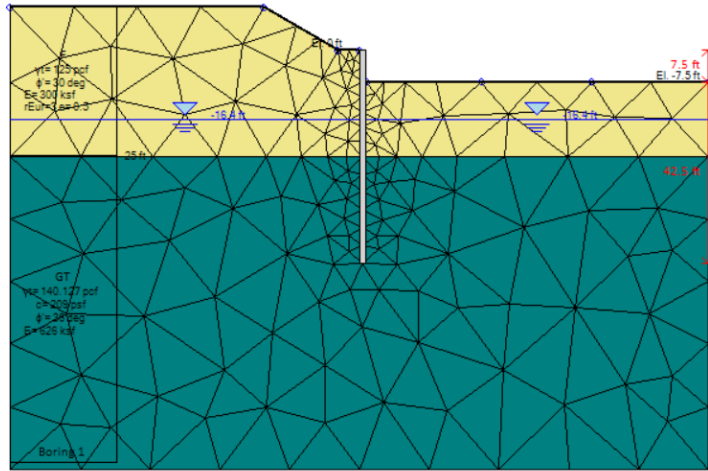

Step 1: Discretize the continuum

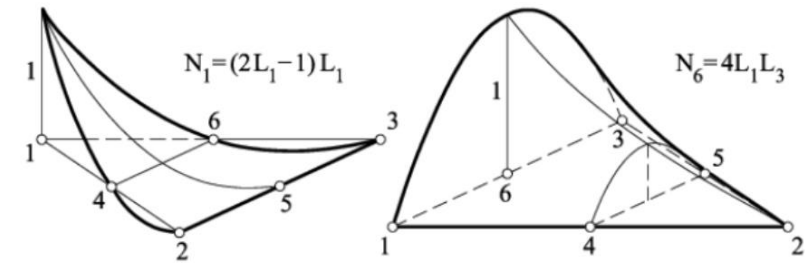

Step 2: Select interpolation functions

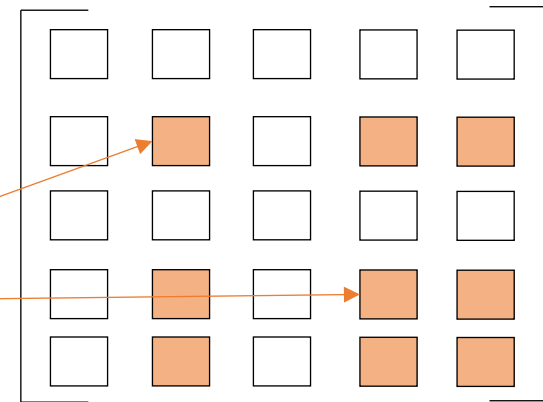
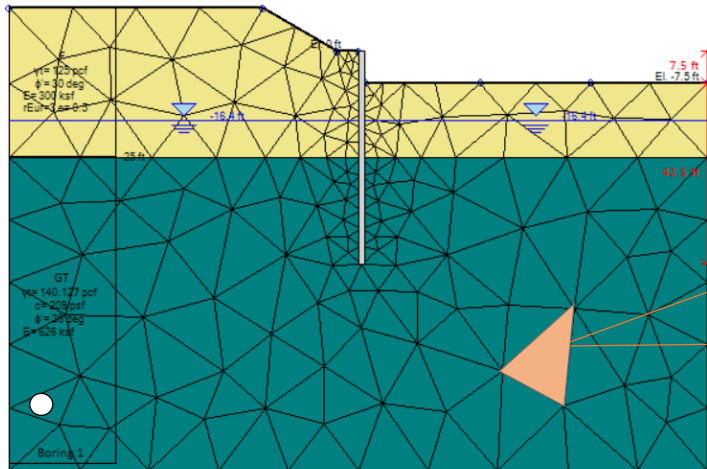

Step 3: Assemble the global equation system

FEM Theoretical background

Structural components **can** be simulated with continuum elements:

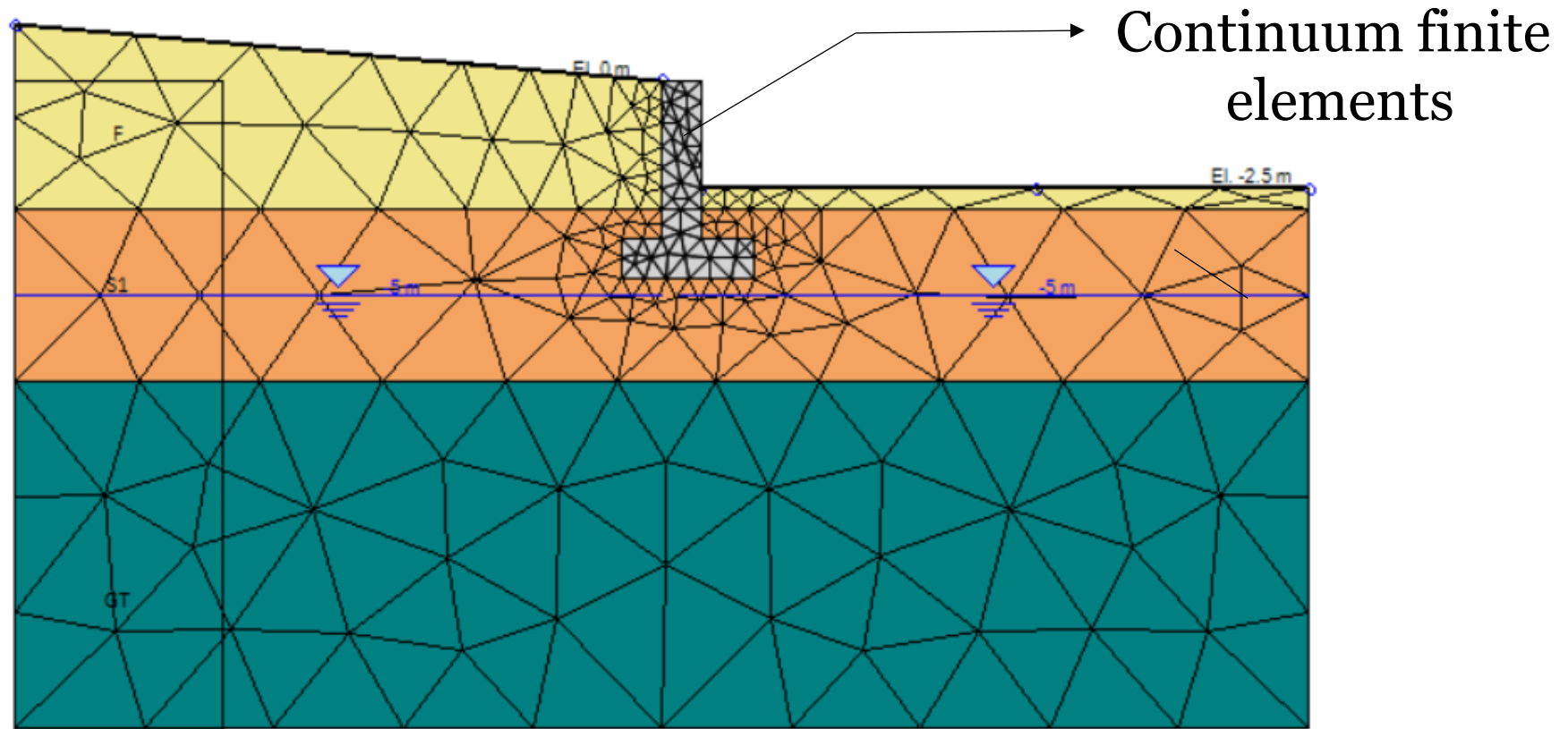

FEM Theoretical background

Common use of additional **special** finite elements.

Advantages:

- inelastic behaviour
- computationally faster
- stress directly in member level

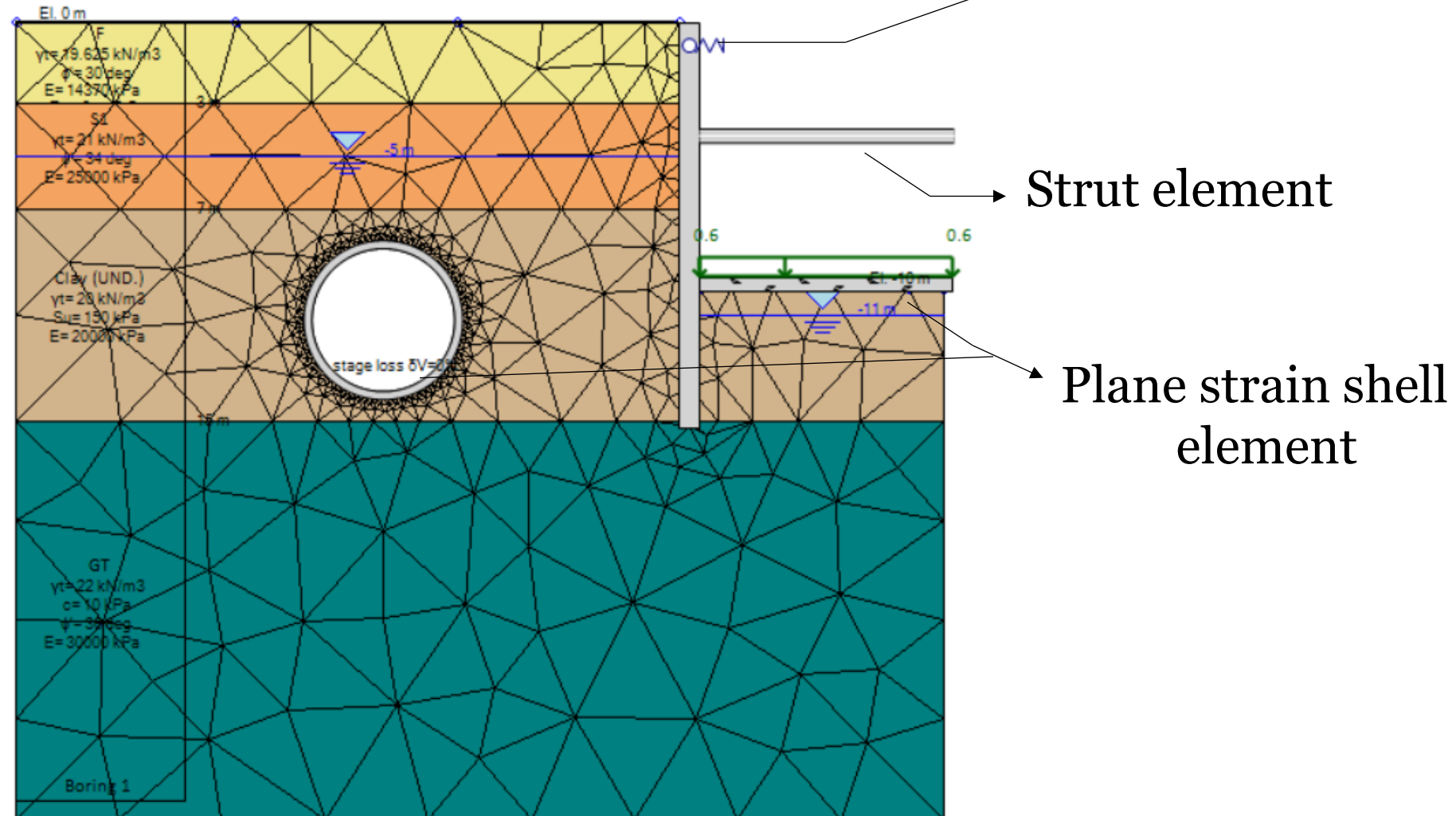

FEM Theoretical background

What results can you obtain from FEM?

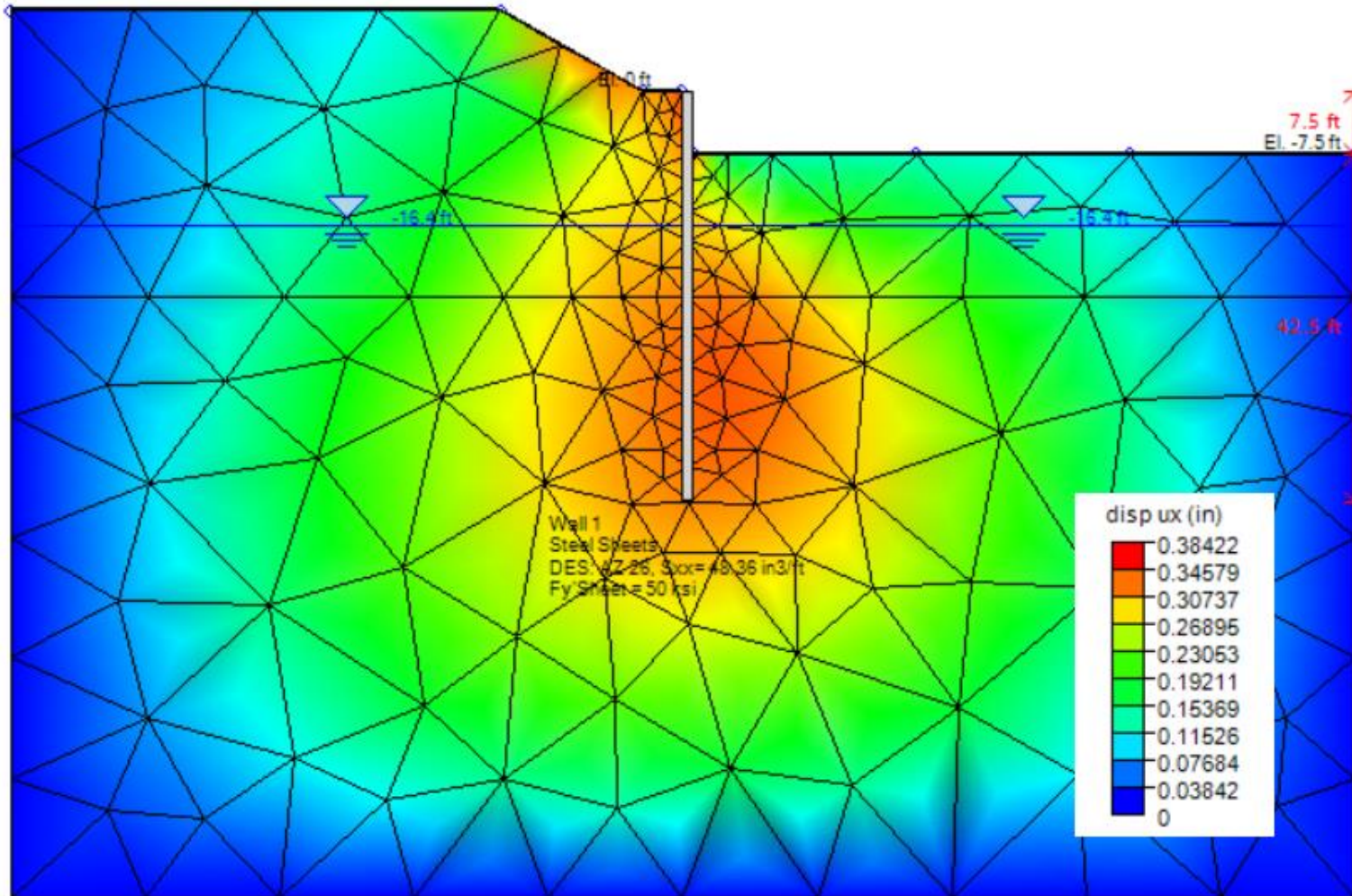

- Displacement and stress nodal properties
- displacement and stresses in any element location (interpolation)
- failure states!

FEM Theoretical background

Plane strain conditions:

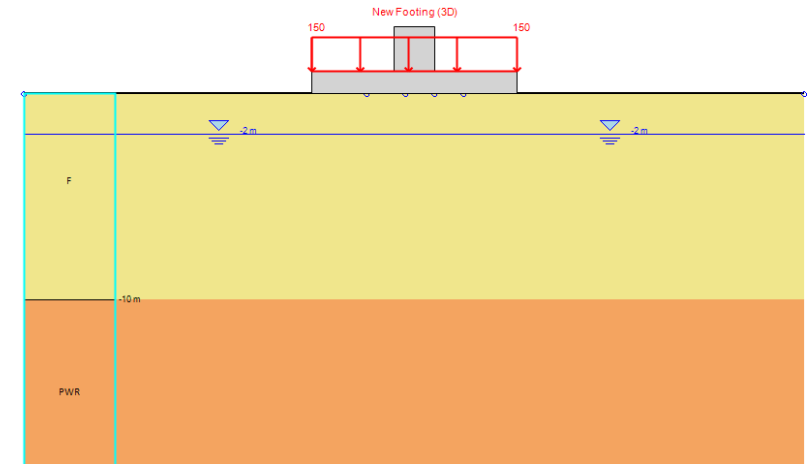
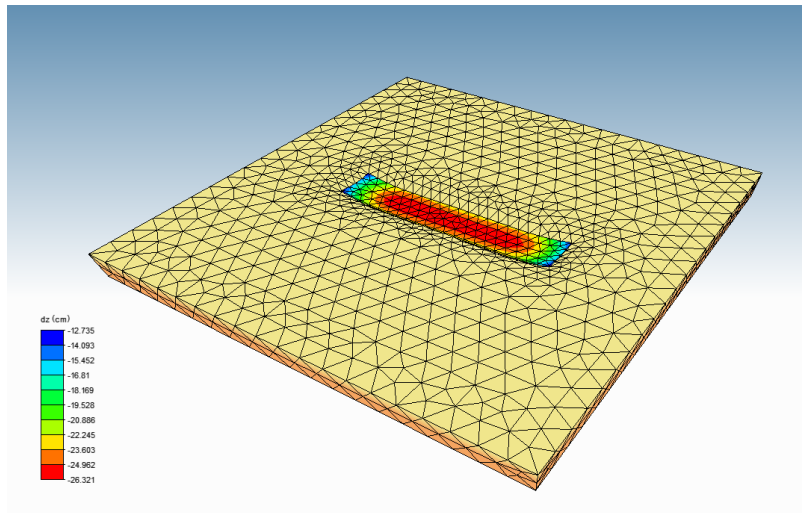

- Valid for systems with one dimension much larger than the others.
- Assumes zero strain on larger dimension
- stress on larger dimension is non-zero.

FEM Theoretical background

System conditions on floodwall project:

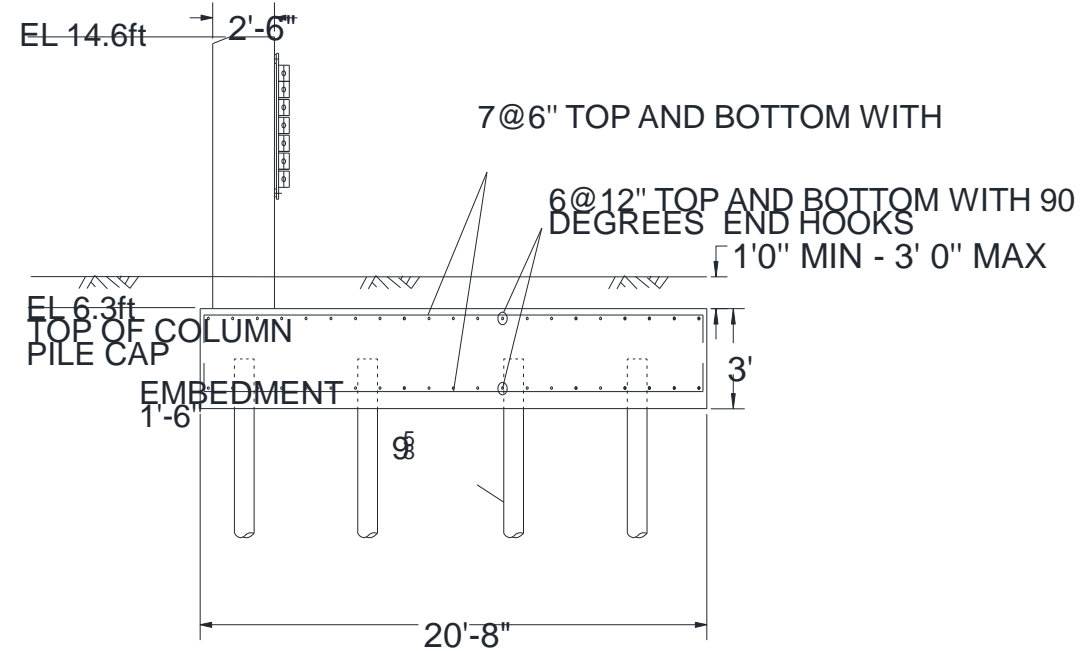
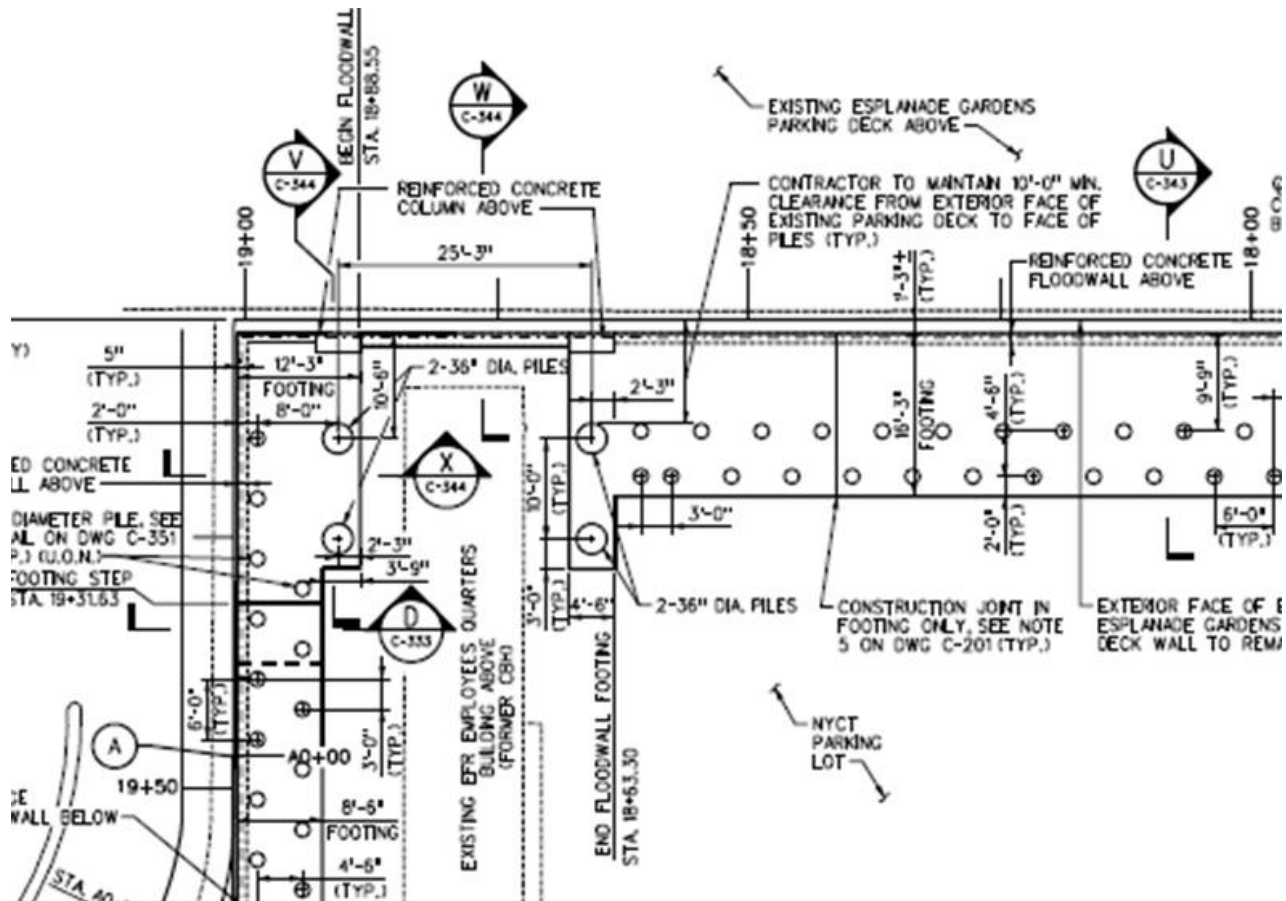

FEM Theoretical background

Plane strain conditions

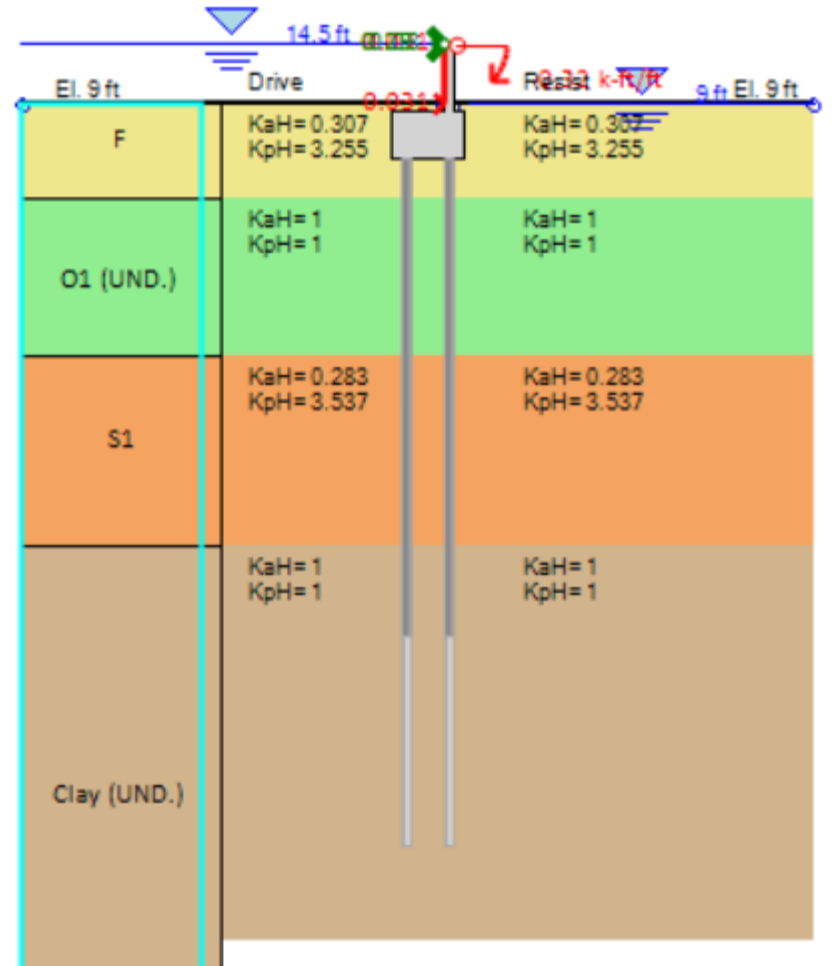
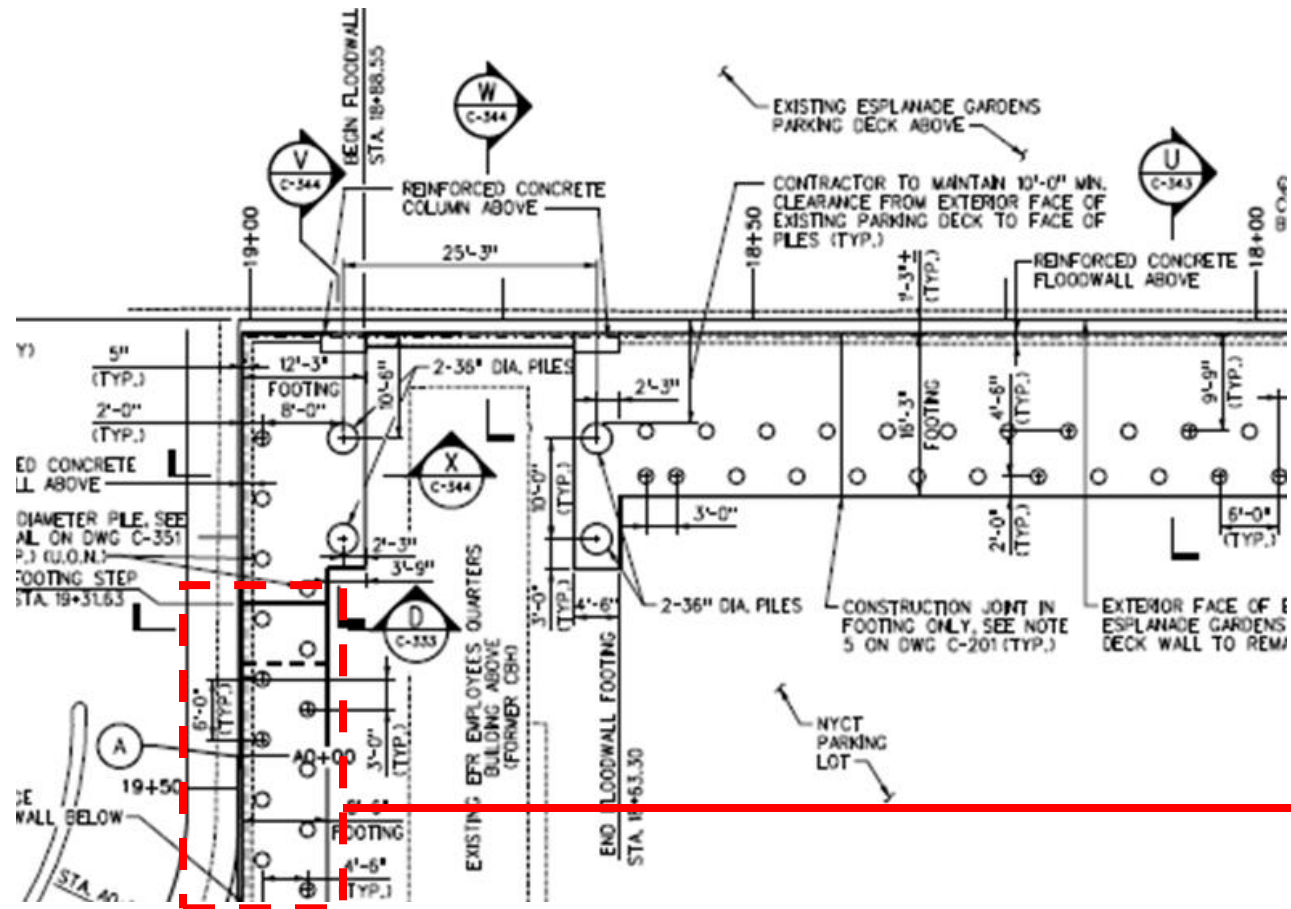

FEM Theoretical background

3D conditions

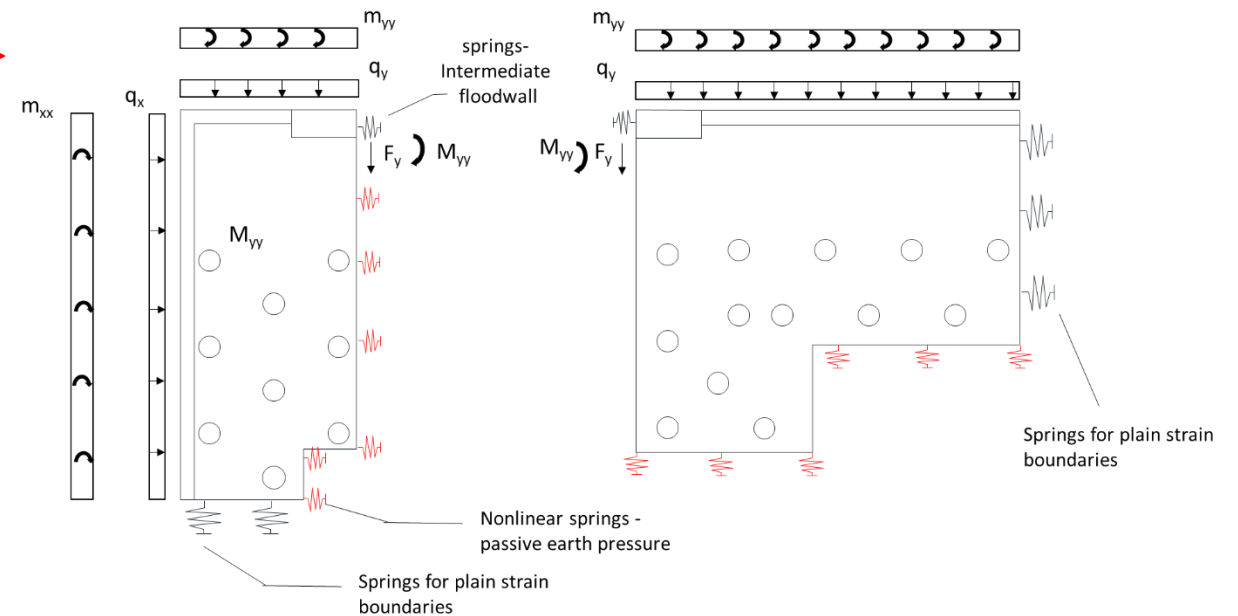
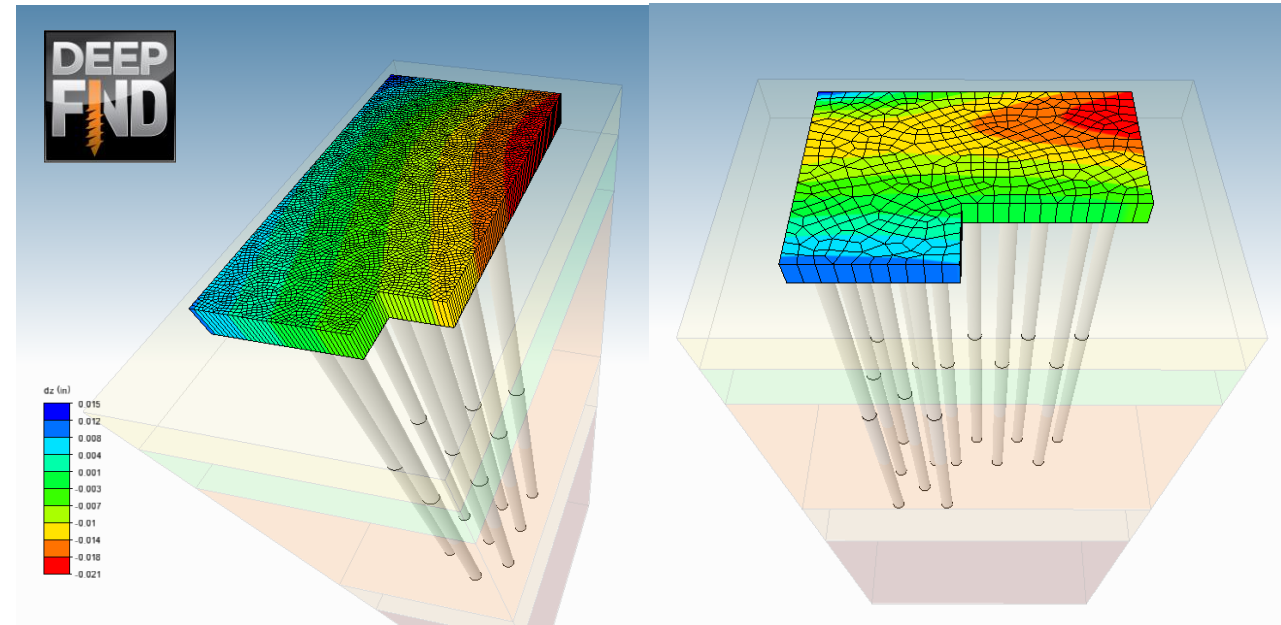
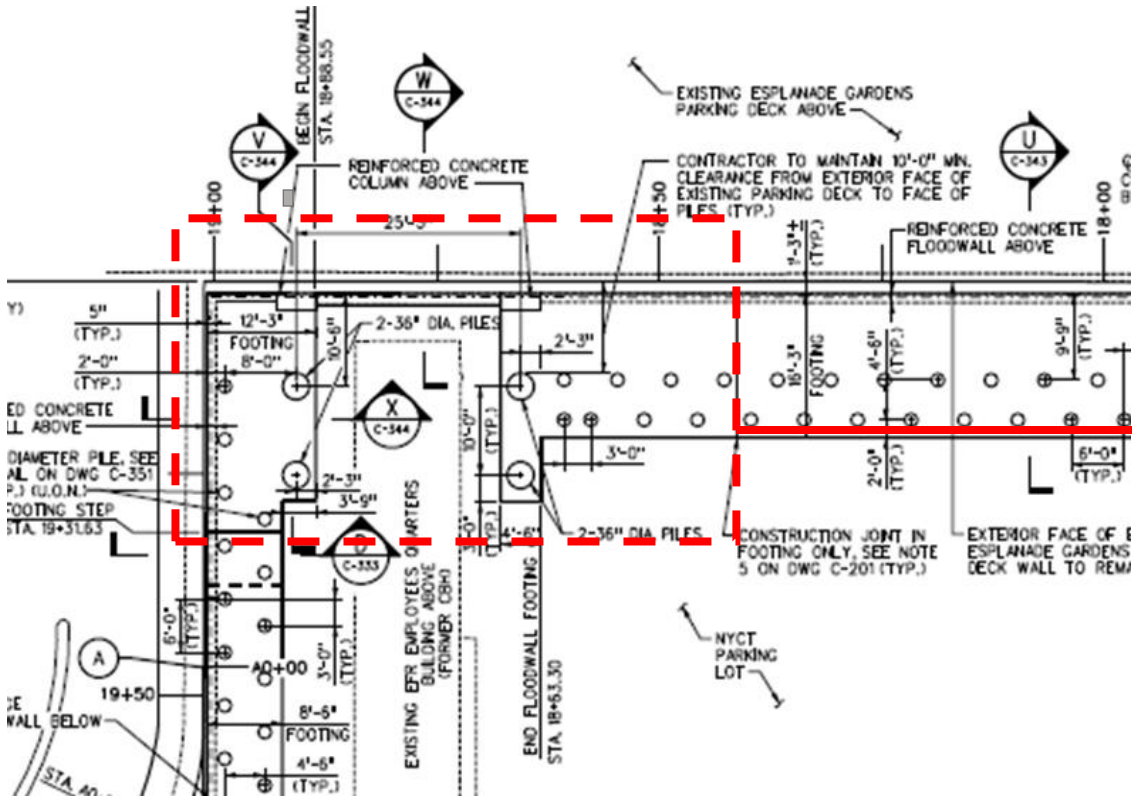

Good practice in FEM model construction

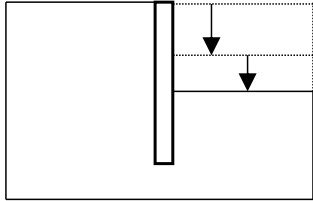

Staging

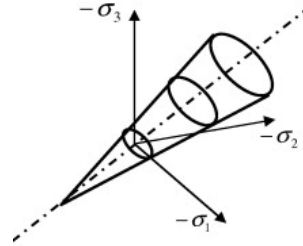

Soil constitutive laws

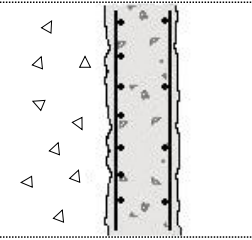

soil-structure
interface

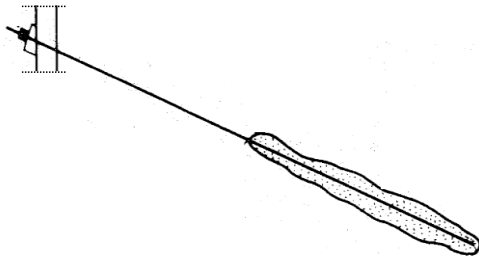

structural components

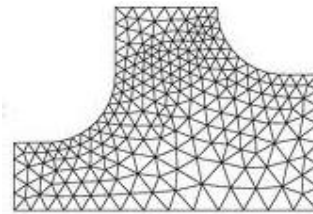

Meshing

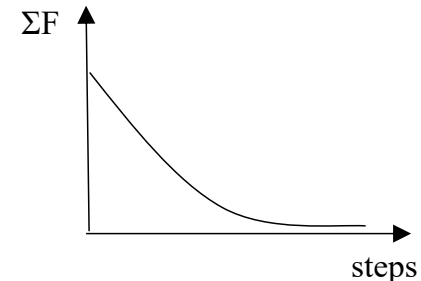

Analysis options

Good practice in FEM model construction

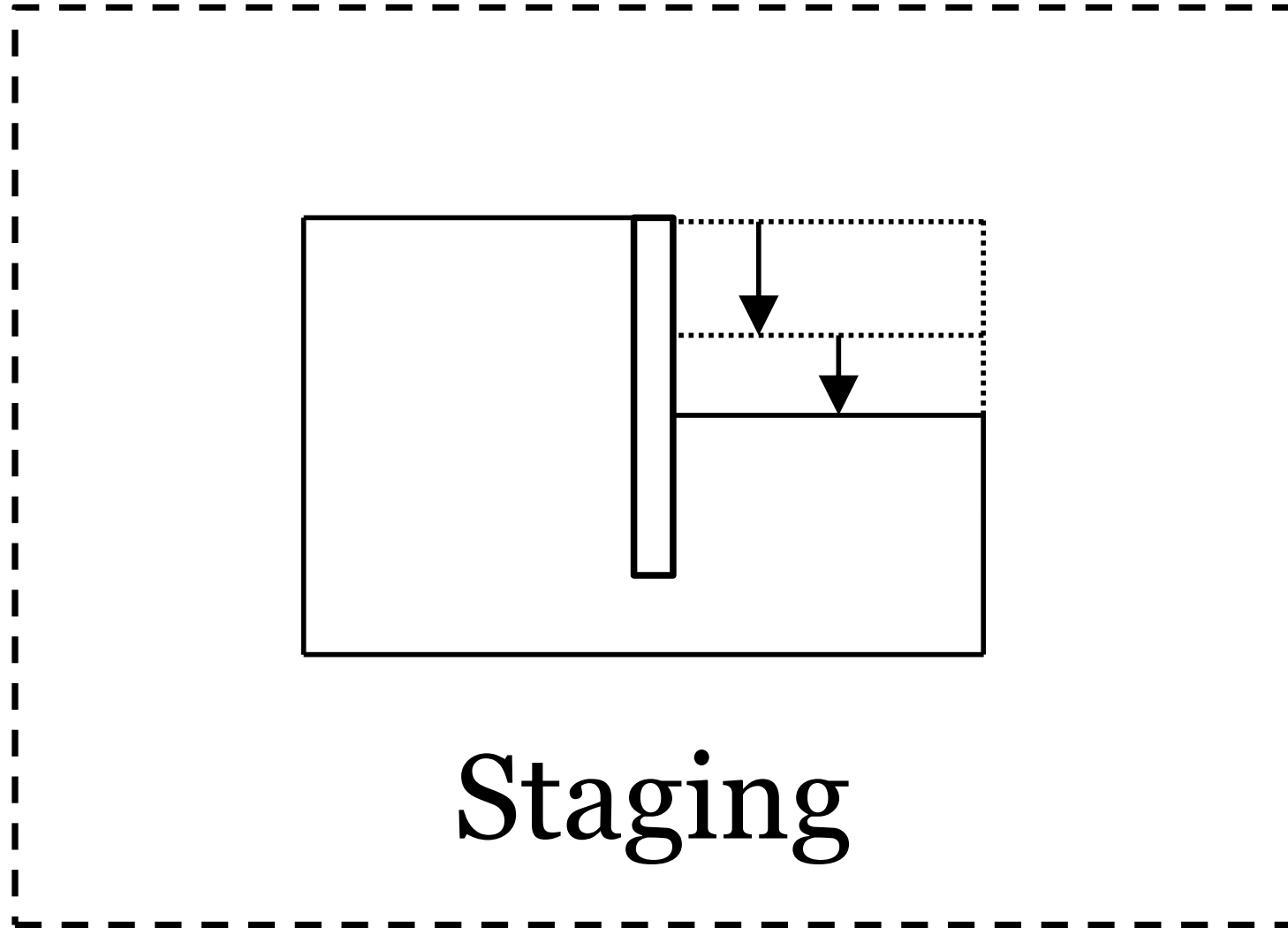

Staging sequence

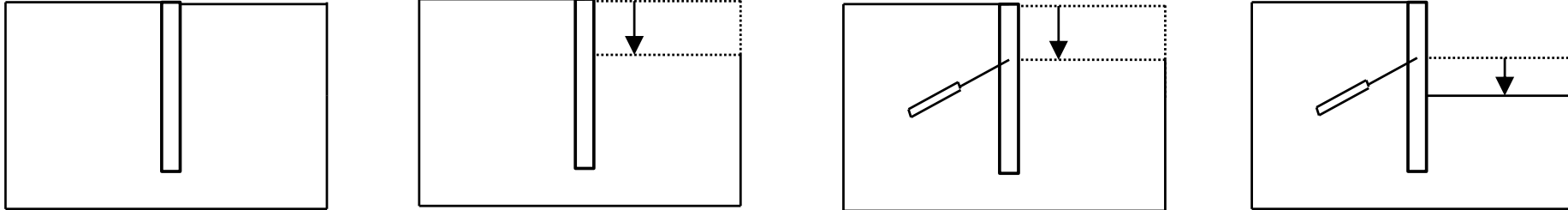

Why is staging necessary?

- Accurate representation of construction process
- smooth convergence for the FEM model

Staging sequence

Initial stage in FEM analysis : Greenfield conditions.

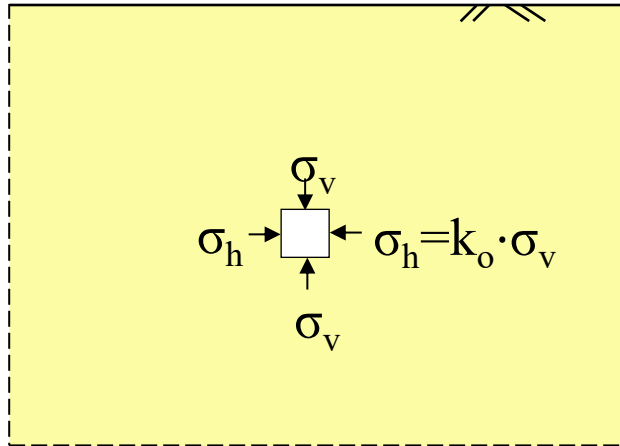

Imposed stress field
(k_o)

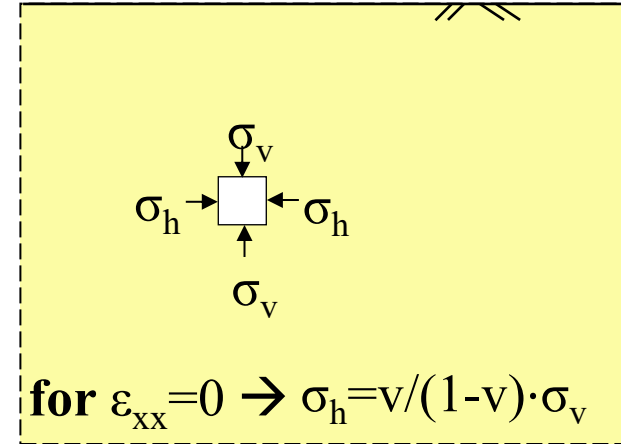

Gravity Analysis

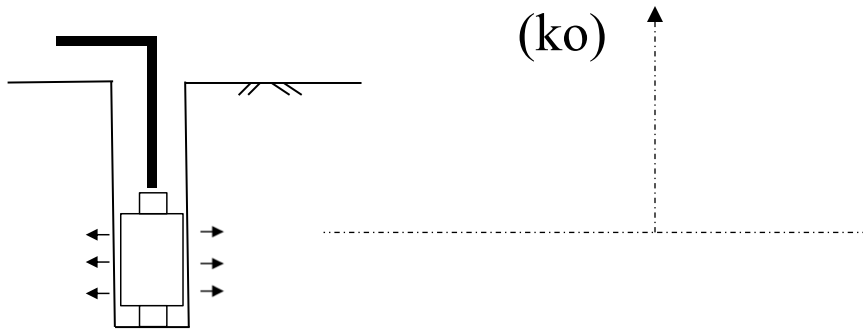

On site measurement
(pressuremeter test)

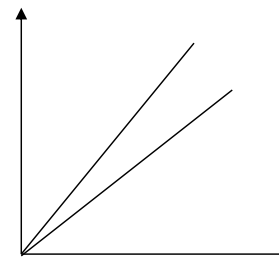

Corelation formulas
(k_o to OCR etc)

Model Staging Sequence

Imposed stress field: equilibrium **not** always satisfied!!

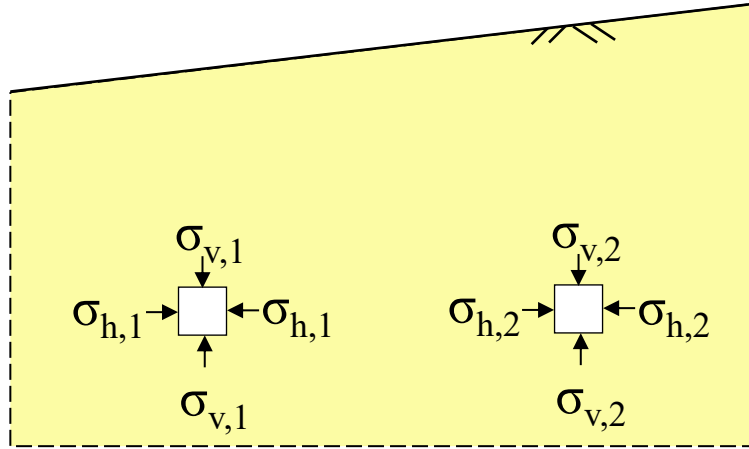

(a) Inclined surface

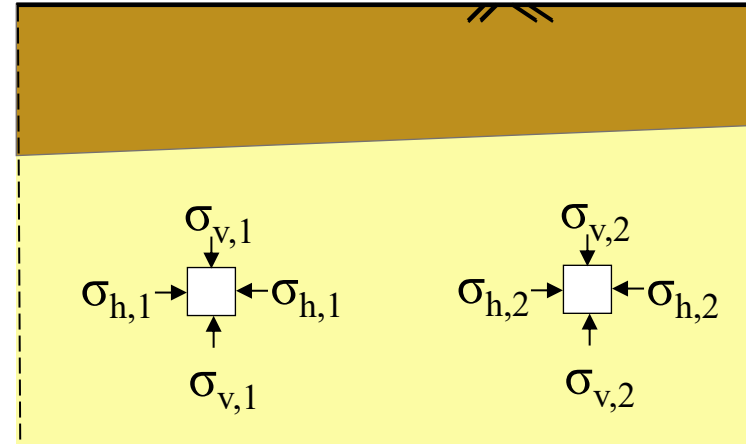

(b) Inclined layers

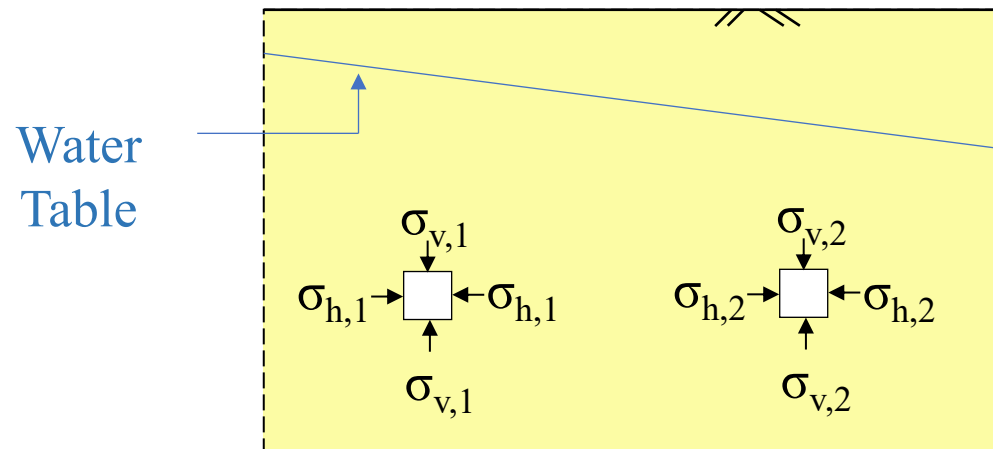

(c) Inclined water table

Model Staging Sequence

Rule of thumb: separate stage for each action.

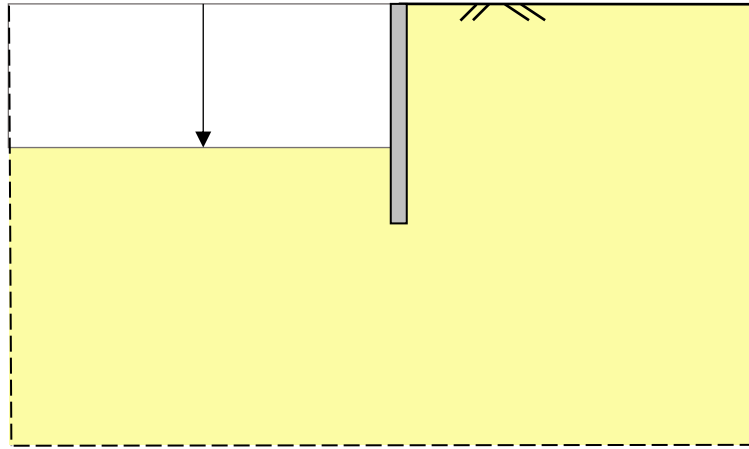

(a)Excavation

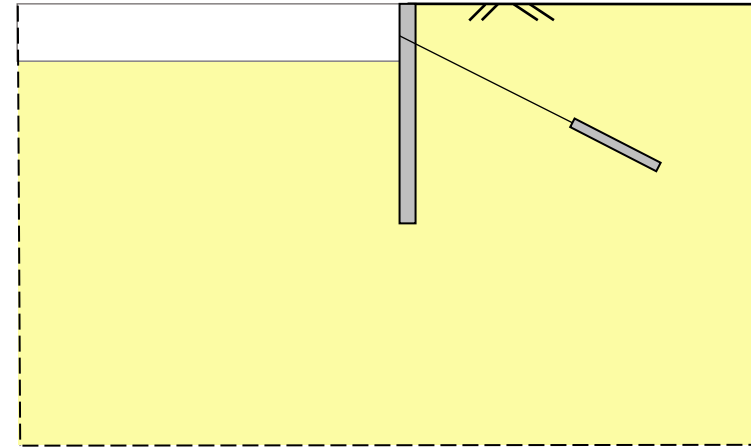

(b)Support installation

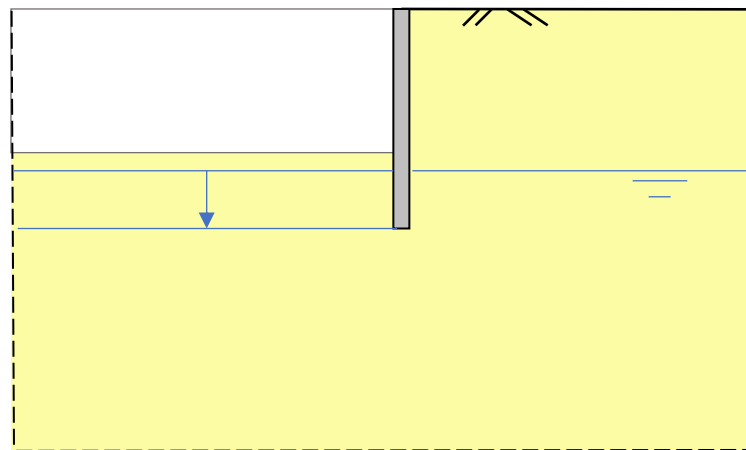

(c)Dewatering

Model Staging Sequence



Example 1: Staging in cut and cover tunnel construction.

Model Staging Sequence

Example 1: Staging in cut and cover tunnel.

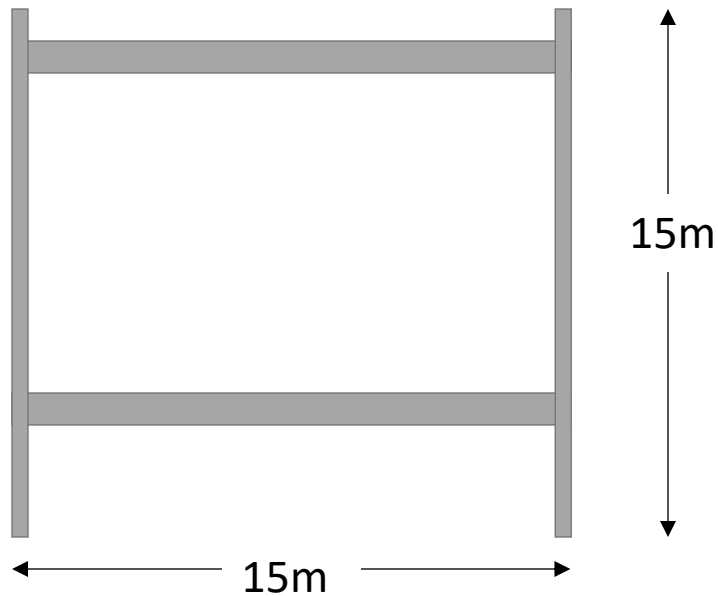

Bottom up construction:

Stage 0 : greenfield conditions

Stage 1: installation of walls (Diaphragm 0.6m)

Stage 2: excavation at depth **-3.5 m**

Stage 3: add a temporary prop at depth -3m

stage 4: excavation at depth -8 m/ dewatering at -9m

Stage 5: add a temporary prop at depth -7m

stage 6: excavation at depth -12 m/ dewatering at -14.5m

stage 7: construct floor slab at -12 m (H=20cm)

stage 8: construct top slab at -1 m (H=20cm)

Stage 9 : remove temporary pros

Model Staging Sequence

Example 1: Staging in cut and cover tunnel.

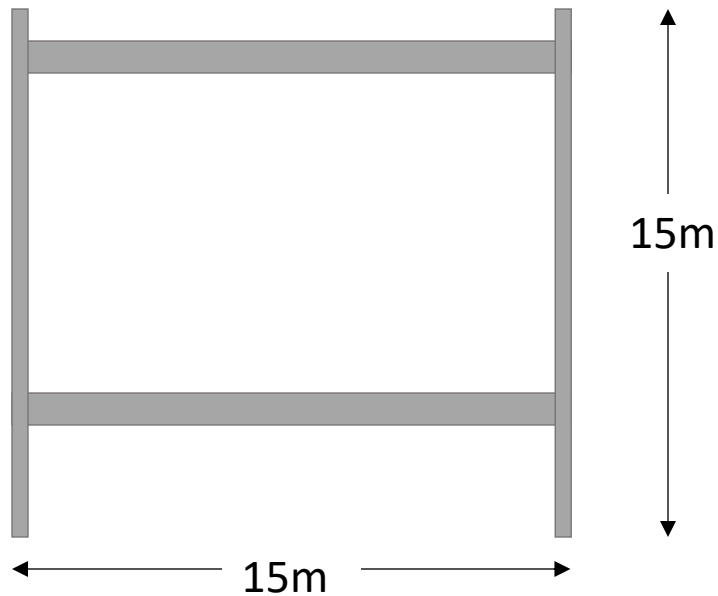

Top Down construction:

Stage 0 : greenfield conditions

Stage 1: installation of walls

Stage 2: excavation at depth -1 m

Stage 3: construct top slab at -1 m

stage 4: excavation at depth -8 m /
dewatering at -9m

Stage 5: add a temporary prop at depth -7m

stage 6: excavation at depth -12 m
/dewatering at -14.5m

stage 7: construct floor slab at -12 m

Stage 8 : remove temporary pros

Model Staging Sequence

Presence of adjacent structures can **modify** state of stress!

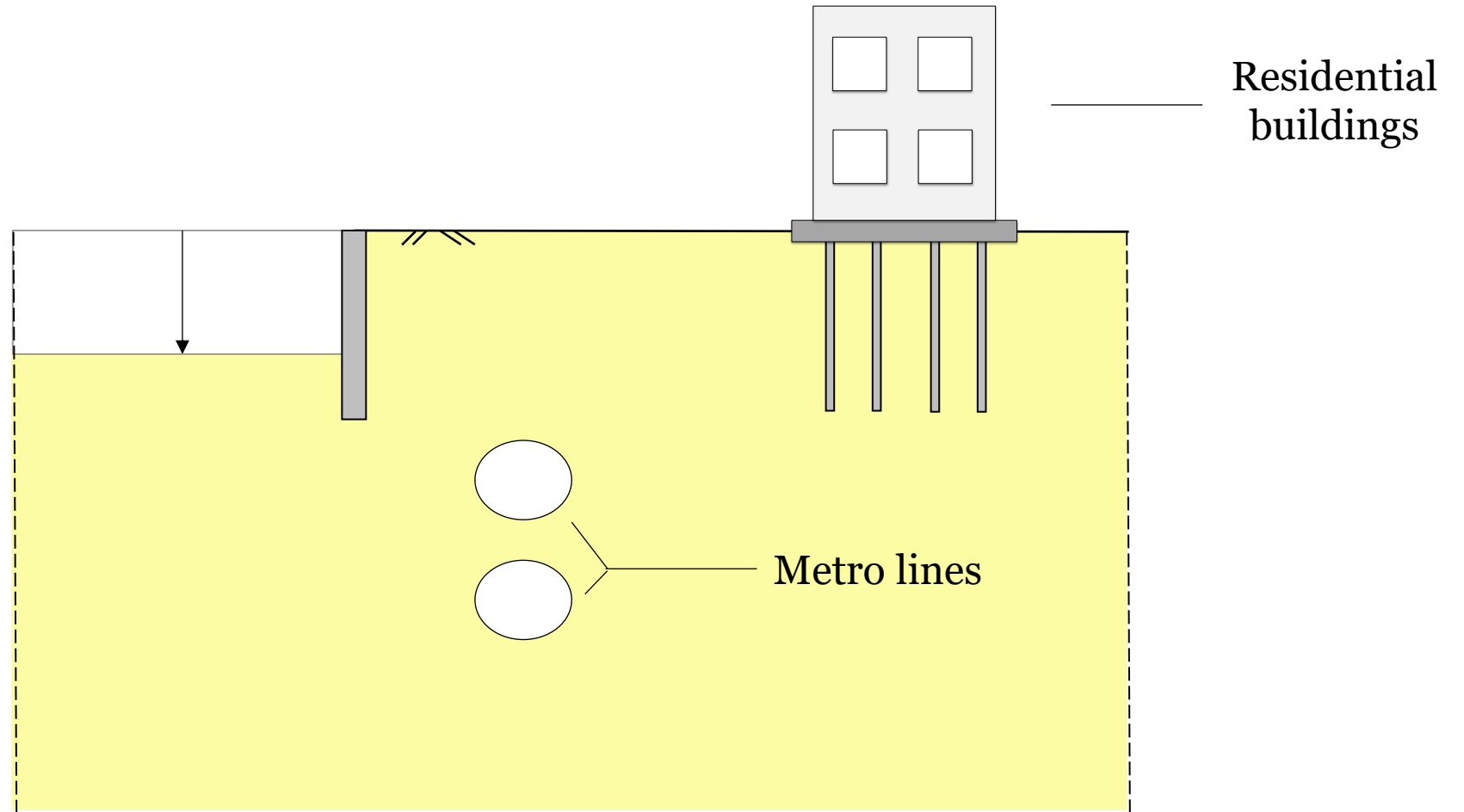

Model Staging Sequence

preexisting Shanghai
Metro tunnels

Cement – soil mixed piles

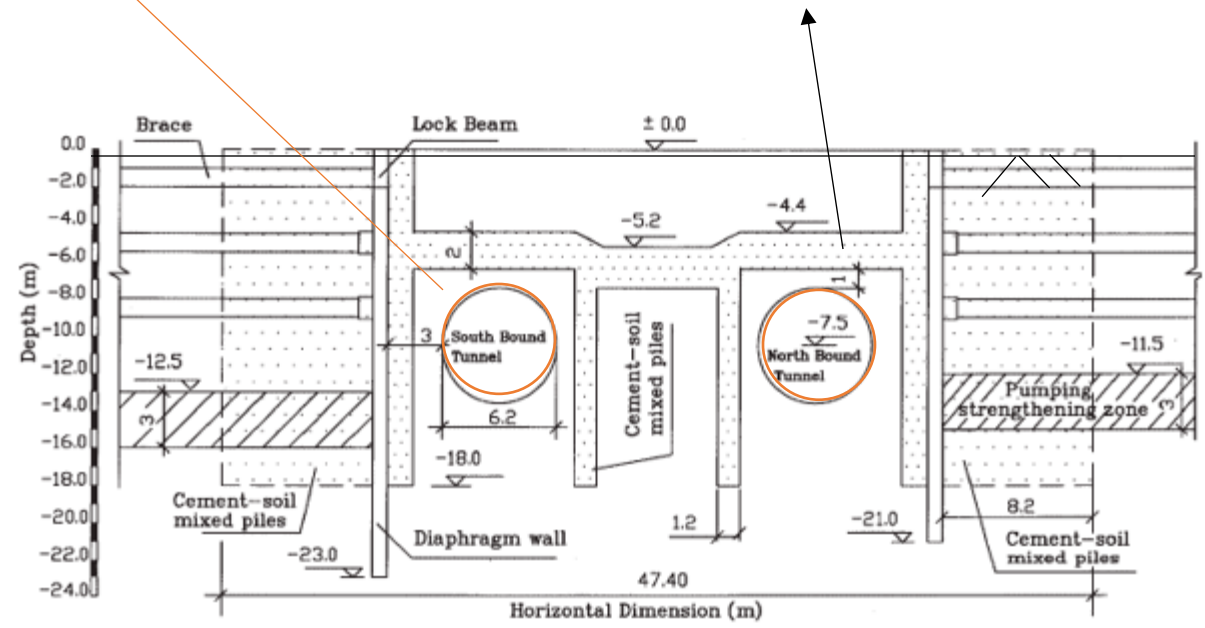
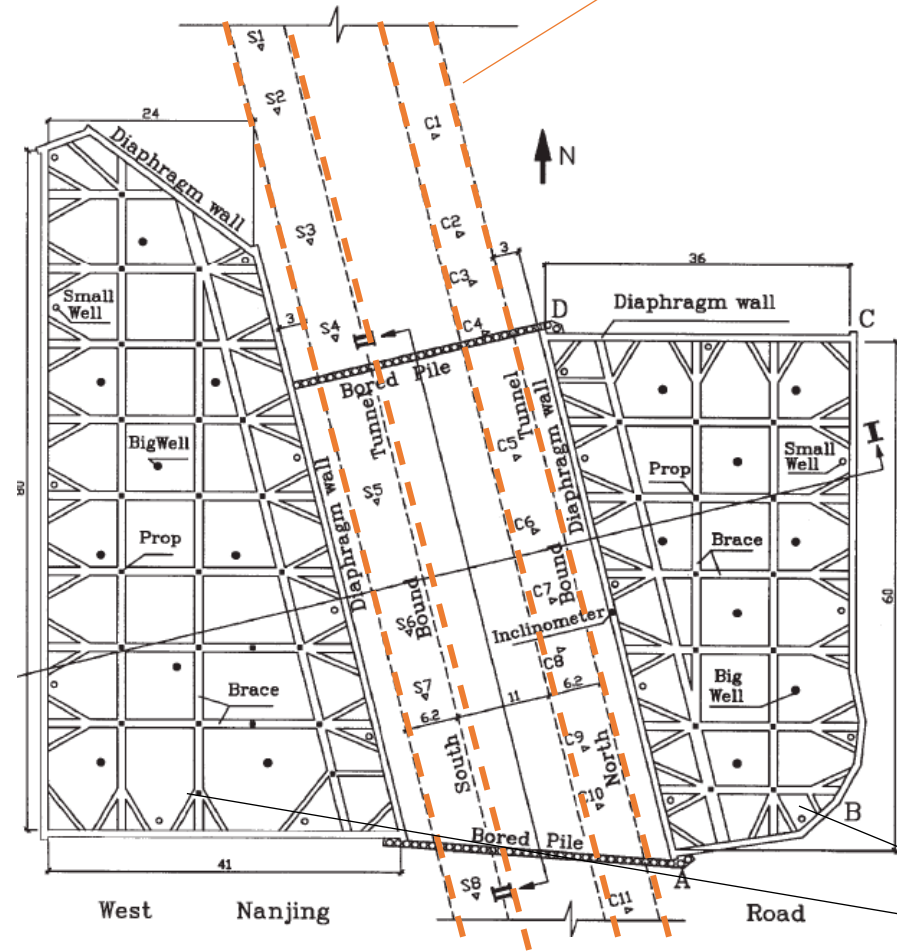

excavations for world Commercial
City Complex

Good practice in FEM model construction

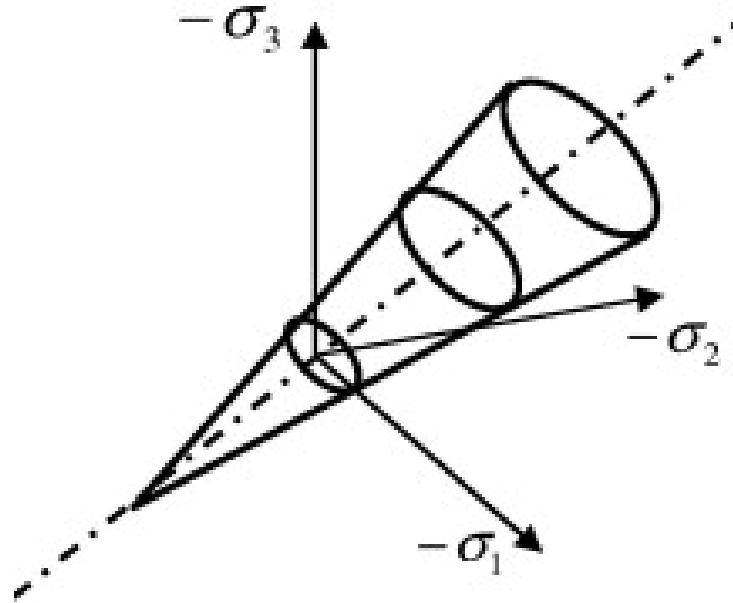

Soil constitutive laws

Soil Constitutive laws

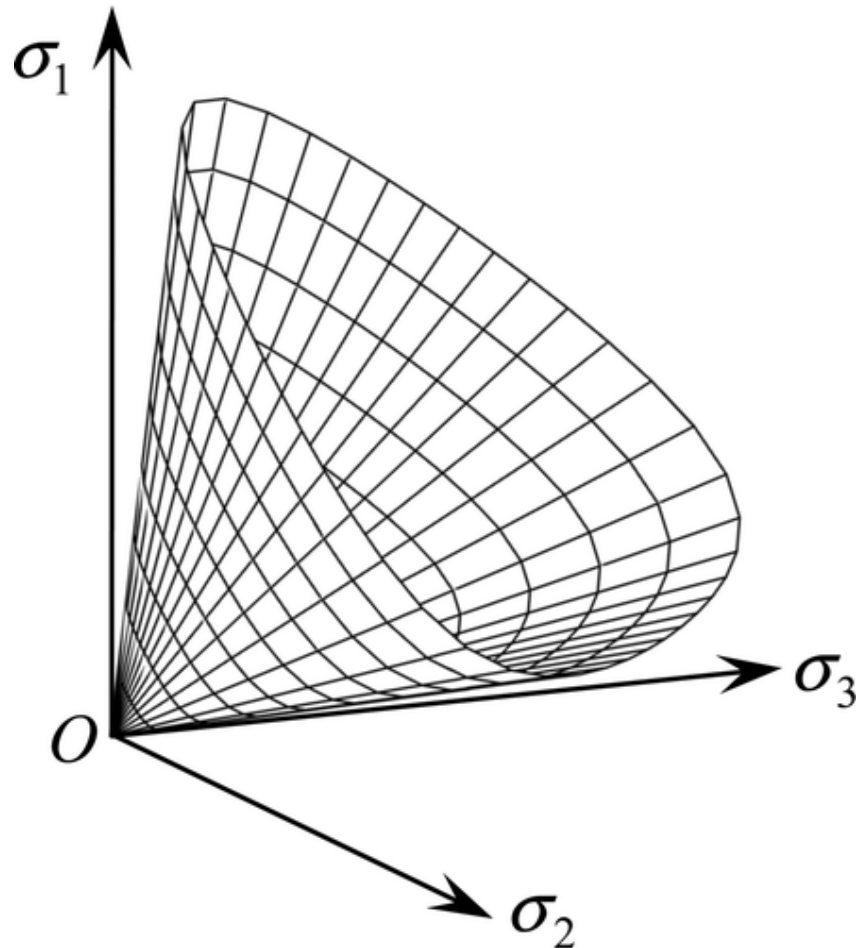

Selection of soil constitutive law based on:

- Specific problem in question
- Available soil data

Constitutive law comprised of:

- Yield function
- plastic potential function
- hardening/softening rules

Soil Constitutive laws

Model components: (a) Elastic behavior

$$\begin{bmatrix} \sigma_{11} \\ \sigma_{22} \\ \sigma_{33} \\ \sigma_{23} \\ \sigma_{13} \\ \sigma_{12} \end{bmatrix} = \frac{E}{(1+\nu)(1-2\nu)} \begin{bmatrix} 1-\nu & \nu & \nu & 0 & 0 & 0 \\ \nu & 1-\nu & \nu & 0 & 0 & 0 \\ \nu & \nu & 1-\nu & 0 & 0 & 0 \\ 0 & 0 & 0 & \frac{1-2\nu}{2} & 0 & 0 \\ 0 & 0 & 0 & 0 & \frac{1-2\nu}{2} & 0 \\ 0 & 0 & 0 & 0 & 0 & \frac{1-2\nu}{2} \end{bmatrix} \begin{bmatrix} \varepsilon_{11} \\ \varepsilon_{22} \\ \varepsilon_{33} \\ 2\varepsilon_{23} \\ 2\varepsilon_{13} \\ 2\varepsilon_{12} \end{bmatrix}$$

Elastic parameters **linearly mapping** the strain tensor to the stress tensor.

Soil Constitutive laws

Model Ingredients: (a) Yield Function

- separates purely elastic from elastoplastic behaviour.
- Function of stresses or stress invariants and hardening parameters

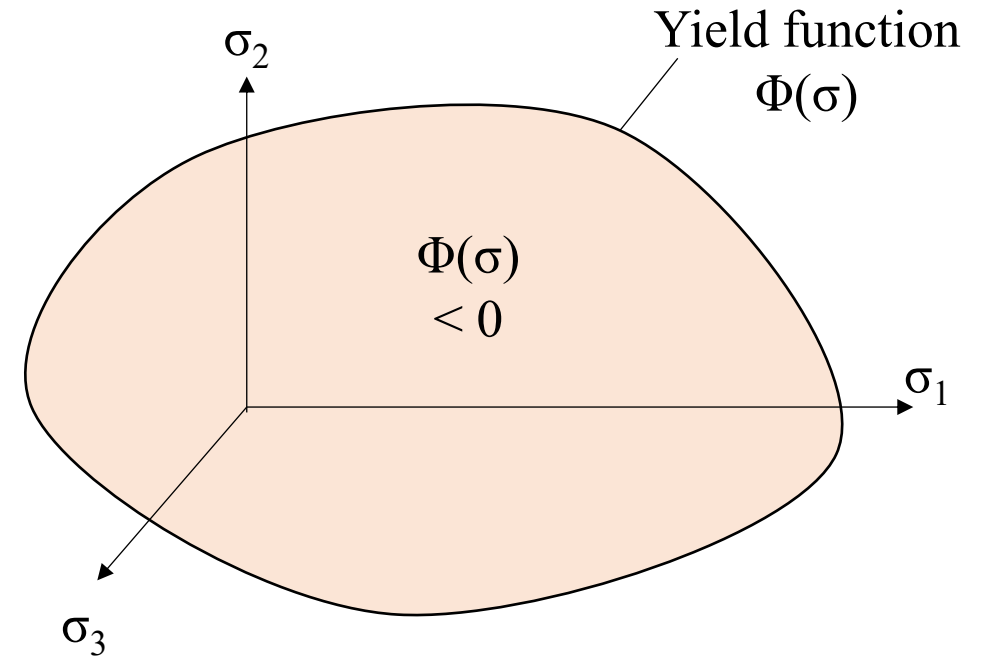

Soil Constitutive laws

Model Ingredients: (b) plastic potential function

- specifying the direction of strains post yielding
- govern dilatancy effects

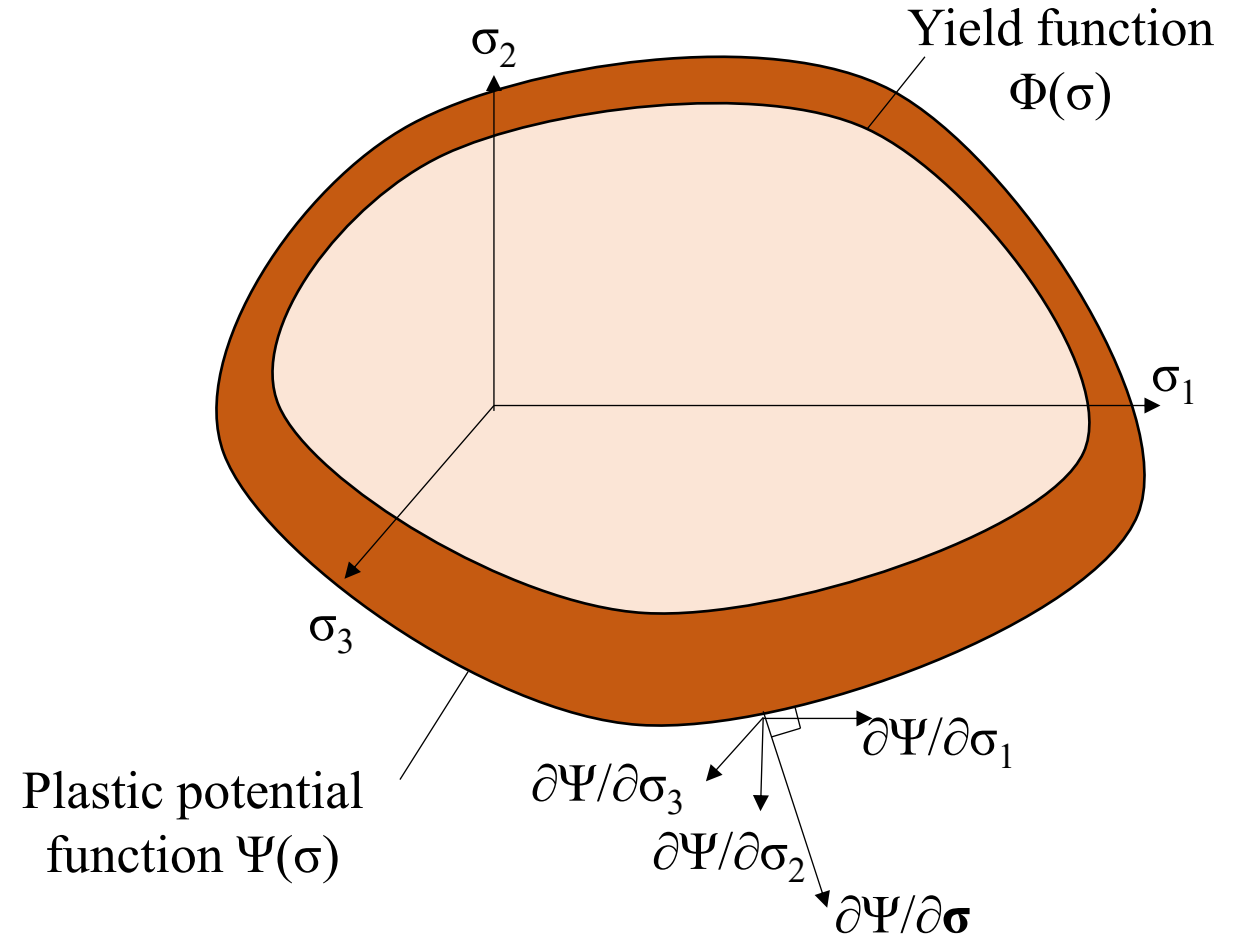

Soil Constitutive laws

Model Ingredients: (c) Hardening/Softening rules

- Post failure hardening or softening behavior
- capture pre-failure inelastic behaviour

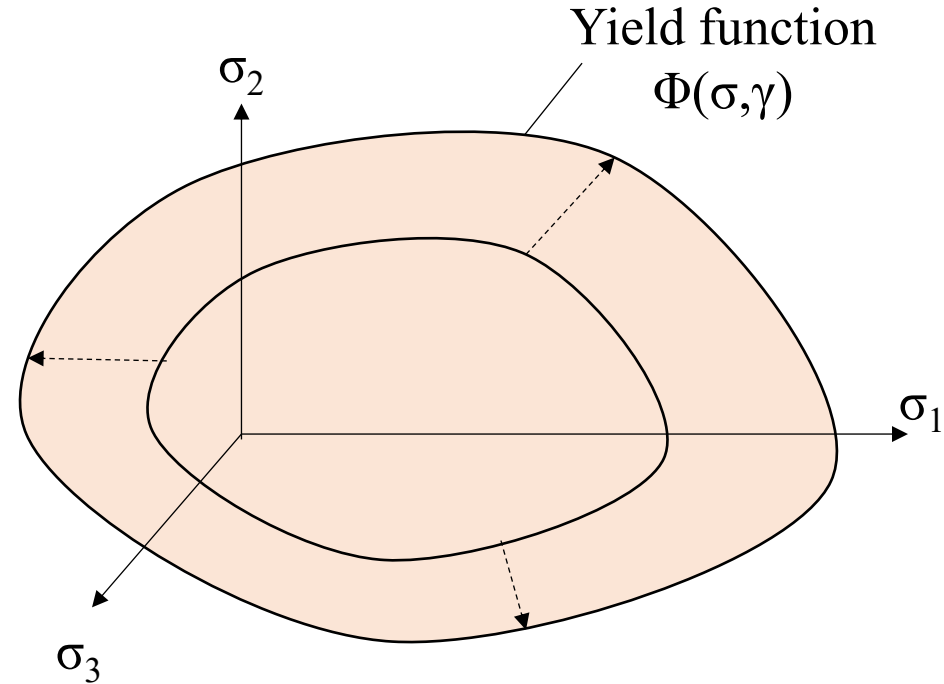

Soil Constitutive laws

Mohr Coulomb:

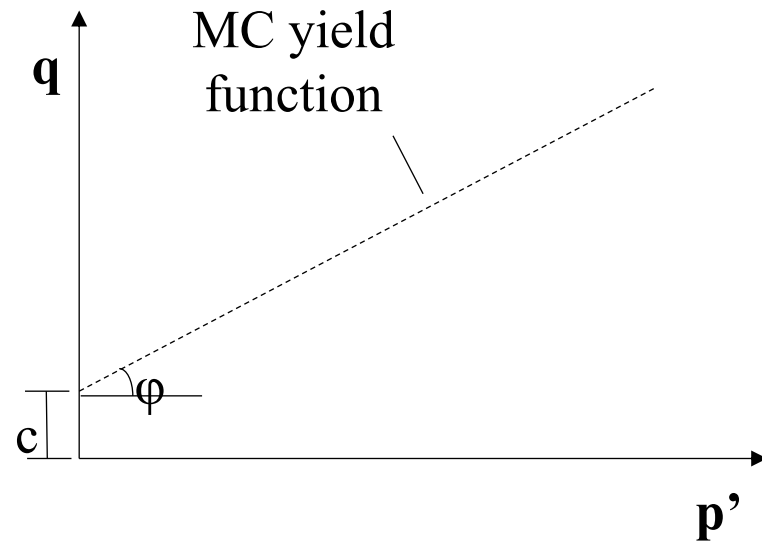

Elastic behavior:

E : young modulus

ν : Poisson ratio

Post failure behavior:

ϕ : friction angle

c : cohesion

ψ : dilatancy angle

Mohr Coulomb:

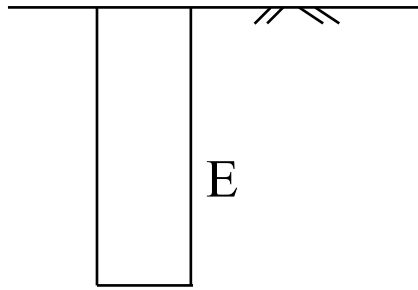

(a) Stress dependent elastic properties

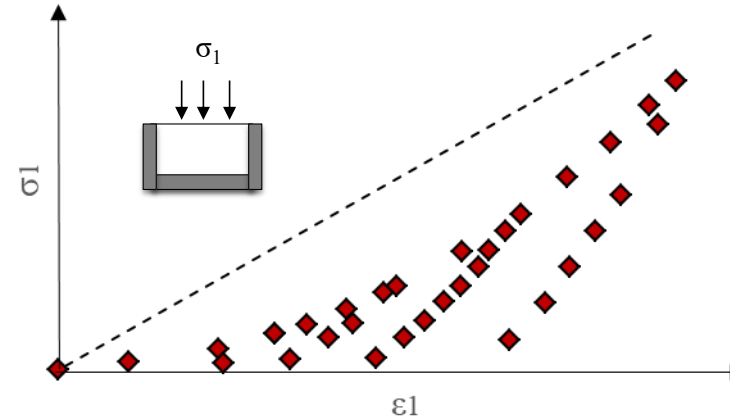

(c) Oedometer test results

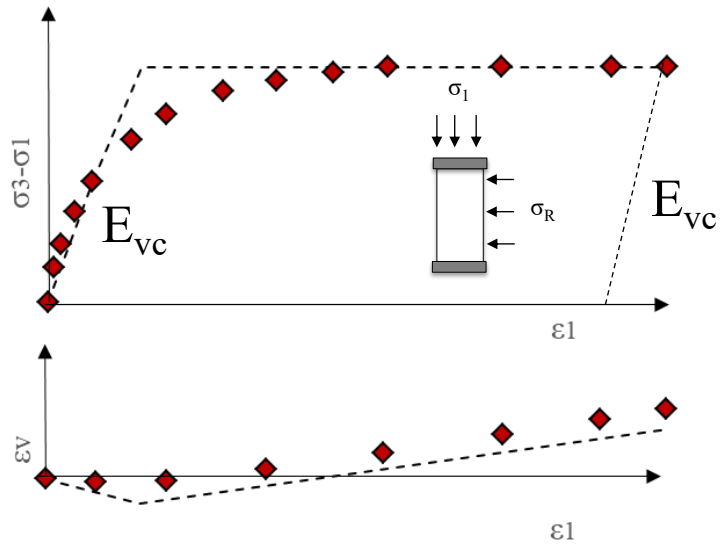

(b) Triaxial test results

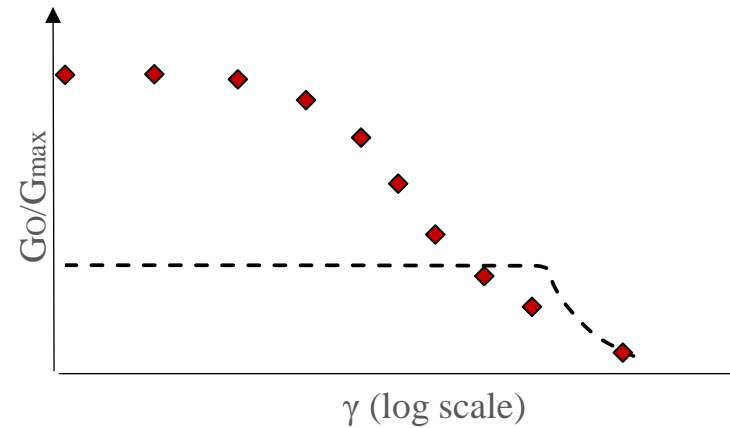

(d) Small strain Stiffness

Used for preliminary estimate with 50% error in displacement.

Soil Constitutive laws

Dominating properties in excavations:

unrealistic bottom heave [unloading/reloading stiffness]

Unrealistic surface settlement [pre yielding stiffness]

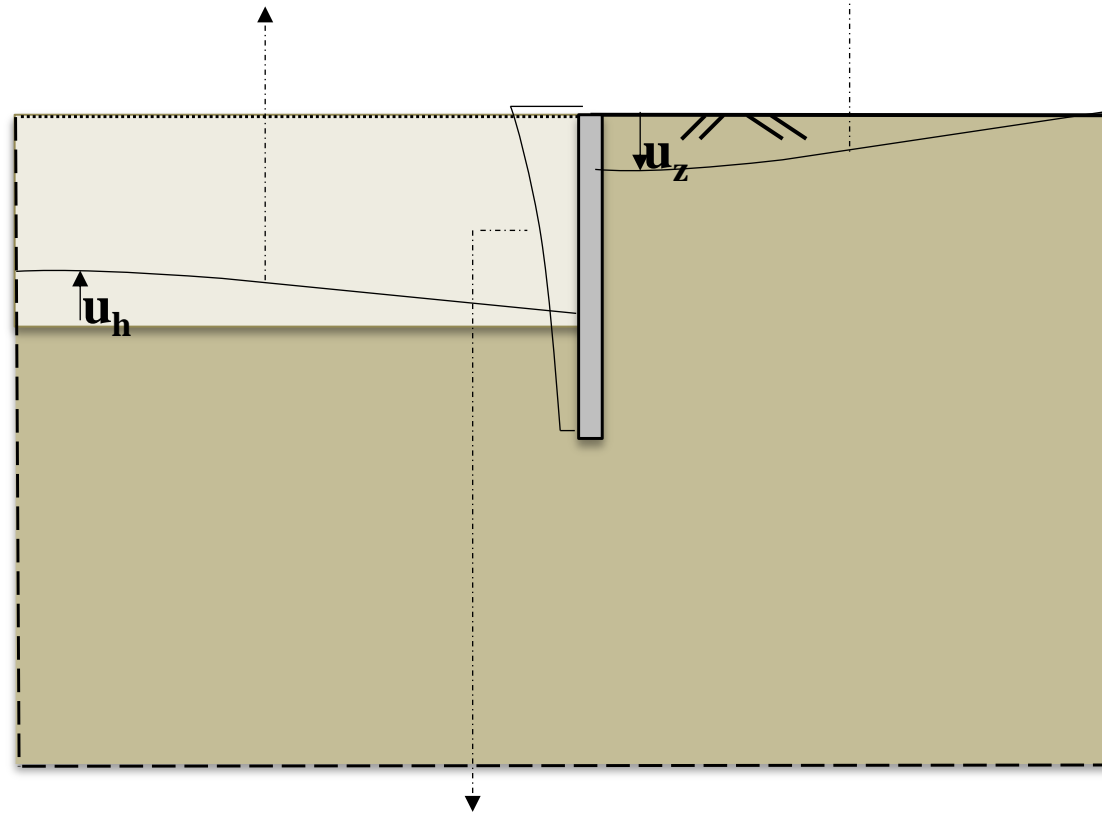

Unrealistic wall displacement without [small strain stiffness and stress dependency]

Soil Constitutive laws

Soil hardening:

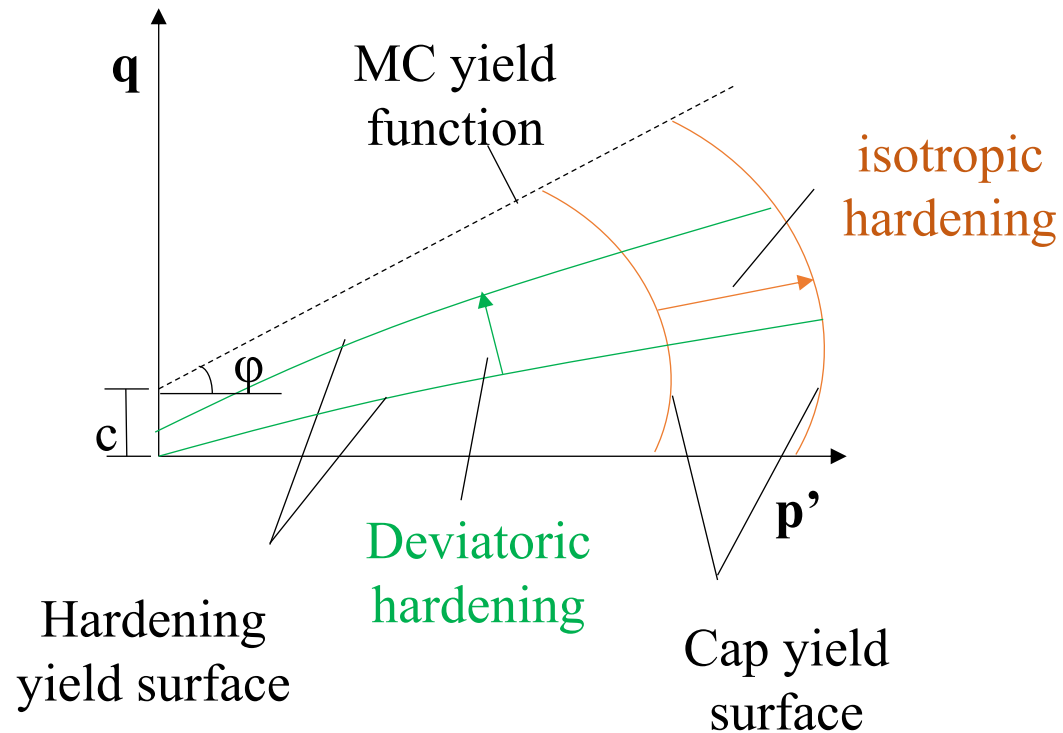

Stiffness parameters:

E_{50} : secant stiffness in standard triaxial test
 E_{oed} : tangent stiffness for primary oedometer loading

E_{ur} : unloading/reloading stiffness

ν_{ur} : Poisson ratio for unloading/reloading

$K_{0,\text{nc}}$: K_0 value for normal consolidation

m : power of stress dependent stiffness

P_{ref} : reference σ_1 pressure

ψ : dilatancy angle

Strength parameters:

ϕ : friction angle

c : cohesion

Soil Constitutive laws

Soil hardening:

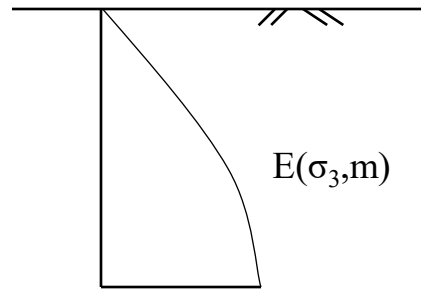

(a) Stress dependent elastic properties

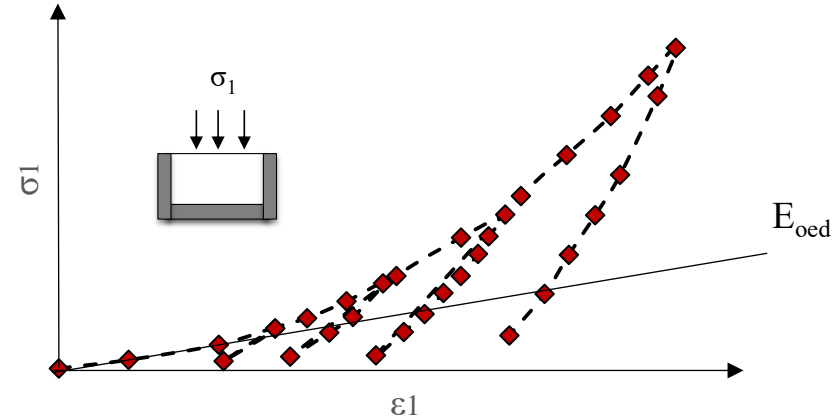

(c) Oedometer test results

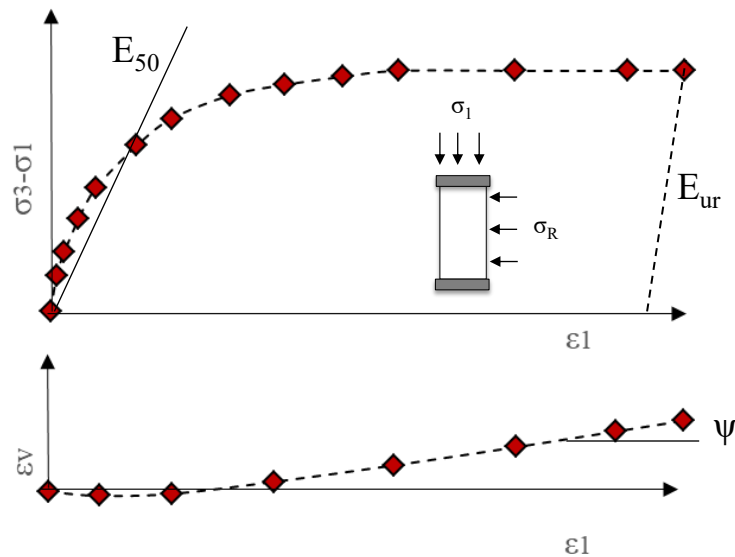

(b) Triaxial test results

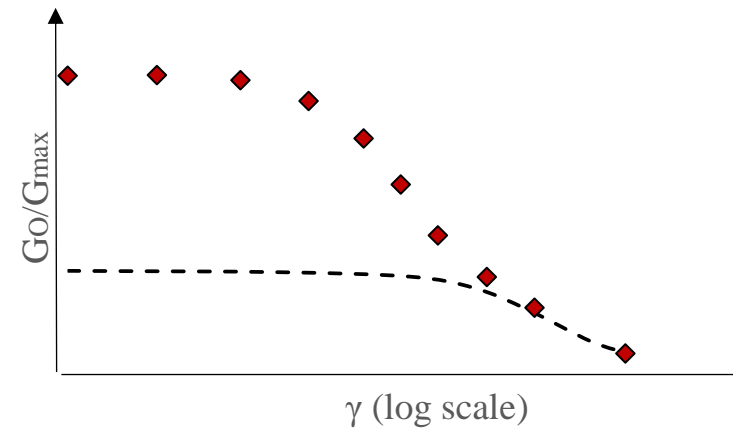

(d) Triaxial test results

Small strain Soil hardening:

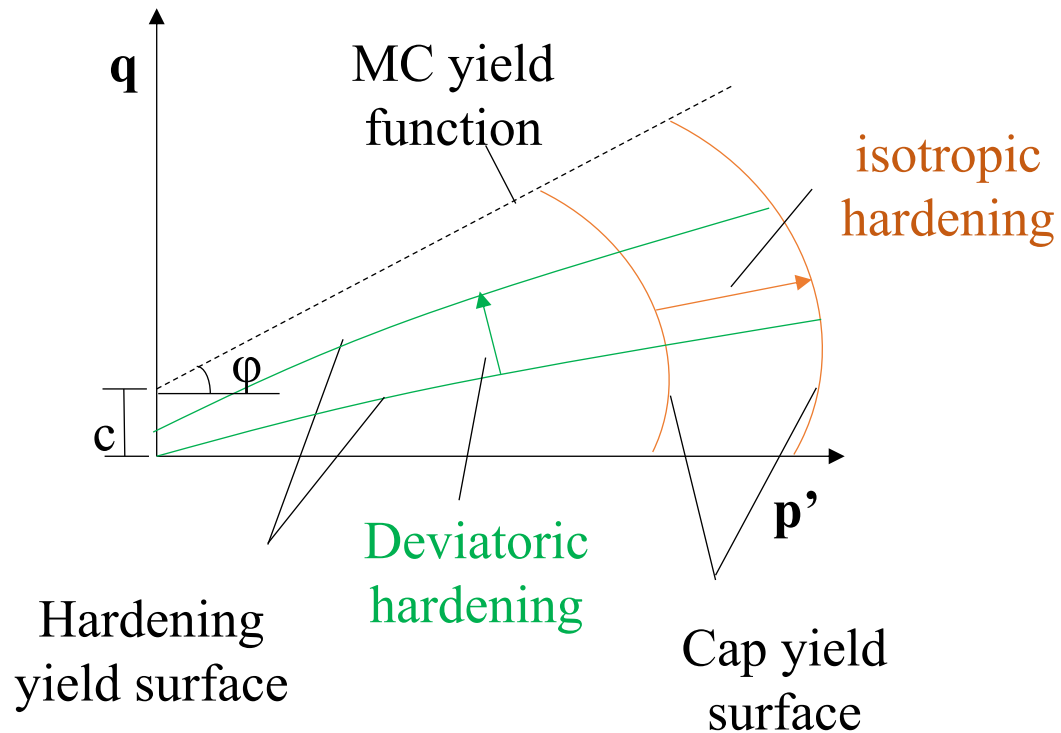

Stiffness parameters:

E_{50} : secant stiffness in standard triaxial test
 E_{oed} : tangent stiffness for primary oedometer loading

E_{ur} : unloading/reloading stiffness

ν_{ur} : Poisson ratio for unloading/reloading

$K_{0,\text{nc}}$: K_0 value for normal consolidation

m : power of stress dependent stiffness

P_{ref} : reference σ_1 pressure

ψ : dilatancy angle

Strength parameters:

ϕ : friction angle

c : cohesion

Very small strain stiffness parameters:

$E_{0,\text{ref}}$: initial young modulus

$\gamma_{0.7}$: shear strain for 70% shear modulus reduct.

Soil Constitutive laws

Small strain Soil hardening:

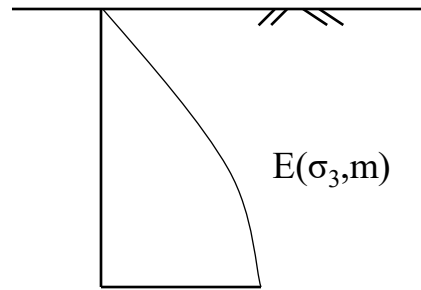

(a) Stress dependent elastic properties

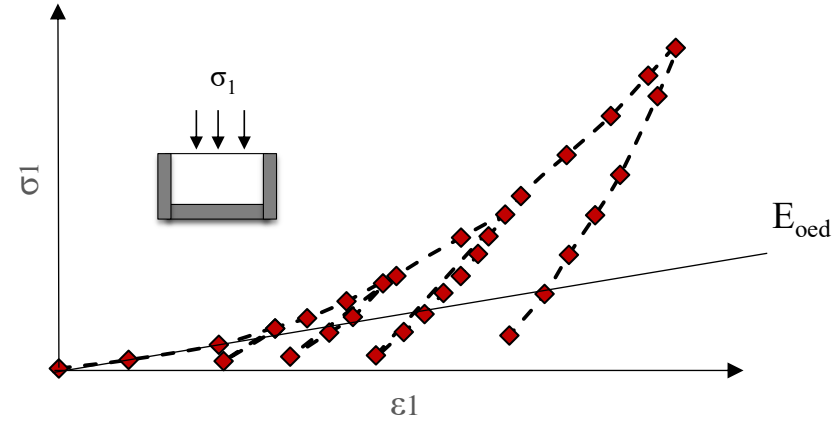

(c) Oedometer test results

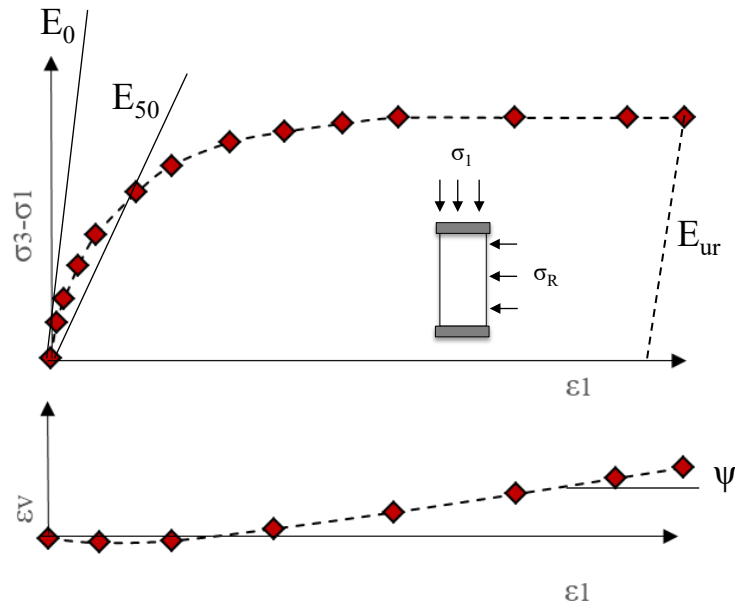

(b) Triaxial test results

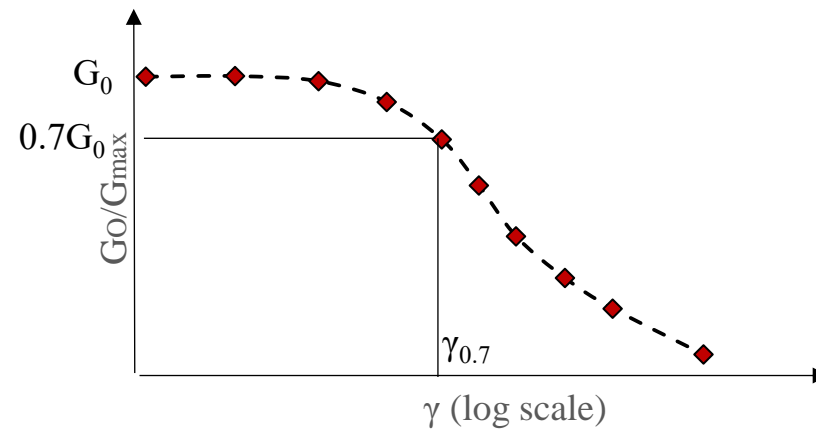

(d) Triaxial test results

Soil Constitutive laws

Modified Mohr Coulomb:

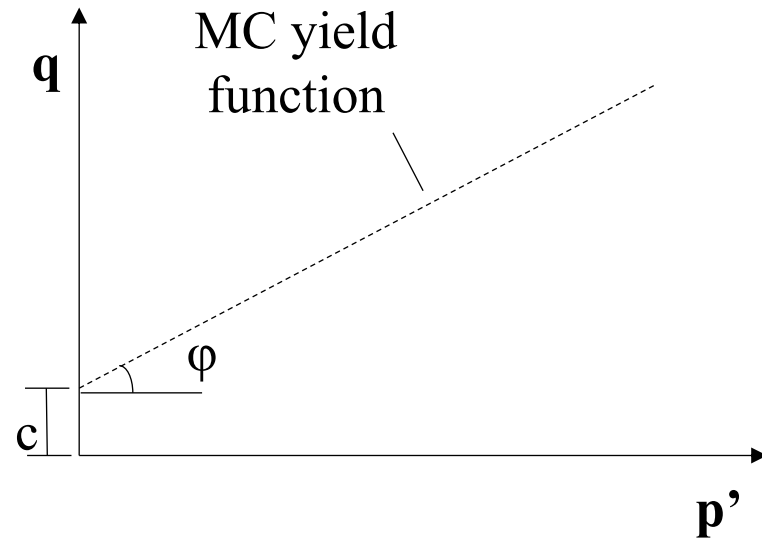

$$(\sigma_1 - \sigma_3)/2 = (\sigma_1 + \sigma_3)/2 * \tan(\varphi) + c$$

Stiffness parameters:

E: young modulus

v: Poisson ration

ψ: dilatancy angle

m: power of stress dependent stiffness

P_{ref}: reference σ_1 pressure

Strength parameters:

φ: friction angle

c: cohesion

Soil Constitutive laws

Modified Mohr Coulomb:

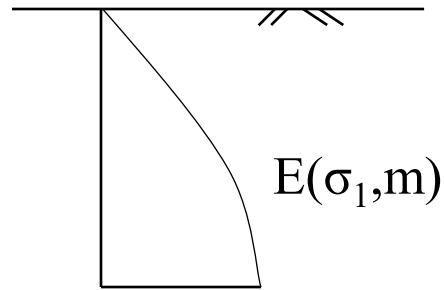

(a) Stress dependent elastic properties

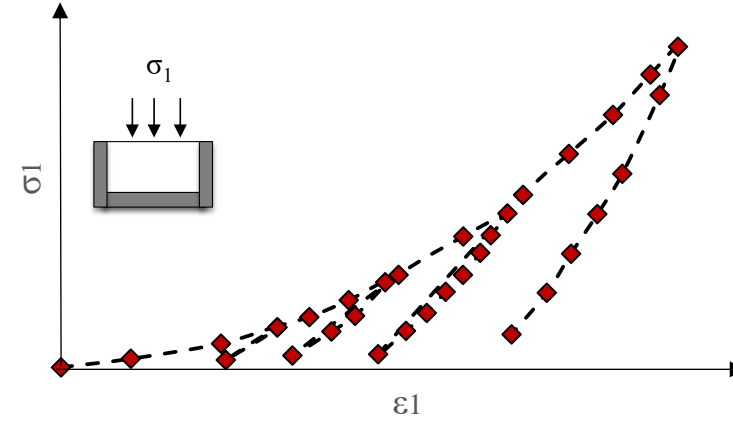

(c) Oedometer test results

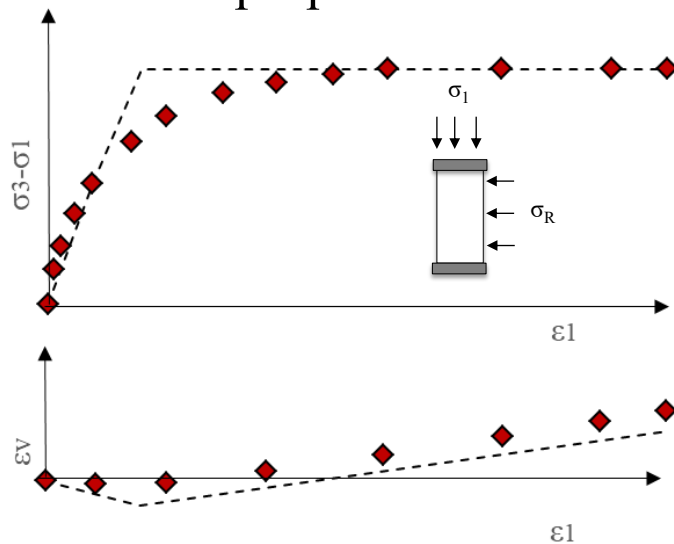

(b) Triaxial test results

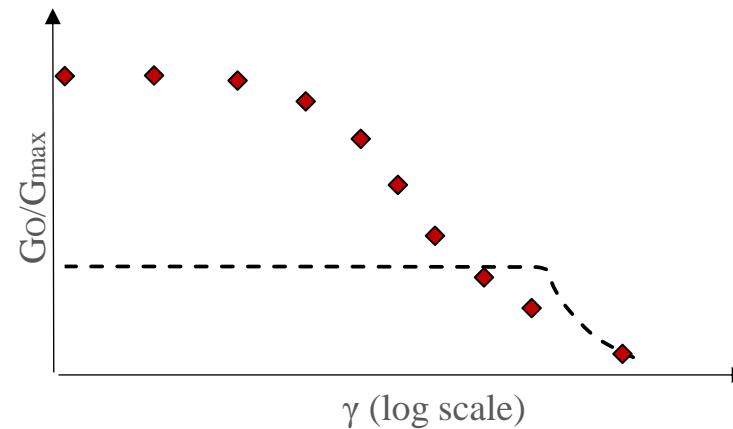

(d) Small strain Stiffness

Hoek Brown:

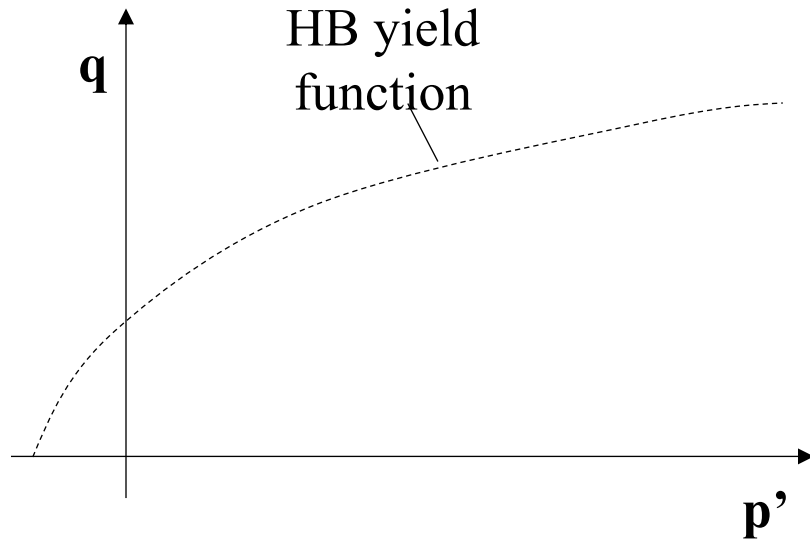

Stiffness parameters:

E: young modulus

v: Poisson ration





ψ : dilatancy angle

Strength parameters:

GSI: geological strength index

D: disturbance factor

σ_{ci} : compressive strength of intact rock

Appearance of rock mass	Description of rock mass	Suggested value of D
	Excellent quality controlled blasting or excavation by Tunnel Boring Machine results in minimal disturbance to the confined rock mass surrounding a tunnel.	$D = 0$
	Mechanical or hand excavation in poor quality rock masses (no blasting) results in minimal disturbance to the surrounding rock mass. Where squeezing problems result in significant floor heave, disturbance can be severe unless a temporary invert, as shown in the photograph, is placed.	$D = 0$ $D = 0.5$ No invert
	Very poor quality blasting in a hard rock tunnel results in severe local damage, extending 2 or 3 m, in the surrounding rock mass.	$D = 0.8$
	Small scale blasting in civil engineering slopes results in modest rock mass damage, particularly if controlled blasting is used as shown on the left hand side of the photograph. However, stress relief results in some disturbance.	$D = 0.7$ Good blasting $D = 1.0$ Poor blasting
	Very large open pit mine slopes suffer significant disturbance due to heavy production blasting and also due to stress relief from overburden removal. In some softer rocks excavation can be carried out by ripping and dozing and the degree of damage to the slopes is less.	$D = 1.0$ Production blasting $D = 0.7$ Mechanical excavation

(Hoek et al 2002)

Soil Constitutive laws

The selection and parametrization of a constitutive law is **highly** influential but also **highly** complex!

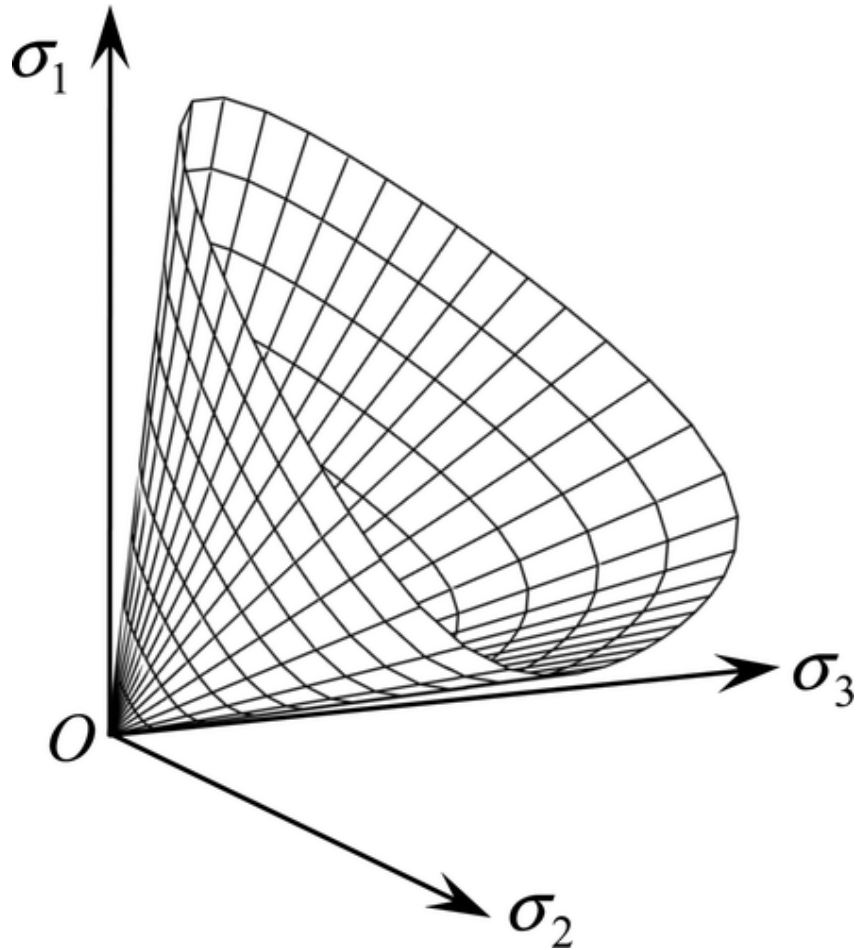

- Limited mathematical models
- High uncertainty in input data

Soil Constitutive laws

Selection of constitutive law?

1) Level of strain

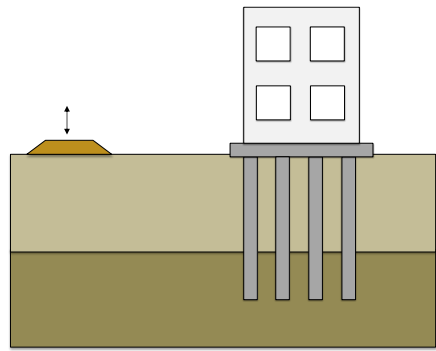

Railway vibration

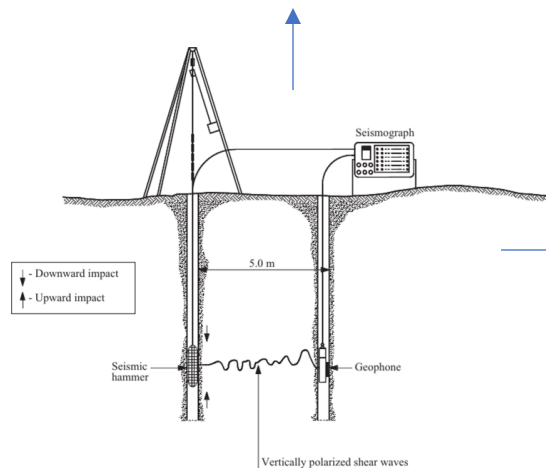

Cross hole test

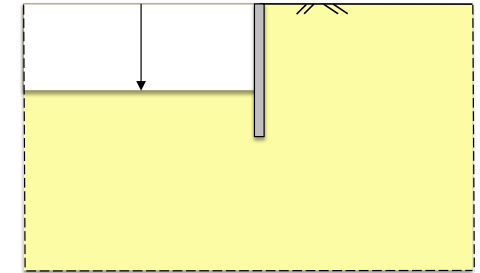
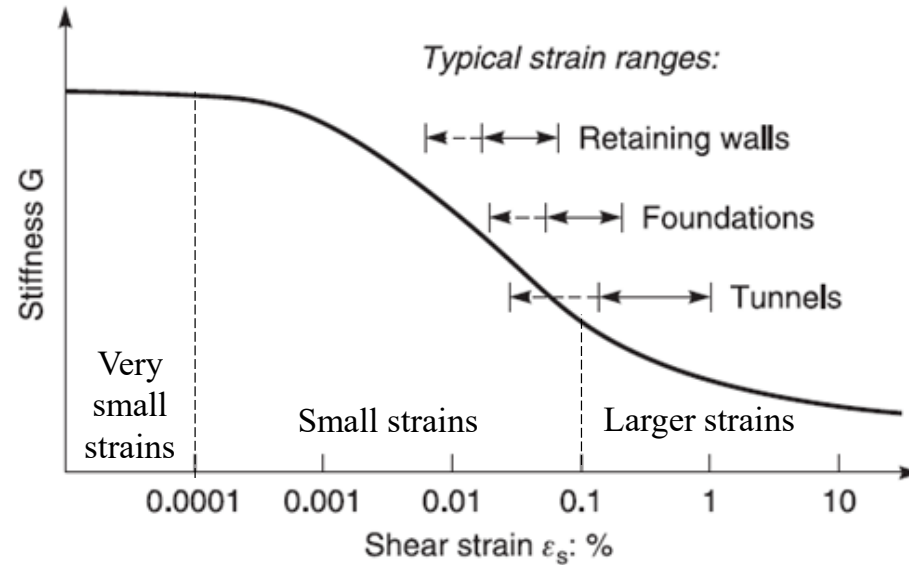

Excavation

Seismic down/ cross hole tests

Conventional soil testing

local gauges

Soil Constitutive laws

Selection of constitutive law?

2) Stress paths

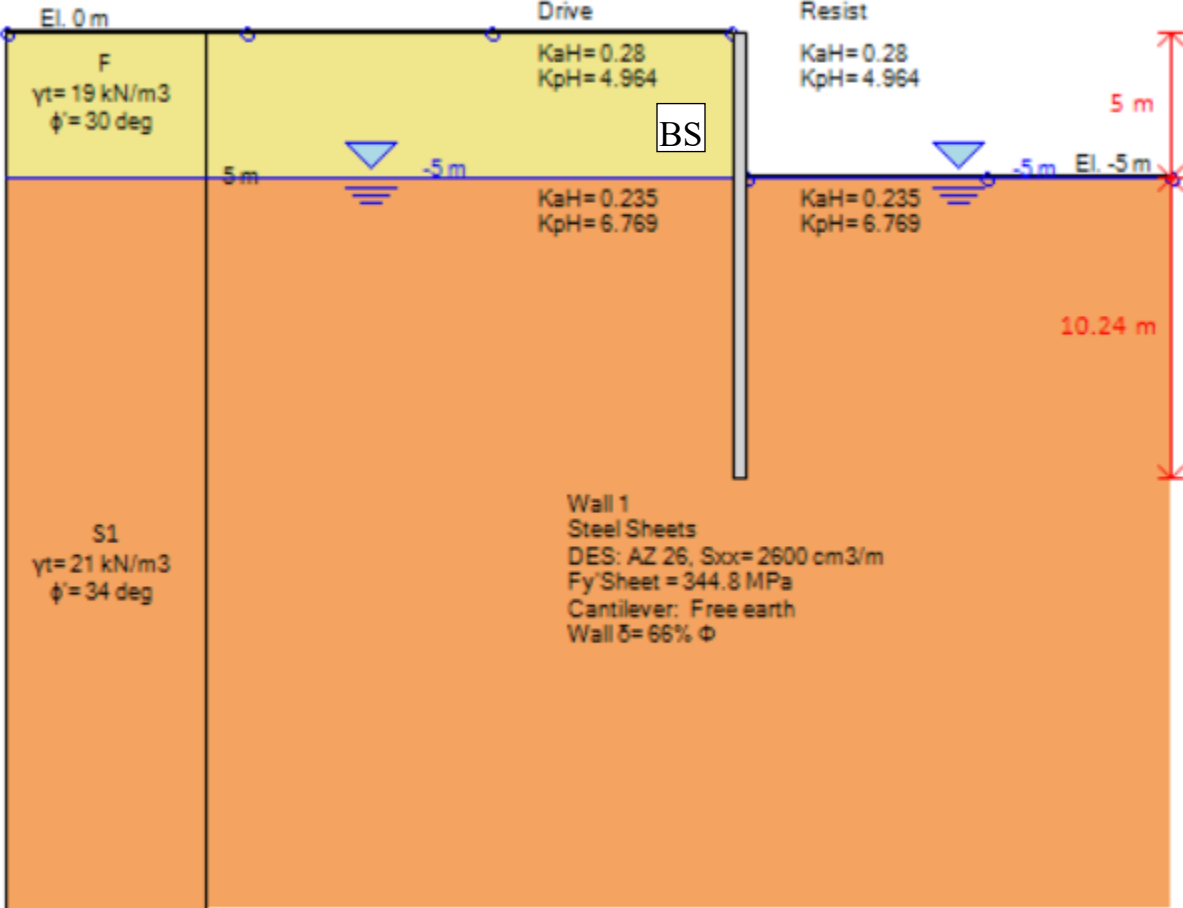
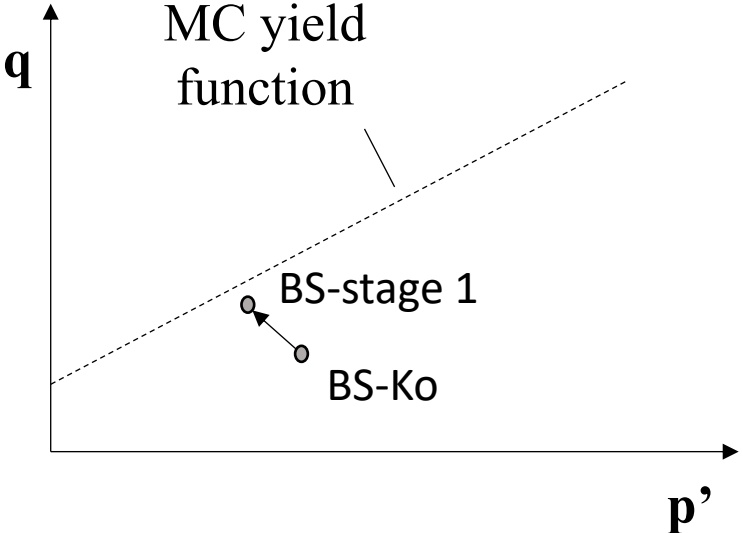
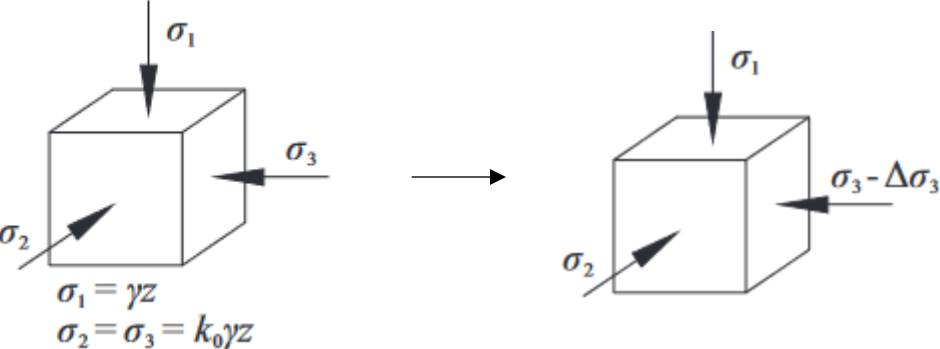

Soil Constitutive laws

Selection of constitutive law?

2) Stress paths

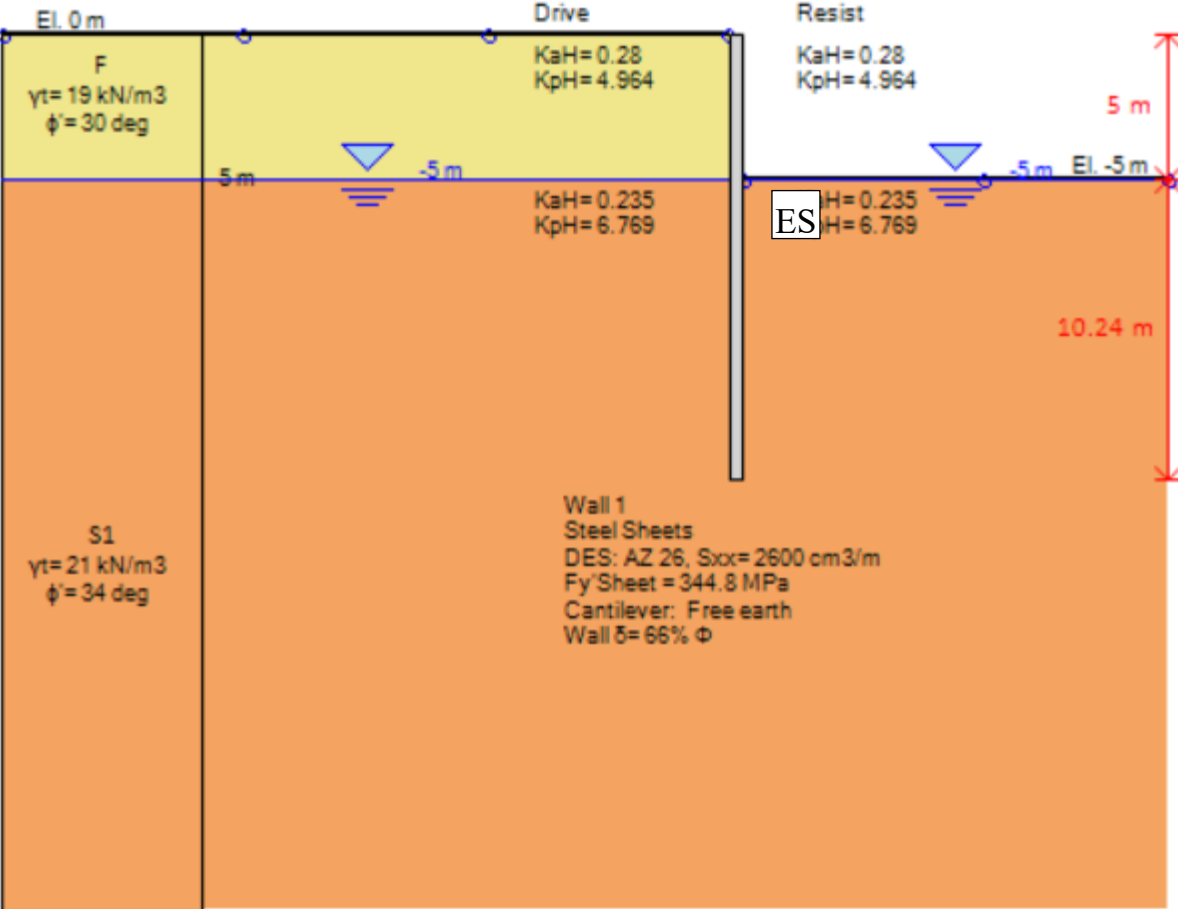
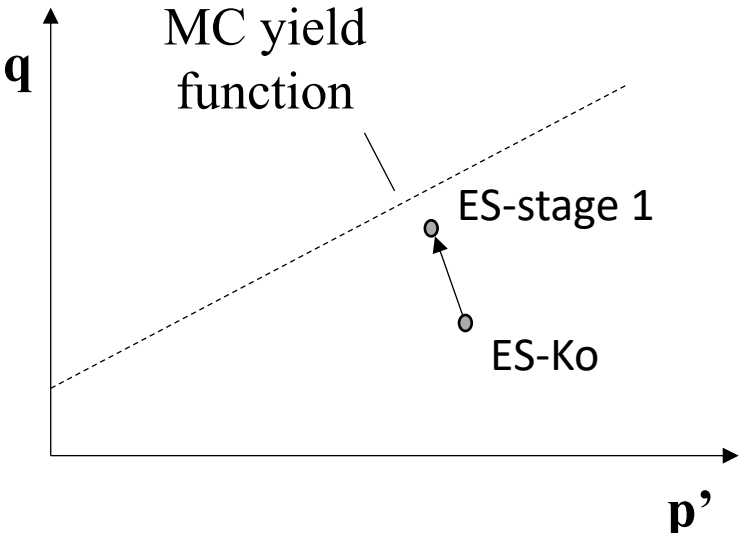
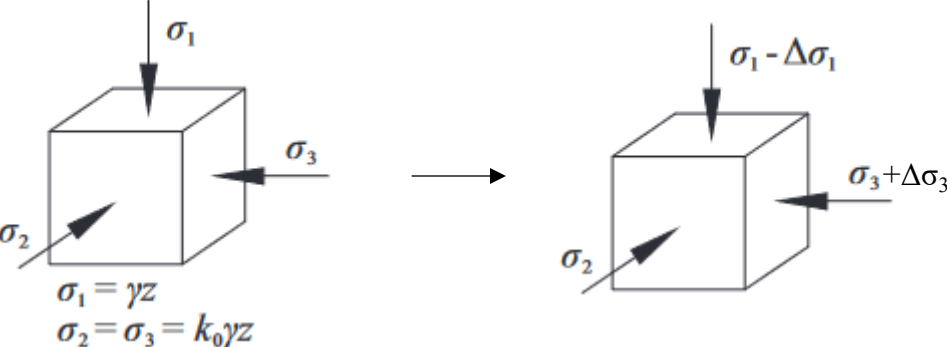

Soil Constitutive laws

The selection and parametrization of a constitutive law is **highly** influential but also **highly** complex!

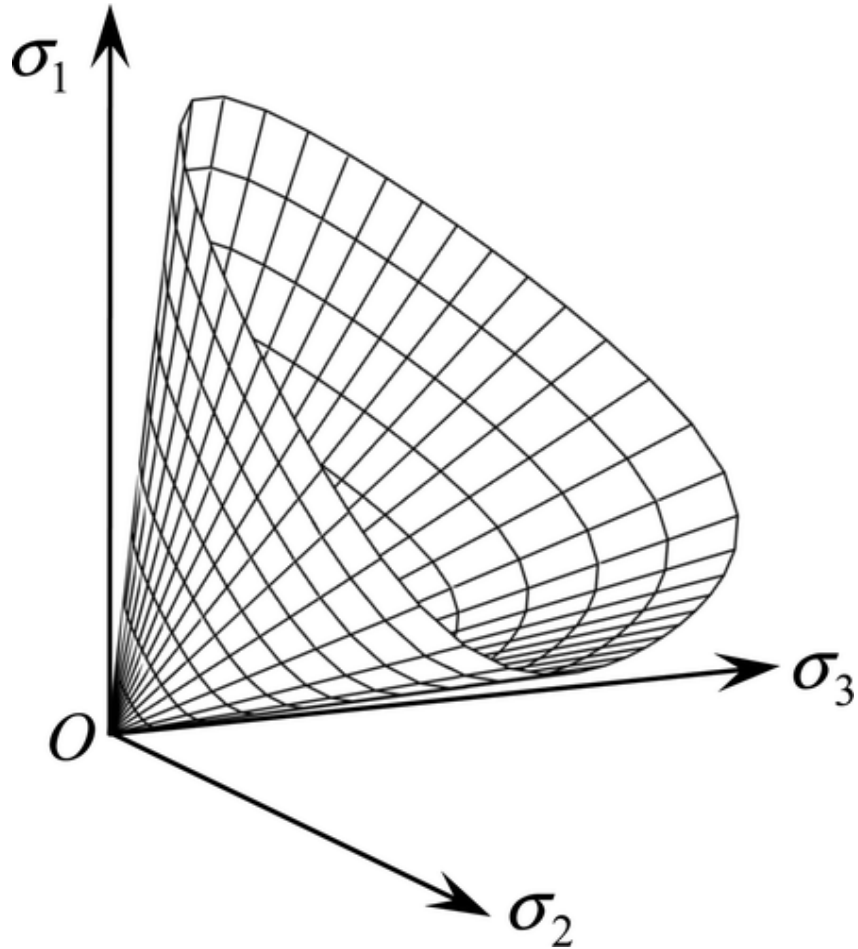

- Limited mathematical models
- High uncertainty in input data

Soil Constitutive laws

Selection of soil parameters

corelation with SPT/CPT/ and soil classification

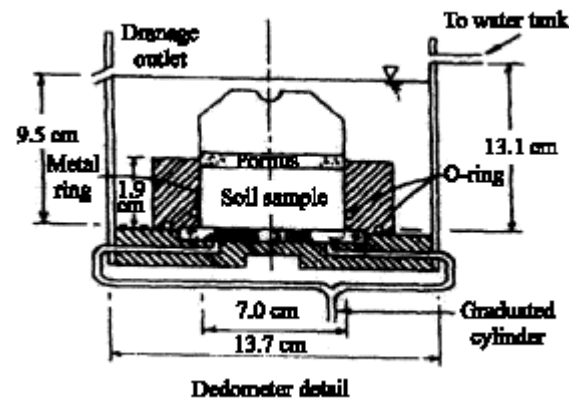
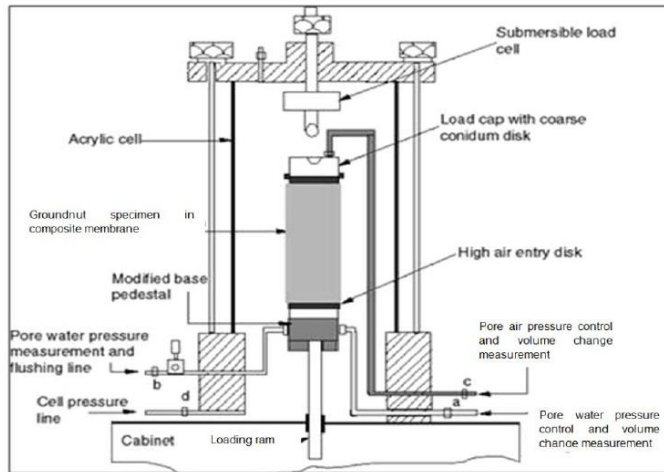

Oedometer test

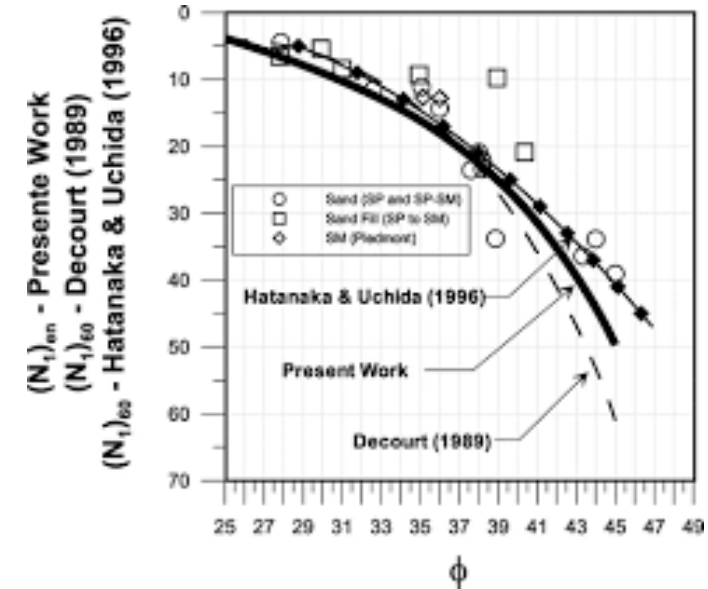

Directly from lab tests
(triaxial test, oedometer test,
direct shear test)

Local experience in the site from previous projects!

Soil Constitutive laws

Example 2: Anchored excavation in Berlin sand.



Soil Constitutive laws

Stage GF: Greenfield conditions (K_0 based imposed stress field)

Stage 0: activation of diaphragm wall

Stage 1: excavation at level -4.8m

Stage 2: activation of anchor 1 and prestressing and groundwater lowering to -9.4m

Stage 3: excavation at level -9.3m

Stage 4: activation of anchor 2 and prestressing

Stage 5: groundwater lowering to -14.5m

Stage 6: excavation at level -14.35m

Stage 7: activation of anchor 3 and prestressing

Stage 8: groundwater lowering to -17.9m

Stage 9: final excavation at level -16.8m

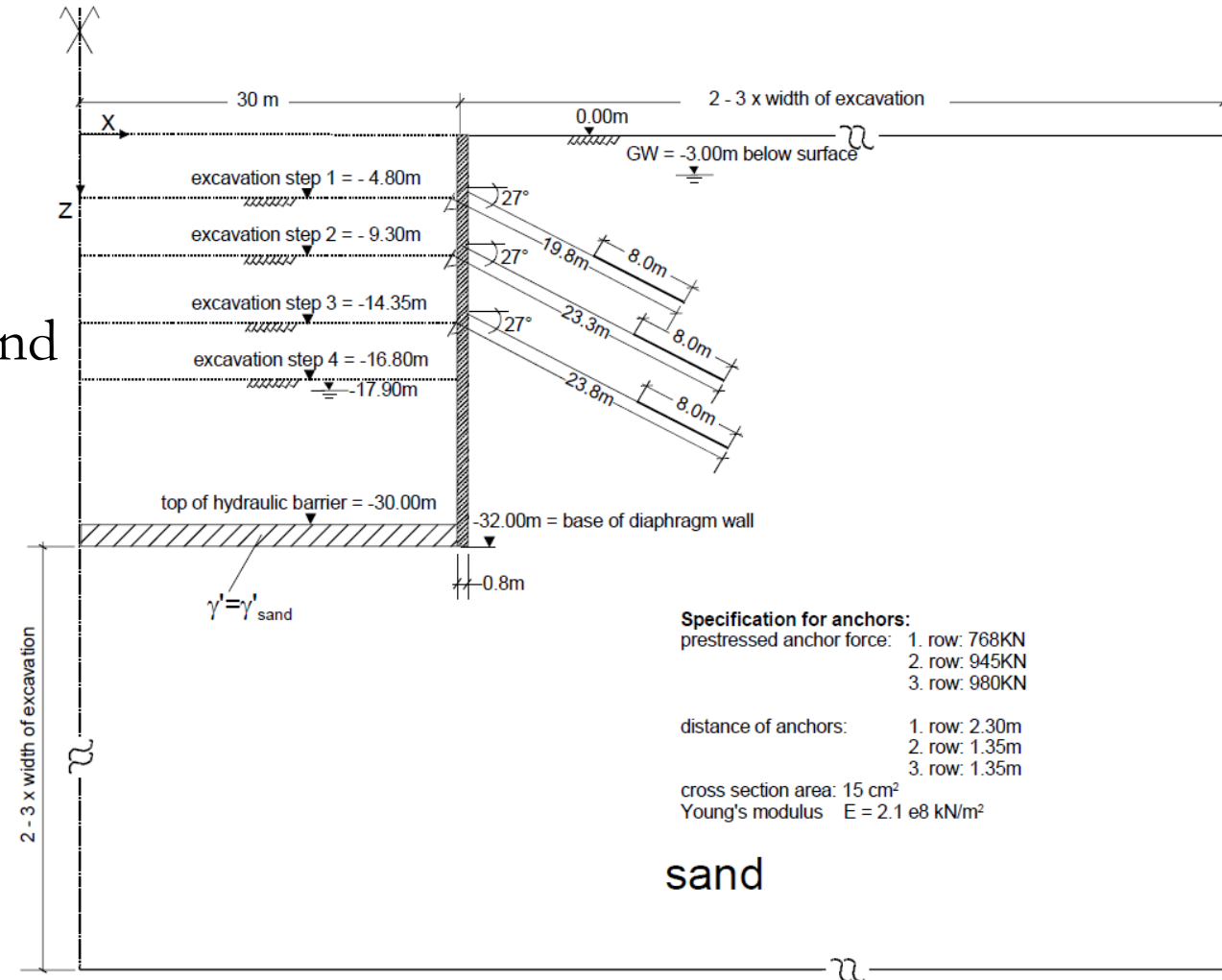

Soil Constitutive laws

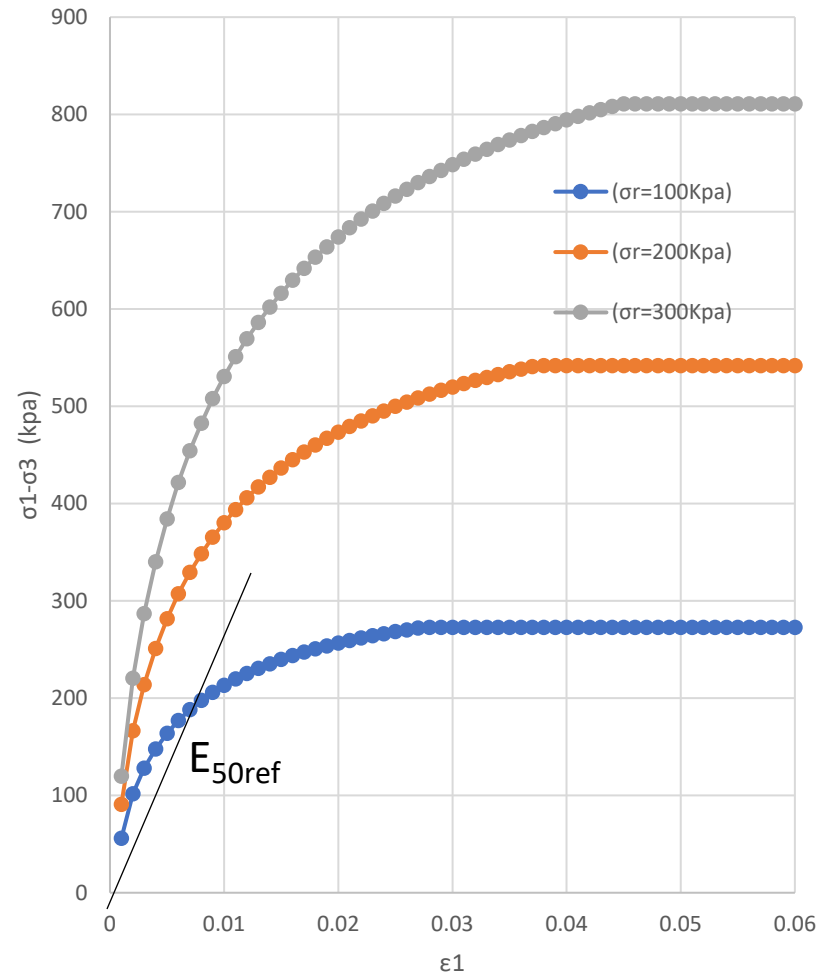

depth of layer	E_{50}^{ref}	E_{ur}^{ref}	E_{oed}^{ref}	ν	P	c	ϕ_{ur}	p_{ref}	m	R_f	R_{inter}
m	kPa	kPa	kPa	°	°	kPa	-	kPa	-	-	-
0 - 20	45 000	180 000	45 000	35	5	1.0	0.2	100	0.55	0.9	0.8
20 - 40	75 000	300 000	75 000	38	6	1.0	0.2	100	0.55	0.9	0.8
> 40	105 000	315 000	105 000	38	6	1.0	0.2	100	0.55	0.9	-

Soil Constitutive laws

Soil Types ? X

Soil Types

1. Name and Basic Soil Type
Soil Name F Color
 Description Fill

2. Soil Type - Behaviour
 Sand Show test data (SPT, CPT, Etc)
 Clean fine sands, and slightly silty sands

3. Default drained-undrained behavior for clays (See Theory Manual)
 Undrained behaviour Drained

A. General C. Elasto-plastic D. Bond E. Adv. F. Piles

4. Unit Weights - Density
 γ_t 19.625 kN/m³ γ_{bulk} 18.84 kN/m³ γ_s 9.625

5. Strength Parameters and Poisson Ratio
 Drained strength properties
 c' 1 kPa ϕ' 35 degrees
 Peak - constant vol. (for estimation)
 ϕ_{cv} Omittec degrees ϕ_{peak} Omittec degrees
 ν 0.35

6. Permeability
 K_x 9.999999 m/sec K_z 9.999999 m/sec

8. At-rest coefficients
 $KoNC$ 0.426 $nOCR$ 0.5 $Ko = KoNC * (OCR)^{nOCR}$

FEM properties (summary-tools)

Database Database OK Cancel

Soil Types ? X

Soil Types

1. Name and Basic Soil Type
Soil Name S1 Color
 Description Medium sand

2. Soil Type - Behaviour
 Sand Show test data (SPT, CPT, Etc)
 Clean fine sands, and slightly silty sands

3. Default drained-undrained behavior for clays (See Theory Manual)
 Undrained behaviour Drained

A. General C. Elasto-plastic D. Bond E. Adv. F. Piles

4. Unit Weights - Density
 γ_t 19.625 kN/m³ γ_{bulk} 18.84 kN/m³ γ_s 9.625

5. Strength Parameters and Poisson Ratio
 Drained strength properties
 c' 1 kPa ϕ' 38 degrees
 Peak - constant vol. (for estimation)
 ϕ_{cv} Omittec degrees ϕ_{peak} Omittec degrees
 ν 0.35

6. Permeability
 K_x 9.999999 m/sec K_z 9.999999 m/sec

8. At-rest coefficients
 $KoNC$ 0.384 $nOCR$ 0.5 $Ko = KoNC * (OCR)^{nOCR}$

FEM properties (summary-tools)

Database Database OK Cancel

Soil Types ? X

Soil Types

1. Name and Basic Soil Type
Soil Name sand 3 Color
 Description Rock approx.

2. Soil Type - Behaviour
 Sand Show test data (SPT, CPT, Etc)
 Clean fine sands, and slightly silty sands

3. Default drained-undrained behavior for clays (See Theory Manual)
 Undrained behaviour Drained

A. General C. Elasto-plastic D. Bond E. Adv. F. Piles

4. Unit Weights - Density
 γ_t 19.625 kN/m³ γ_{bulk} 18.84 kN/m³ γ_s 9.625

5. Strength Parameters and Poisson Ratio
 Drained strength properties
 c' 1 kPa ϕ' 38 degrees
 Peak - constant vol. (for estimation)
 ϕ_{cv} Omittec degrees ϕ_{peak} Omittec degrees
 ν 0.45

6. Permeability
 K_x 9.999999 m/sec K_z 9.999999 m/sec

8. At-rest coefficients
 $KoNC$ 0.384 $nOCR$ 0.5 $Ko = KoNC * (OCR)^{nOCR}$

FEM properties (summary-tools)

Database Database OK Cancel

10.1 Loading Elasticity Parameters
 $Eload$ 45000 kPa exp 0.55 $Pref$ 100 kPa
 α_v 0 α_h 1

10.3 Reloading Elasticity Modulus
 $rEur = Eur/Eload$ 4

10.1 Loading Elasticity Parameters
 $Eload$ 75000 kPa exp 0.55 $Pref$ 100 kPa
 α_v 0 α_h 1

10.3 Reloading Elasticity Modulus
 $rEur = Eur/Eload$ 4

10.1 Loading Elasticity Parameters
 $Eload$ 105000 kPa exp 0.55 $Pref$ 95.8 kPa
 α_v 0 α_h 3

10.3 Reloading Elasticity Modulus
 $rEur = Eur/Eload$ 3

Soil Constitutive laws

- Most participants trusted the strength indicated from the experiments
- stiffness generated from the tests was considered too low by many participants
- significant variation was observed however in the assumption of the dilatancy angle ψ , ranging from 0° to 15° .

Soil Constitutive laws

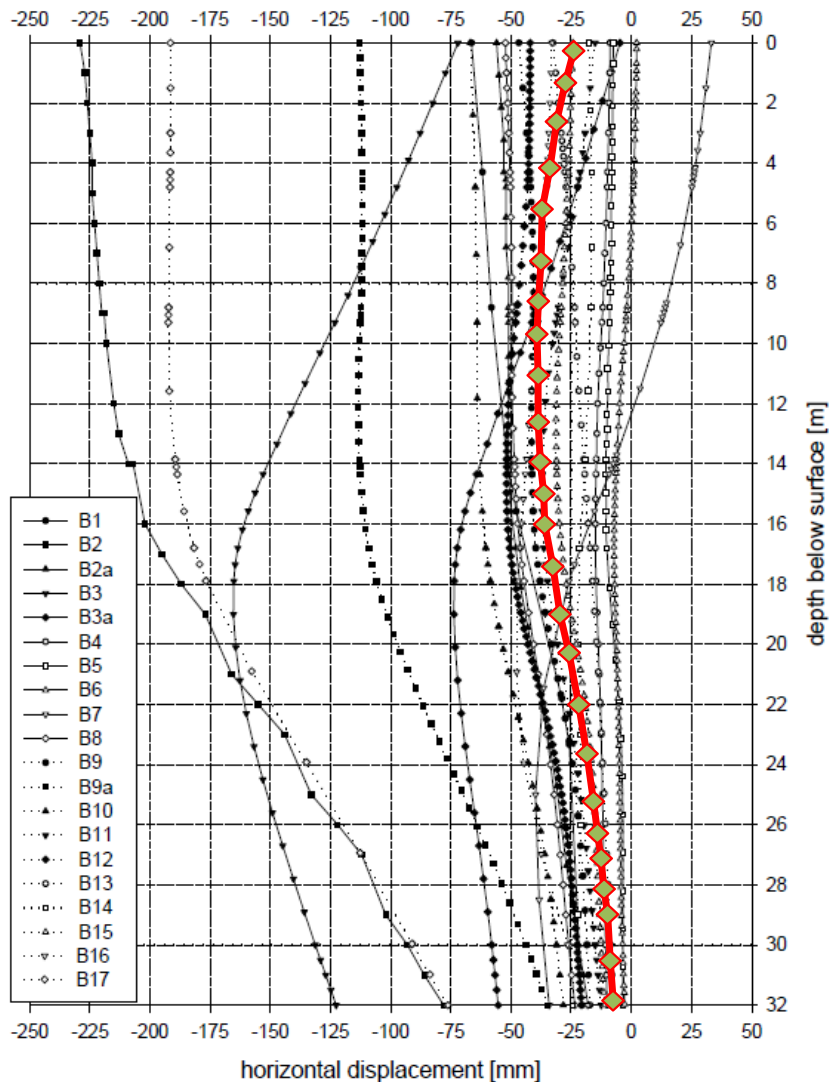

- Some of the participants used an incorrect stiffness due to misleading lab tests
- some participants incorrectly calculated the prestress force
- Mohr coulomb based models
- Fixed anchors
- the difference in modelling the groundwater lowering (0.5-1.5cm)

Major issues where caused by the selection of the soil properties based on lab tests (participants based on literature and local experience had better results).

Good practice in FEM model construction

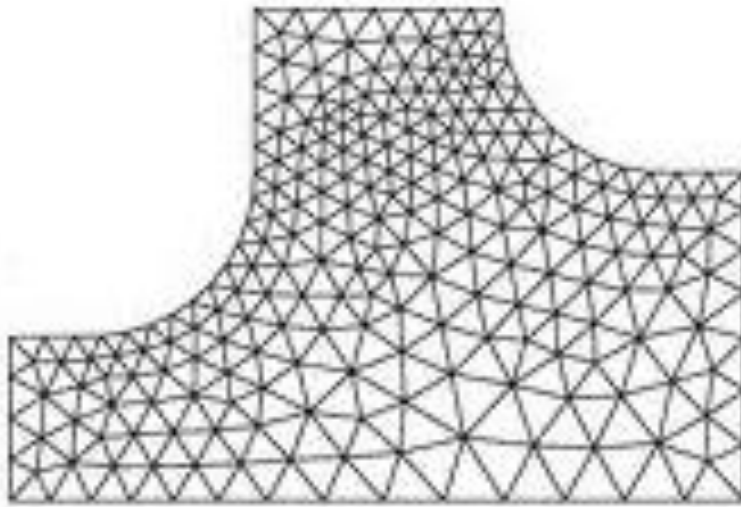

Meshing

Meshing and boundaries

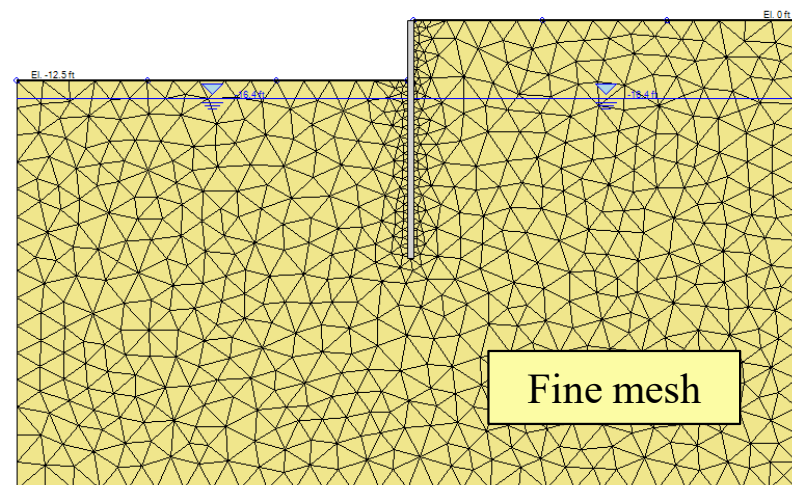
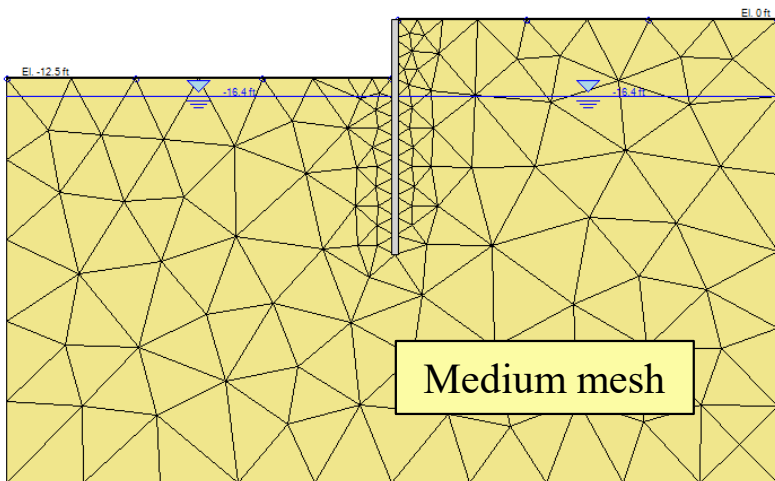
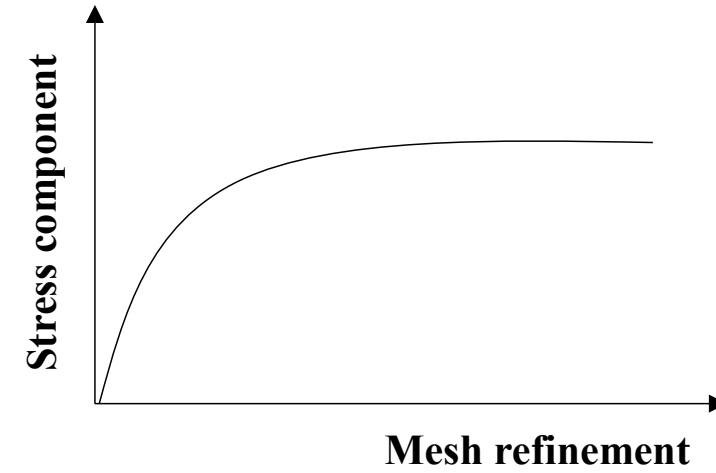
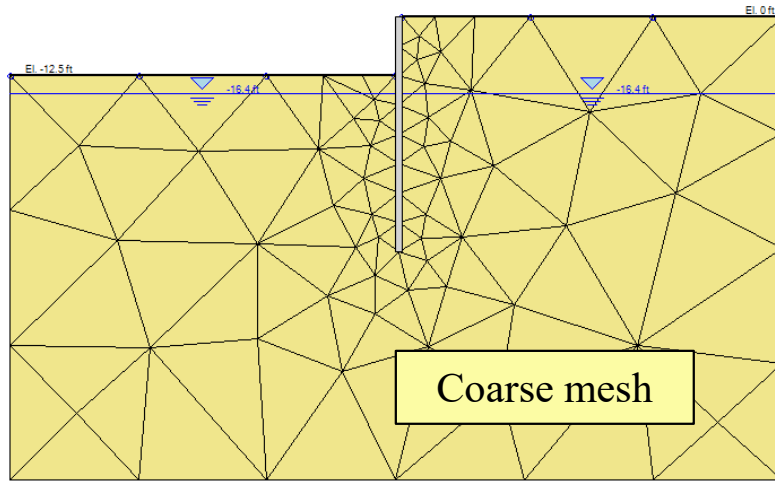

Meshing and boundaries

Boundary conditions

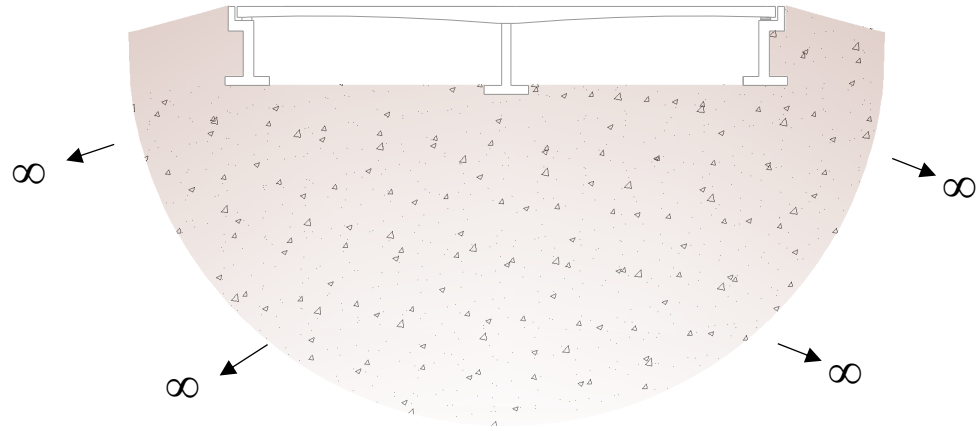

Reality: semi-infinite soil medium

FEM model: truncated boundaries

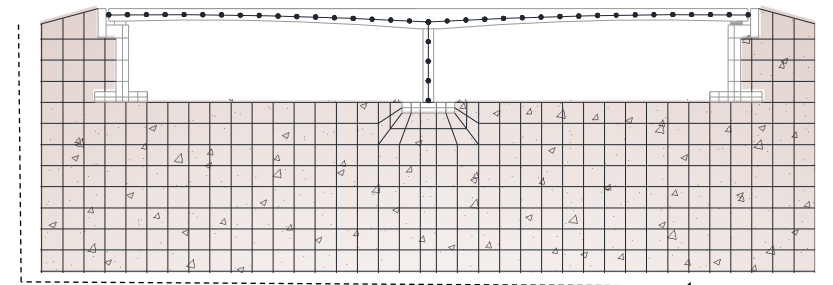

Artificial boundaries

Meshing and boundaries

Soil medium boundaries

Semi-infinite side: based on surface settlement accuracy
(1.5 to 3 times the excavation width)

symmetry side :
half distance

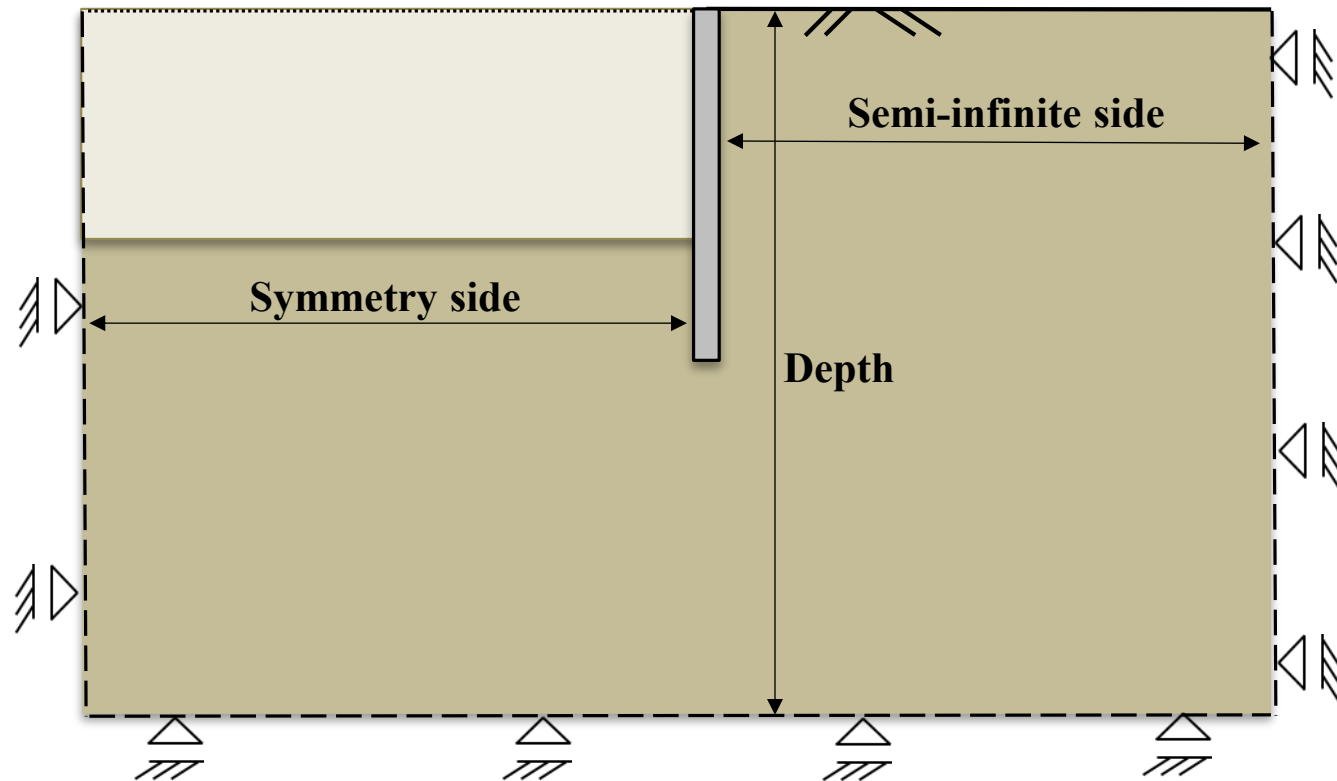

Depth : a stiff and strong layer is a good location to cut your model

Meshing and boundaries

Example 3: Boundary dimensions

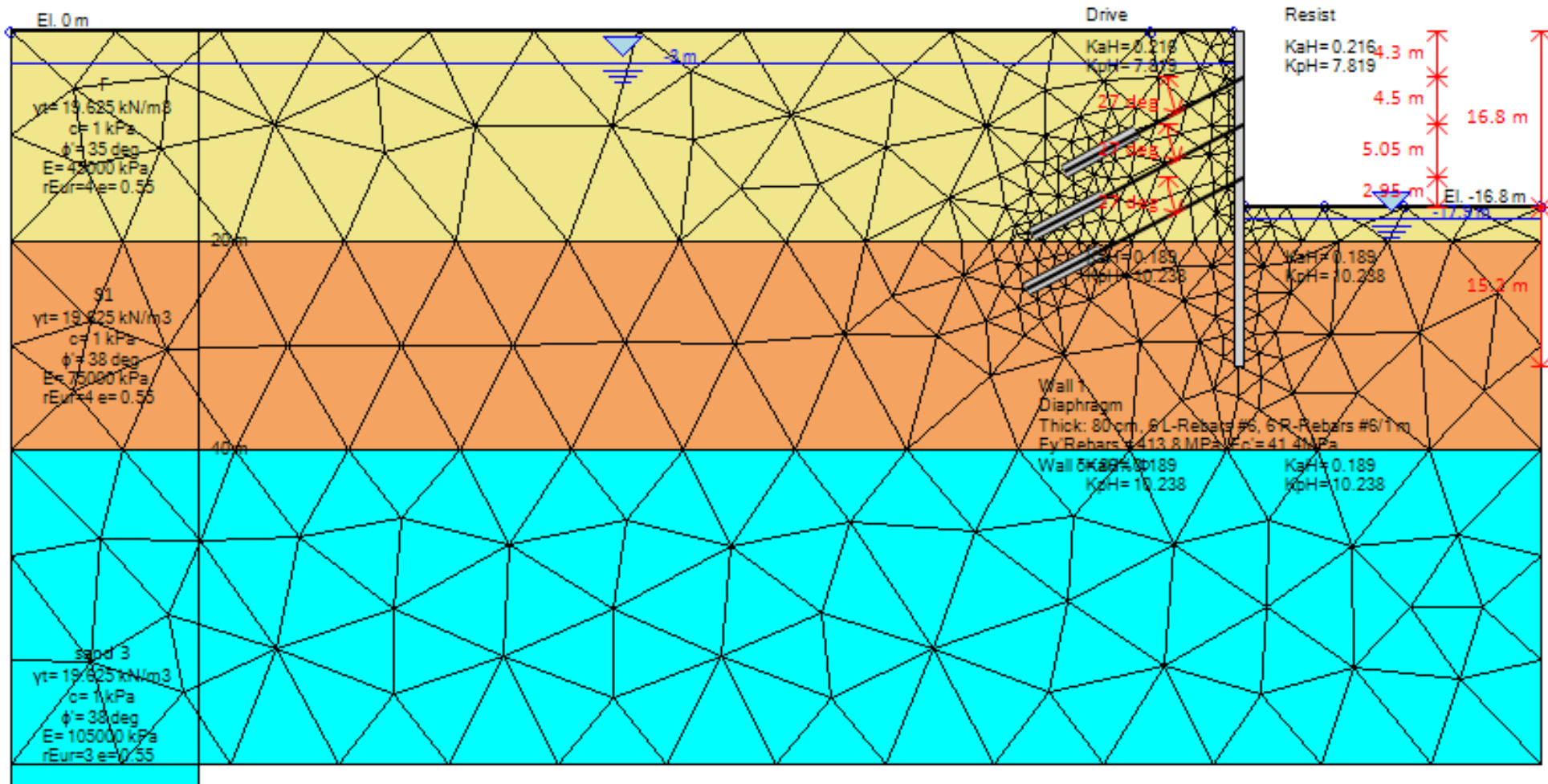

Meshing and boundaries

Example 3: Boundary dimensions

Change in mesh

Edit FEM General Properties

Mesh Preferences

Level of Mesh:

Refine stage surfaces with additional points

Analysis preferences

Non Linear Solver:

Calculate initial stress by imposing Ko conditions (gravity loading analysis otherwise)

Hardening Soil Model Solution

Change in semi-infinite side

Design Section Name and General Data

1. Design Section Name

3. Boundaries / Model Limits

Top m

Left m Right m

Bottom m

5. Wall In-Plane Rotation

Angle in plane from y-y' axis deg

This angle rotates the wall angle from the horizontal y-y' axis. To see the effect, change the angle say 10 degrees and go to View Top-Plan.

6. Excavation shape

Change in bottom depth

Design Section Name and General Data

1. Design Section Name

3. Boundaries / Model Limits

Top m

Left m Right m

Bottom m

5. Wall In-Plane Rotation

Angle in plane from y-y' axis deg

This angle rotates the wall angle from the horizontal y-y' axis. To see the effect, change the angle say 10 degrees and go to View Top-Plan.

6. Excavation shape

Meshing and boundaries

Example 4: symmetry conditions

Design Section Name and General Data

1. Design Section Name
New Section 2

3. Boundaries / Model Limits
Top 10 m
Left -25 m Right 12.5 m
Bottom -30 m

5. Wall In-Plane Rotation
Angle in plane from y-y' axis 0 deg
This angle rotates the wall angle from the horizontal y-y' axis. To see the effect, change the angle say 10 degrees and go to View Top-Plan.

6. Excavation shape
Long 2D excavation

OK Cancel

Top Down construction:

Stage 0 : greenfield conditions

Stage 1: installation of walls

Stage 2: excavation at depth **-1** m

Stage 3: construct top slab at -1 m

stage 4: excavation at depth -8 m

Stage 5: add a temporary prop at depth -7m

stage 6: excavation at depth -12 m

stage 7: construct floor slab at -12 m

Stage 8 : remove temporary pros

Meshing and boundaries

Example 4: symmetry conditions

Edit Train-Embankment Configuration X

Coordinates

Center Line of Embankment Xc: m

Load analysis method: AREMA (Elastic Boussinesq x 2) v

Define an embankment for the train roadway (will be modelled as external load)

Embankment Information

Train (roadway) elevation: m

Ballast unit weight: $\frac{\text{kN}}{\text{m}^3}$

Embankment width at roadway: m

Embankment slope TV to: Horizontal

Distribute train track load to base (transforms load to a strip load at base elevation)

Load analysis method: One way distribution v

Train Tracks

	xCenter	Use Absolute x coordinates	Track Spacing	Track Load	Train Designation
▶	-1.6765	<input type="checkbox"/>	1.524	116.798	E80
	1.6765	<input type="checkbox"/>	1.524	116.798	E80

Structural components and interface

Two modelling options for structural components in soil:

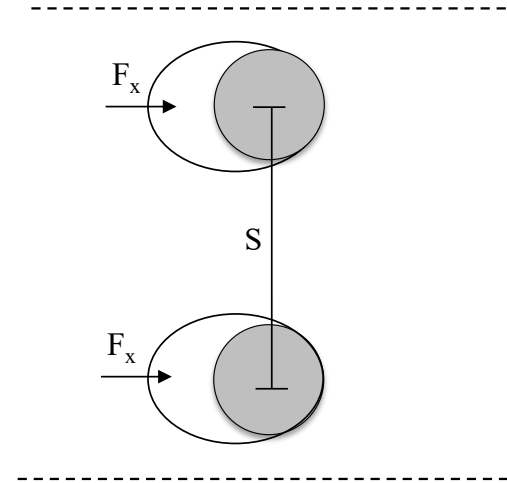
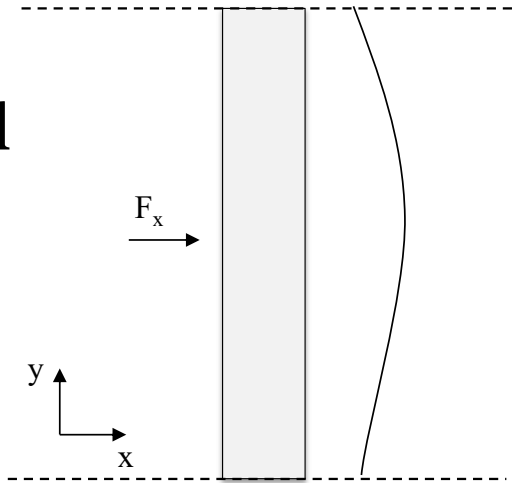

Beam method with zero thickness interface

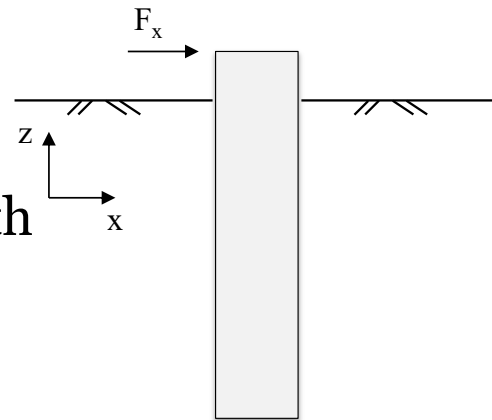

Embedded beam row method

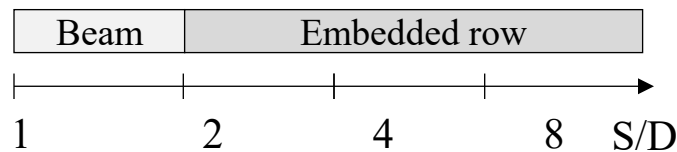
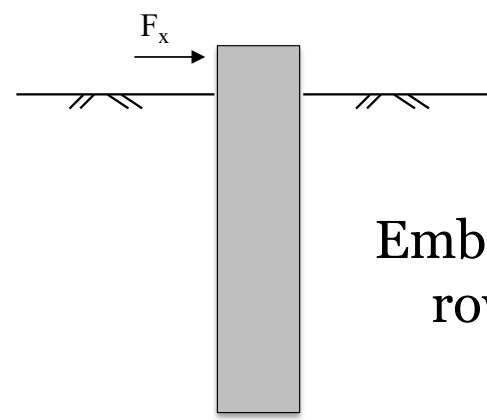

Structural components and interface

Beam method with zero thickness interface

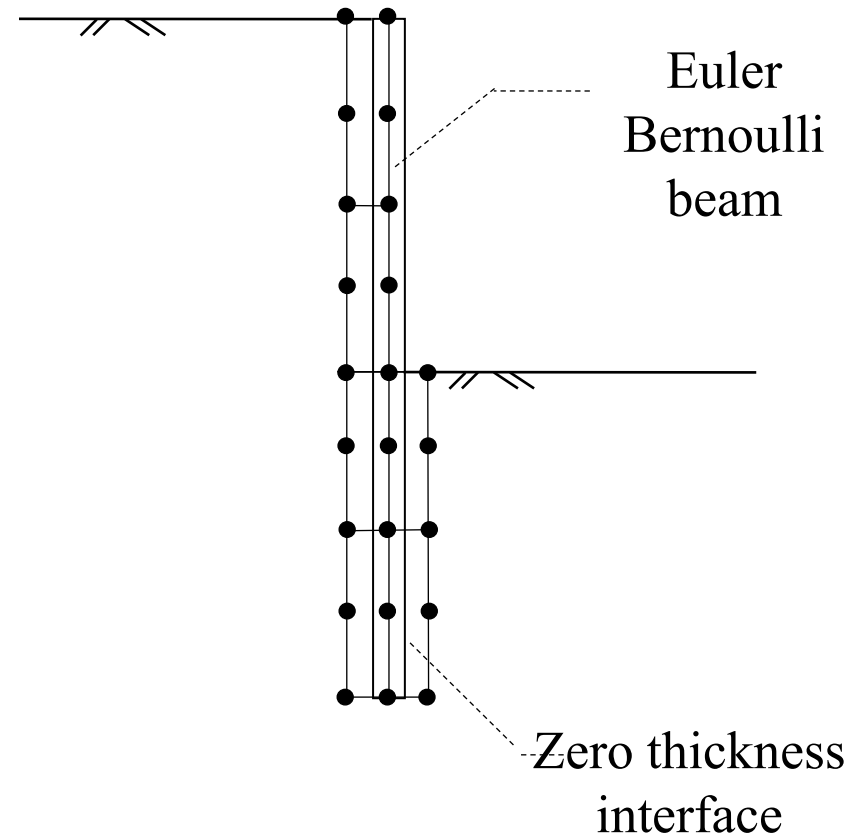

(soldier pile with lagging, sheet pile, secant pile, tangent pile, diaphragm, gravity walls)

Structural components and interface

Zero thickness element

- δ angle
- R reduction factor (Strength/Stiffness)

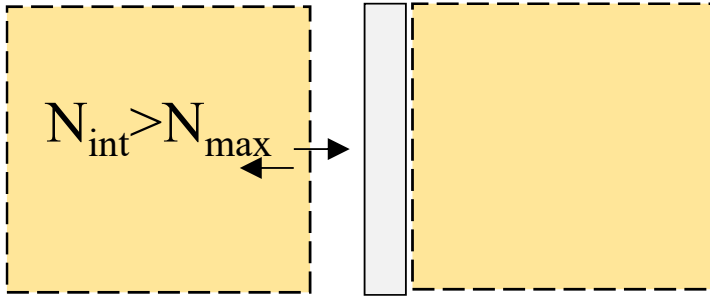

Separation
(interface tension failure)

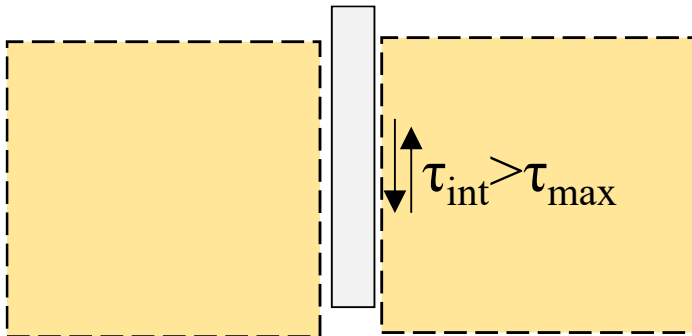

Slippage
(interface shear failure)

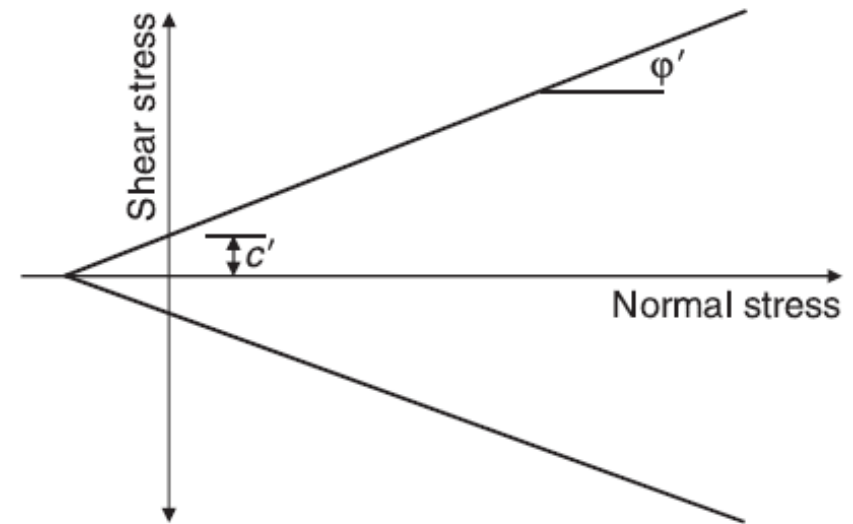

Mohr coulomb law

Structural components and interface

Embedded beam row method

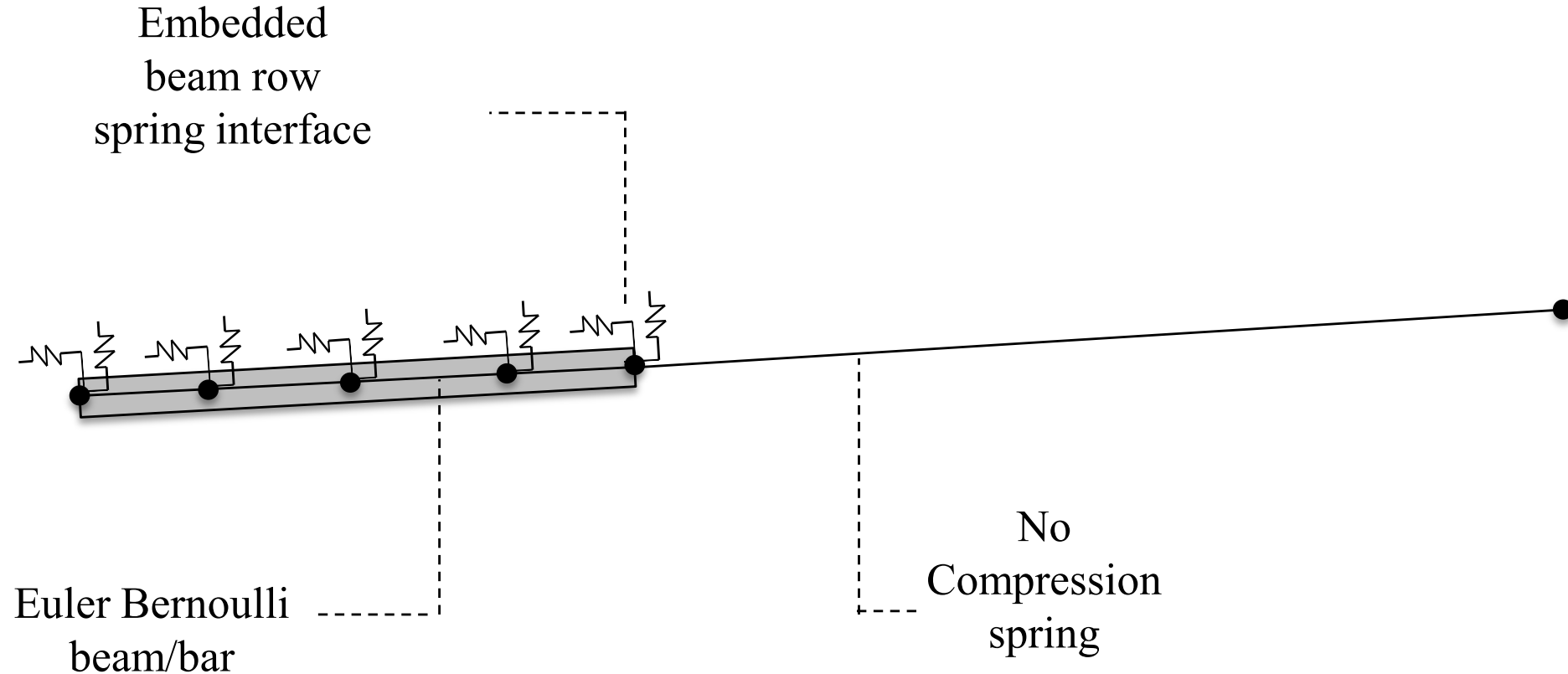

(Pile rows, tiebacks, tiedowns, soil nails, rock bolts)

Strength reduction analysis

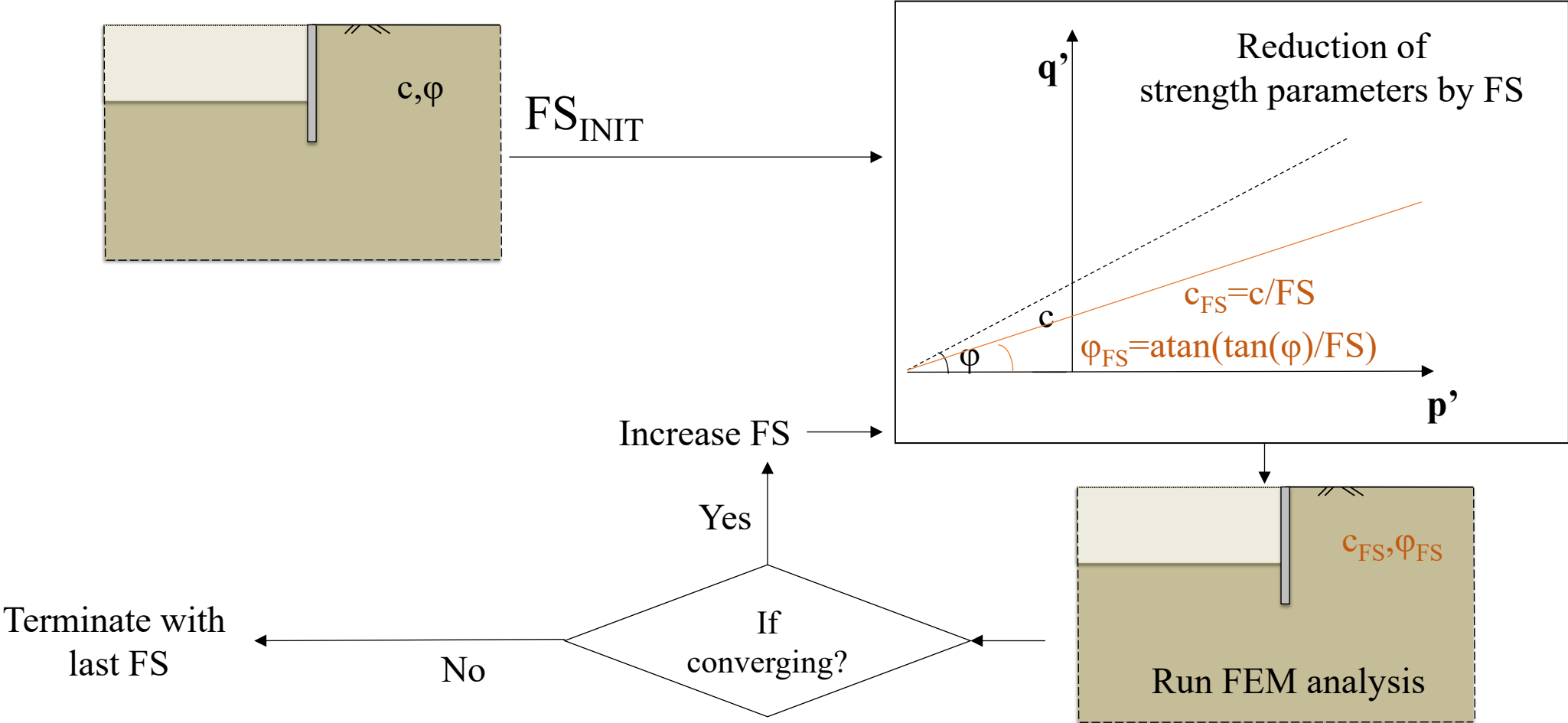

Strength reduction analysis

Example 5: Shear strength reduction analysis example

Parameter	Value	Unit
Elastic modulus	10^5	kN/m^2
Poisson's ratio	0.3	--
Unit weight	20	kN/m^3
Cohesion	10	kN/m^2
Friction angle	20	0
Dilatancy angle	0	0

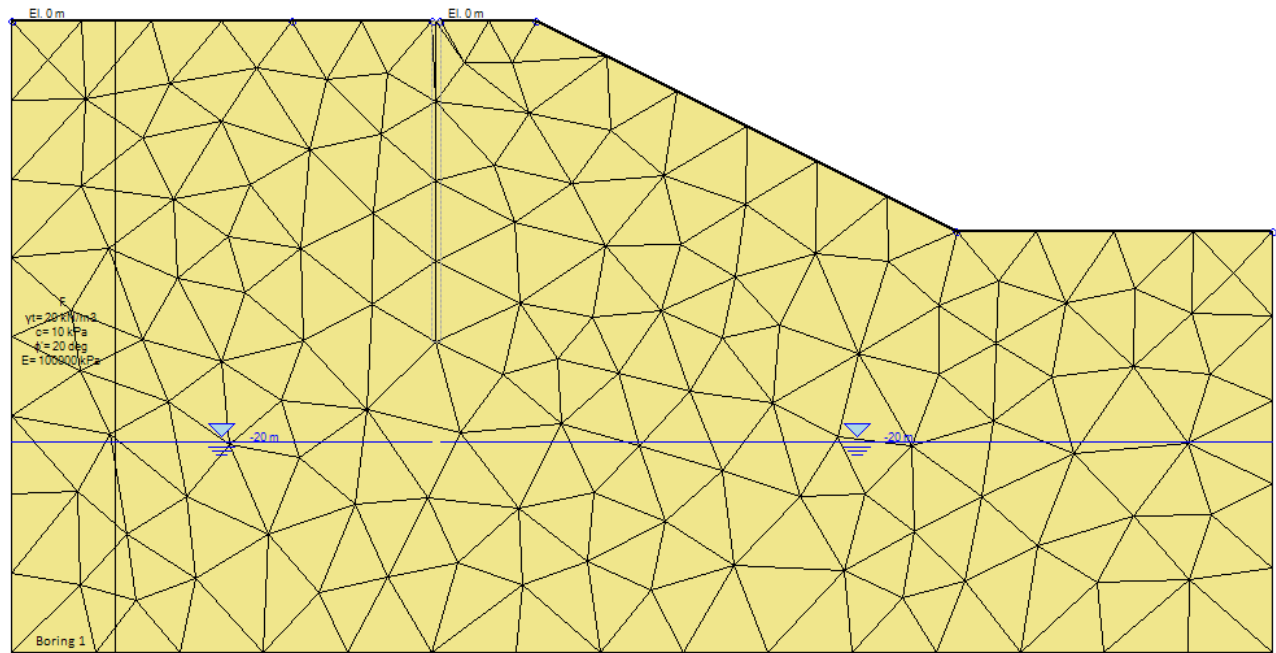

Strength reduction analysis

Example 5: Shear strength reduction analysis example

Design Section Name and General Data

1. Design Section Name
Base model

3. Boundaries / Model Limits
Top 10 m
Left -30 m Right 30 m
Bottom -30 m

5. Wall In-Plane Rotation
Angle in plane from y-y' axis 0 deg
This angle rotates the wall angle from the horizontal y-y' axis. To see the effect, change the angle say 10 degrees and go to View Top-Plan.

6. Excavation shape
Long 2D excavation

OK Cancel

Ground Water Table Stage: 1

Retained Side Water
Elev. 20 m

Water on Excavated Side
 Use general EL -20 m
 Maintain at subgrade
 Dewater below subgrade 5 m
 Dewater on both sides

Groundwater Options
 Hydrostatic
 Simplified flow net
 Full flow net analysis

User defined water pressures Define
 Balanced method

Liner Effect (Advanced)
 Create seal at excavation bottom (See Theory Manual).

Stage
 Apply to all stages
 Apply to one stage Stage 1
 Apply to stages From stage Stage 0 To stage Stage 1

Water density
 g_w 10 kN/m³

OK Cancel

Strength reduction analysis

Example 5: Shear strength reduction analysis example

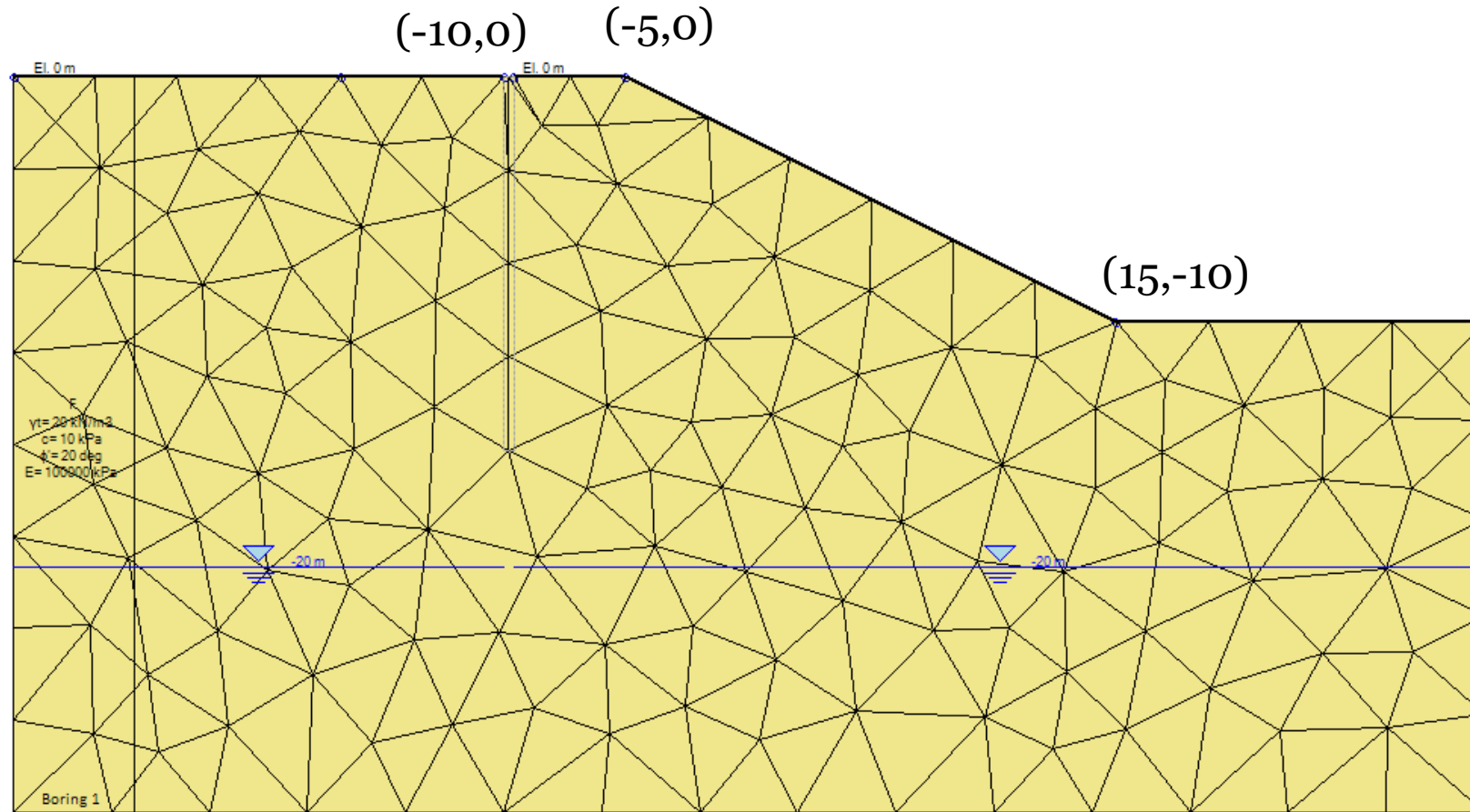

Example 5: Shear strength reduction analysis example

Soil Types

Soil Types

- O1
- O2
- S1
- Clay
- GT
- Rock

1. Name and Basic Soil Type

Soil Name: F Color

Description: Fill

2. Soil Type - Behaviour

Sand Show test data (SPT, CPT, Etc)

Clean fine sands, and slightly silty sands

Not defined

3. Default drained-undrained behavior for clays (See Theory Manual)

Undrained behaviour Drained

A. General C. Elasto-plastic D. Bond E. Adv. F. Piles

4. Unit Weights - Density

γ_t 20 kN/m³ γ_{bulk} 20 kN/m³ γ'_s 10

5. Strength Parameters and Poisson Ratio

Drained strength properties

c' 10 kPa ϕ' 20 degrees

Peak - constant vol. (for estimation)

ϕ_{cv}' Omittec degrees ϕ_{peak}' Omittec degrees

ν 0.3

6. Permeability

K_x 9.999999 m/sec K_z 9.999999 m/sec

8. At-rest coefficients

$KoNC$ 0.658 $nOCR$ 0.5 $Ko = KoNC * (OCR)^{nOCR}$

FEM properties (summary-tools)

Database Database OK Cancel

10.1 Loading Elasticity Paramaters

E_{vc} 100000 kPa exp 0.5 $Pref$ 95.8 kPa α_v 0 α_h 1

10.3 Reloading Elasticity Modulus

$rEur = Eur/Eload$ 3

Tunneling

- Tunnel construction affects existing structures
- Complex soil structure interaction problem
- full numerical analysis essential

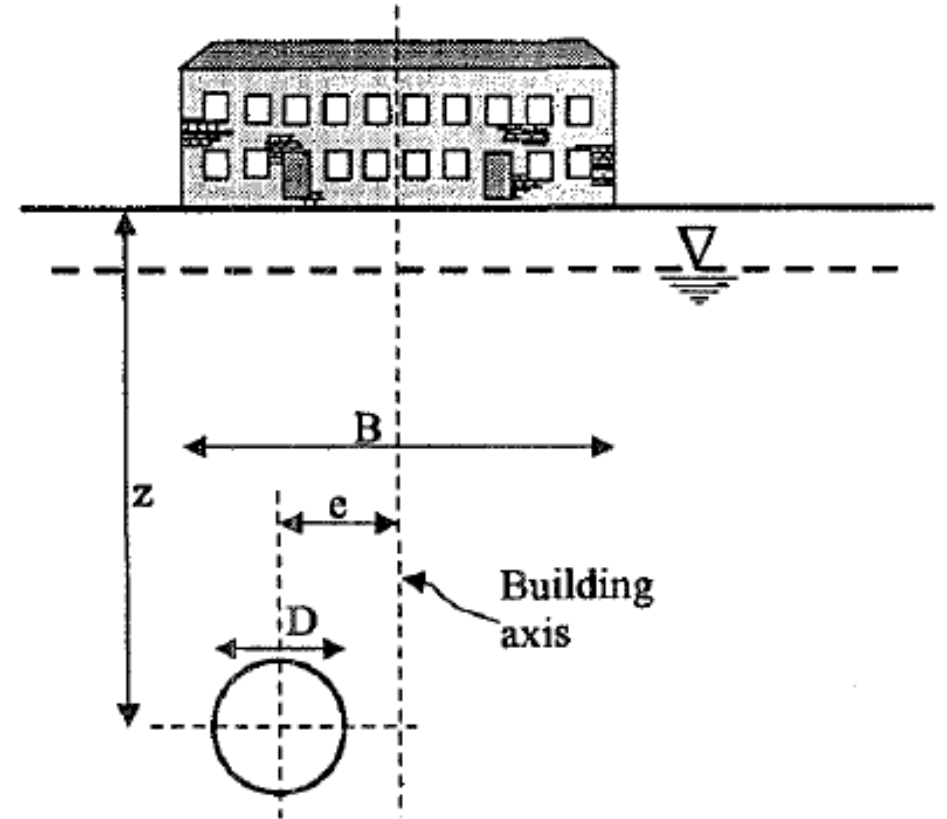

Tunneling

3D load transfer

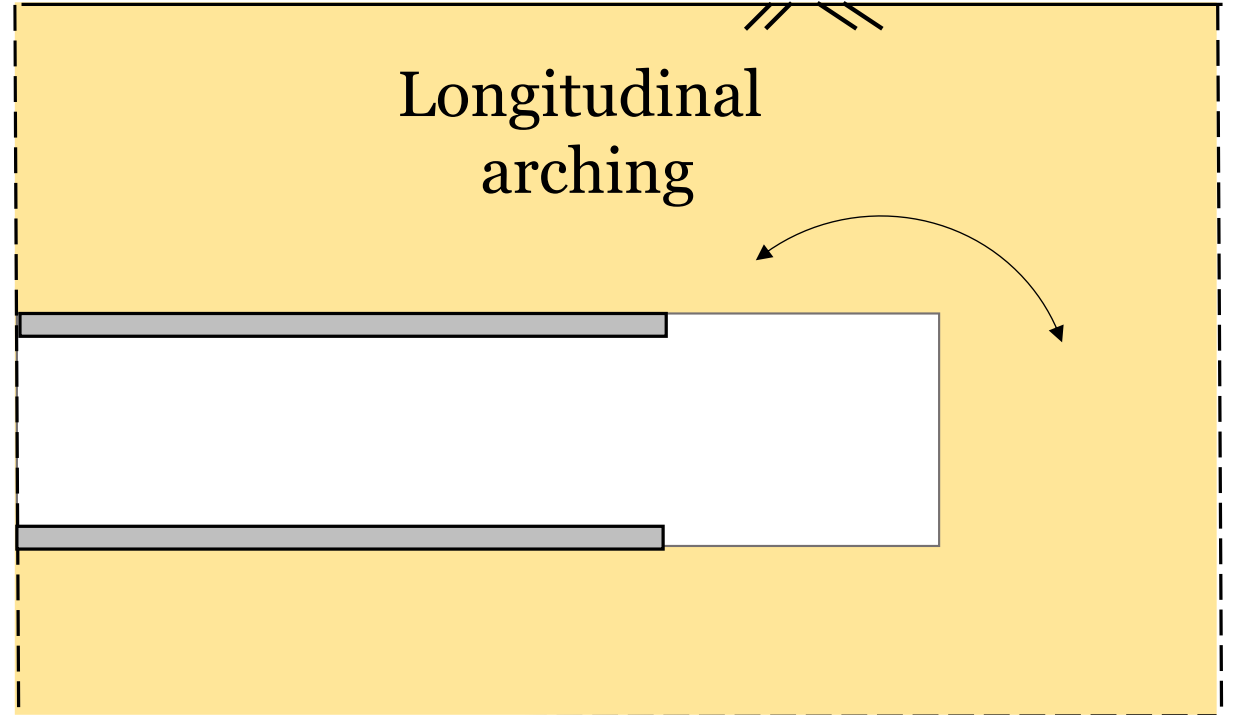
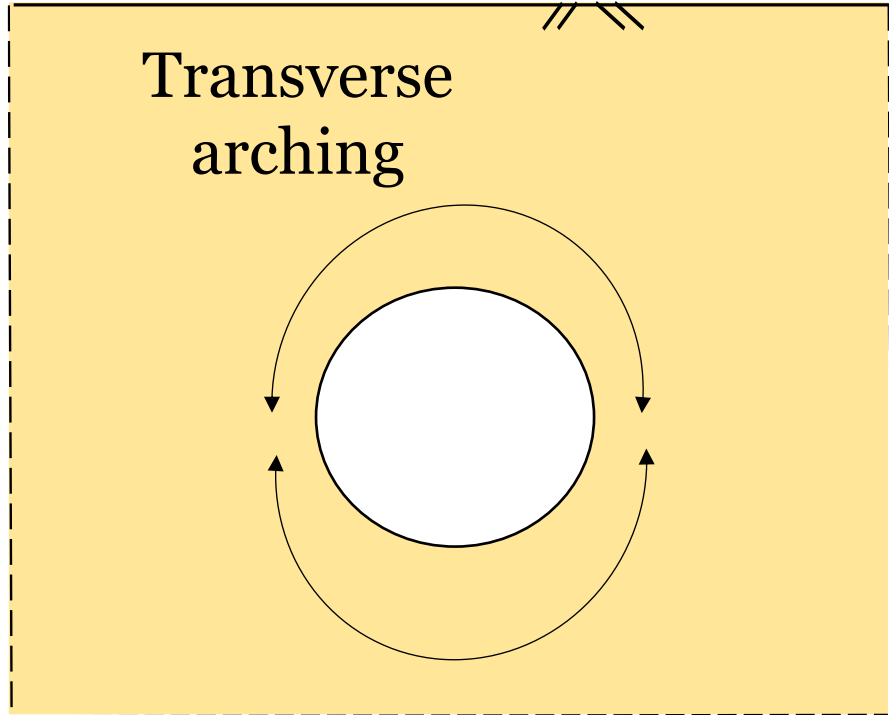

transverse and longitudinal arching around the unsupported section

Tunneling

TBM tunnel construction stages

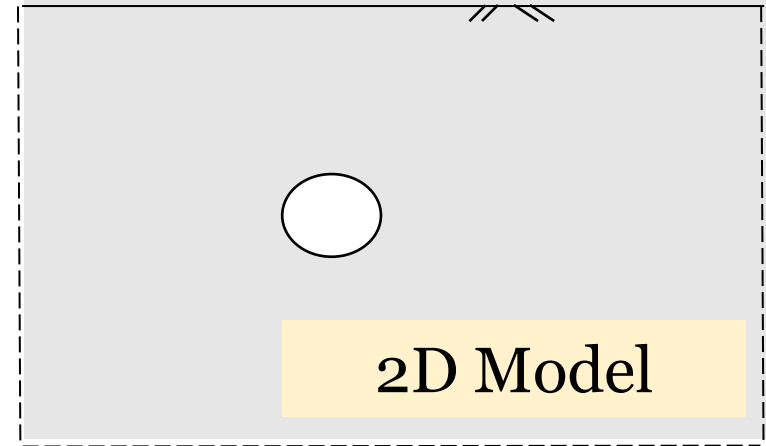
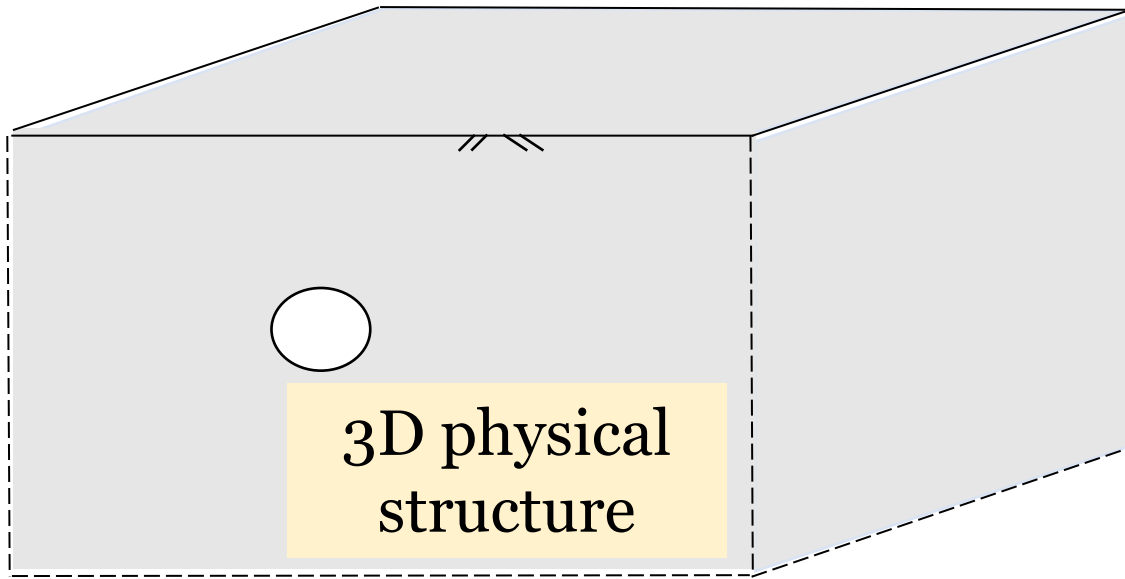

When modelling in plane strain something must be prescribed,
rather than predicted.

Tunneling

The volume loss control method (contraction)

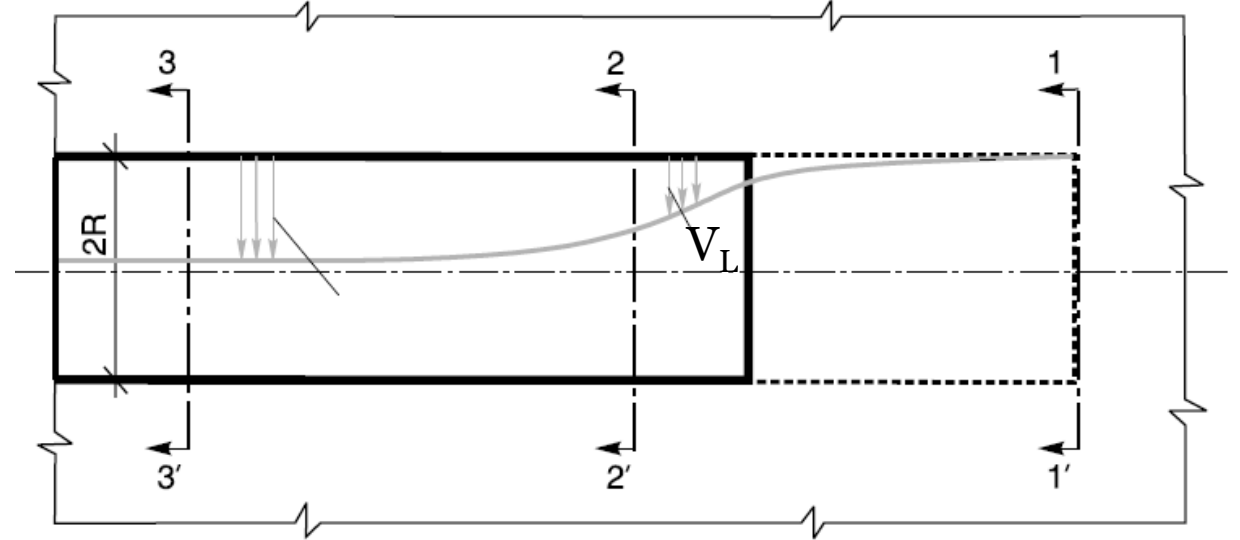
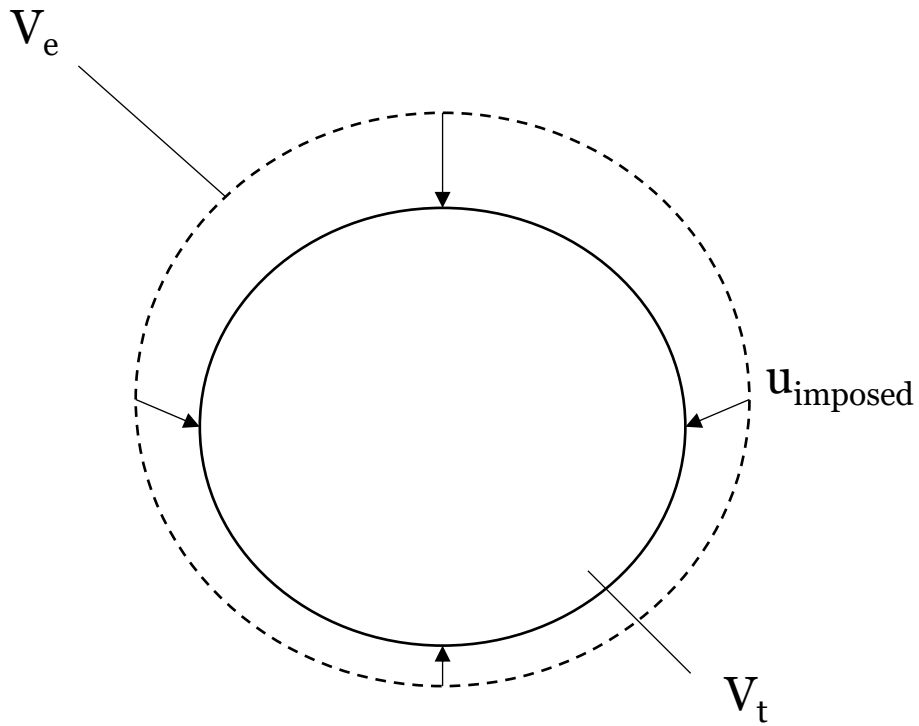

Displacement based contraction:

$$V_L = V_e - V_t$$

V_e : excavated tunnel volume

V_t : final tunnel volume

Tunneling

Indication of volume loss values

Table 7-7 Relationship between Volumes Loss and Construction Practice and Ground Conditions

Case	V_L (%)
Good practice in firm ground; tight control of face pressure within closed face machine in slowly raveling or squeezing ground	0.5
Usual practice with closed face machine in slowly raveling or squeezing ground	1.0
Poor practice with closed face in raveling ground	2
Poor practice with closed face machine in poor (fast raveling) ground	3
Poor practice with little face control in running ground	4.0 or more

Tunneling

Example 6: TBM constructed tunnel

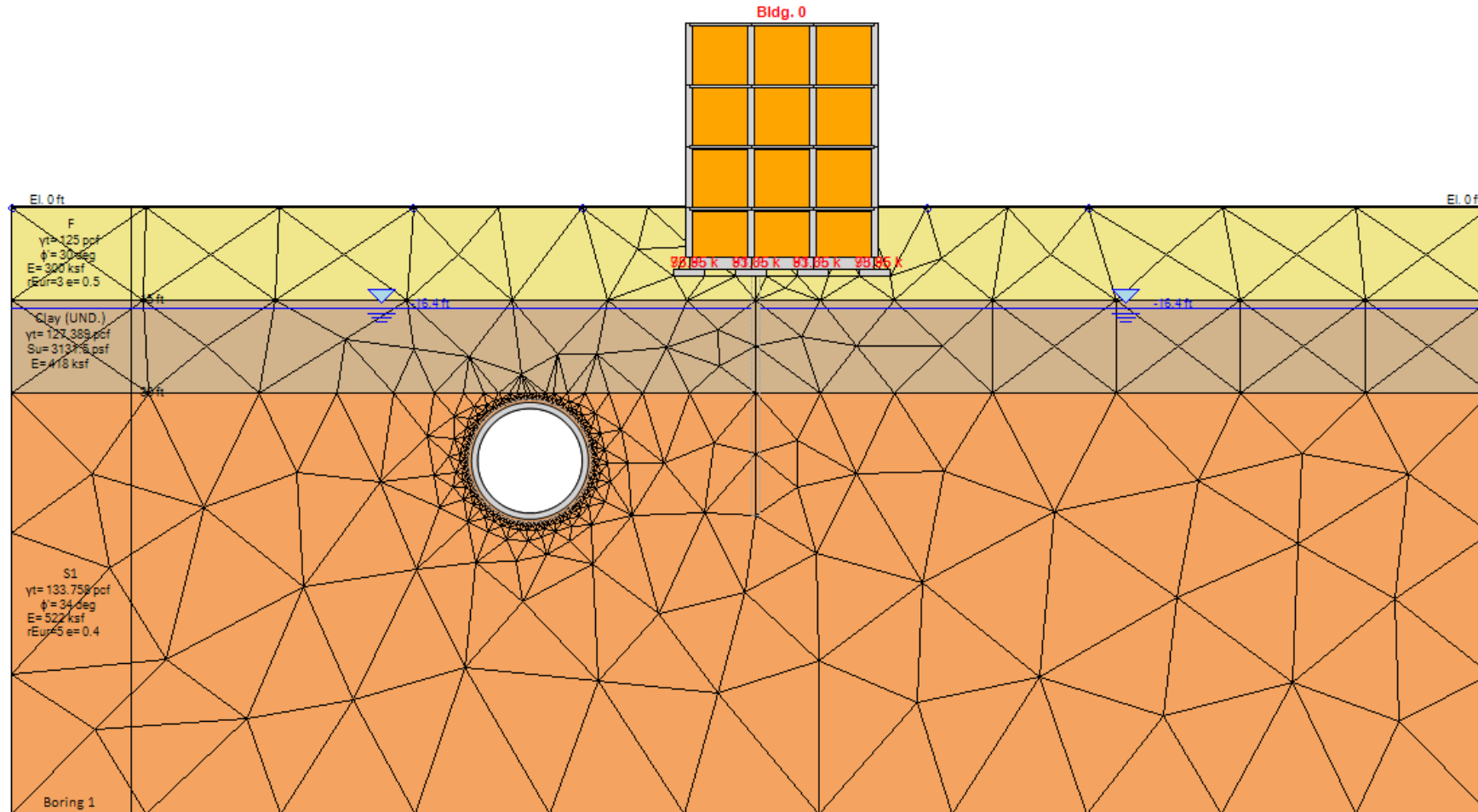

Tunneling

Example 6: TBM constructed tunnel

Stage 0 : greenfield conditions

Stage 1: building structure (conditions prior to tunnel construction)

Stage 2: excavation of tunnel and TBM activation

Stage 3: contraction (1 %)

Stage 4: grouting stage (3.5 ksf)

Stage 5: concrete lining installation

Tunneling

λ method (Partial deactivation of soil)

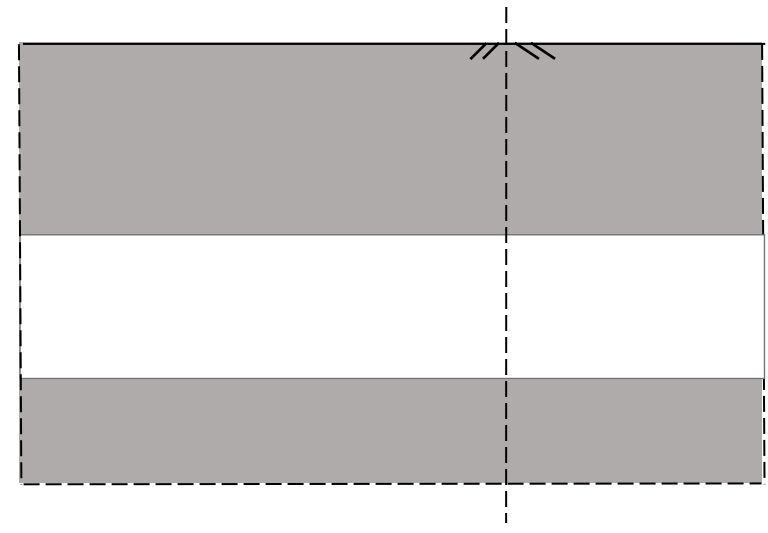
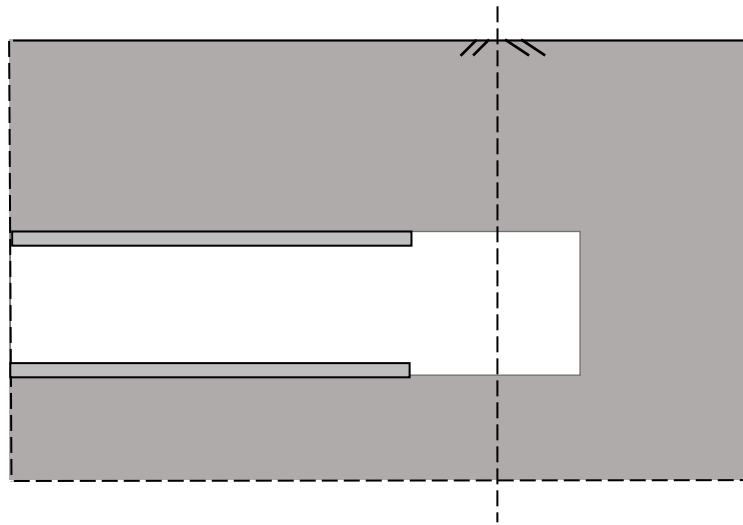
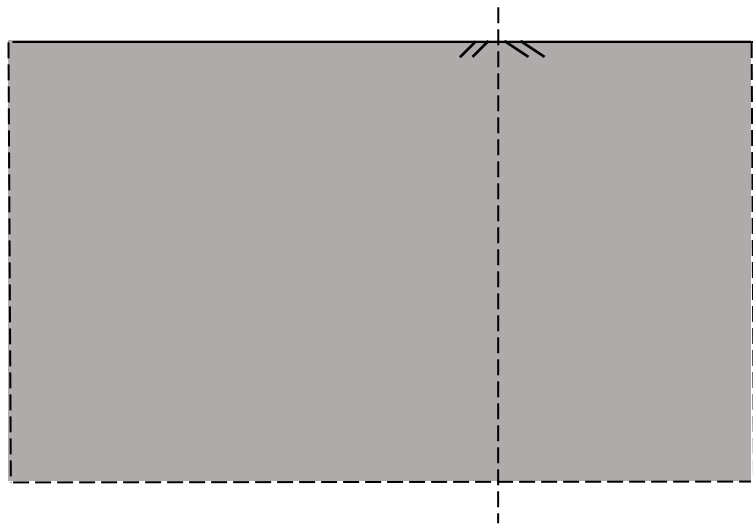
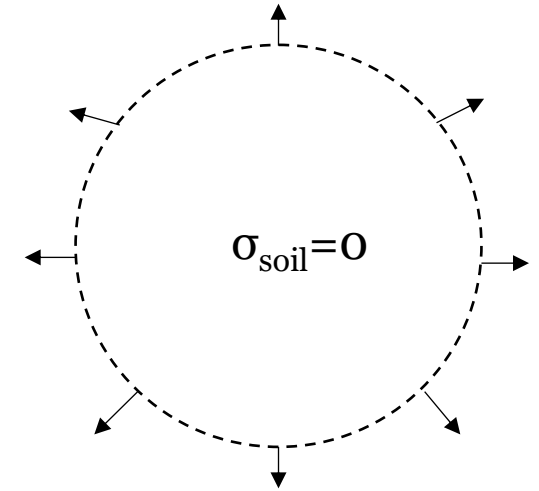
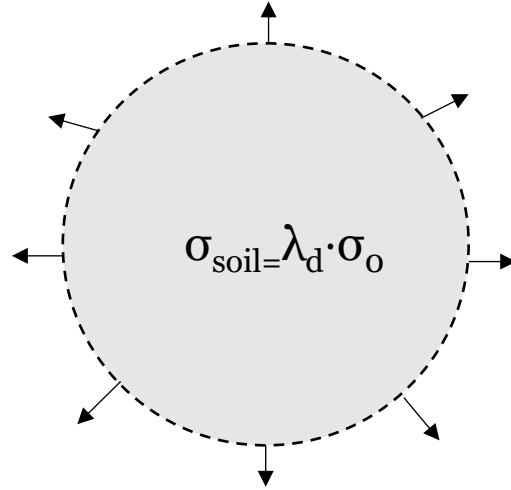
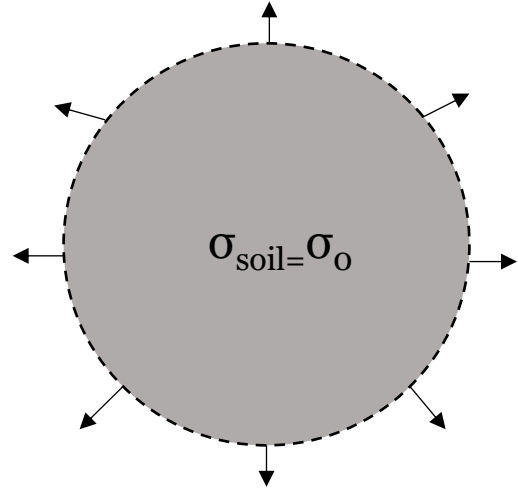

Prior to excavation

Tunnel excavation stage

Plain strain excavation

Tunneling

Example 7: SEM constructed tunnel

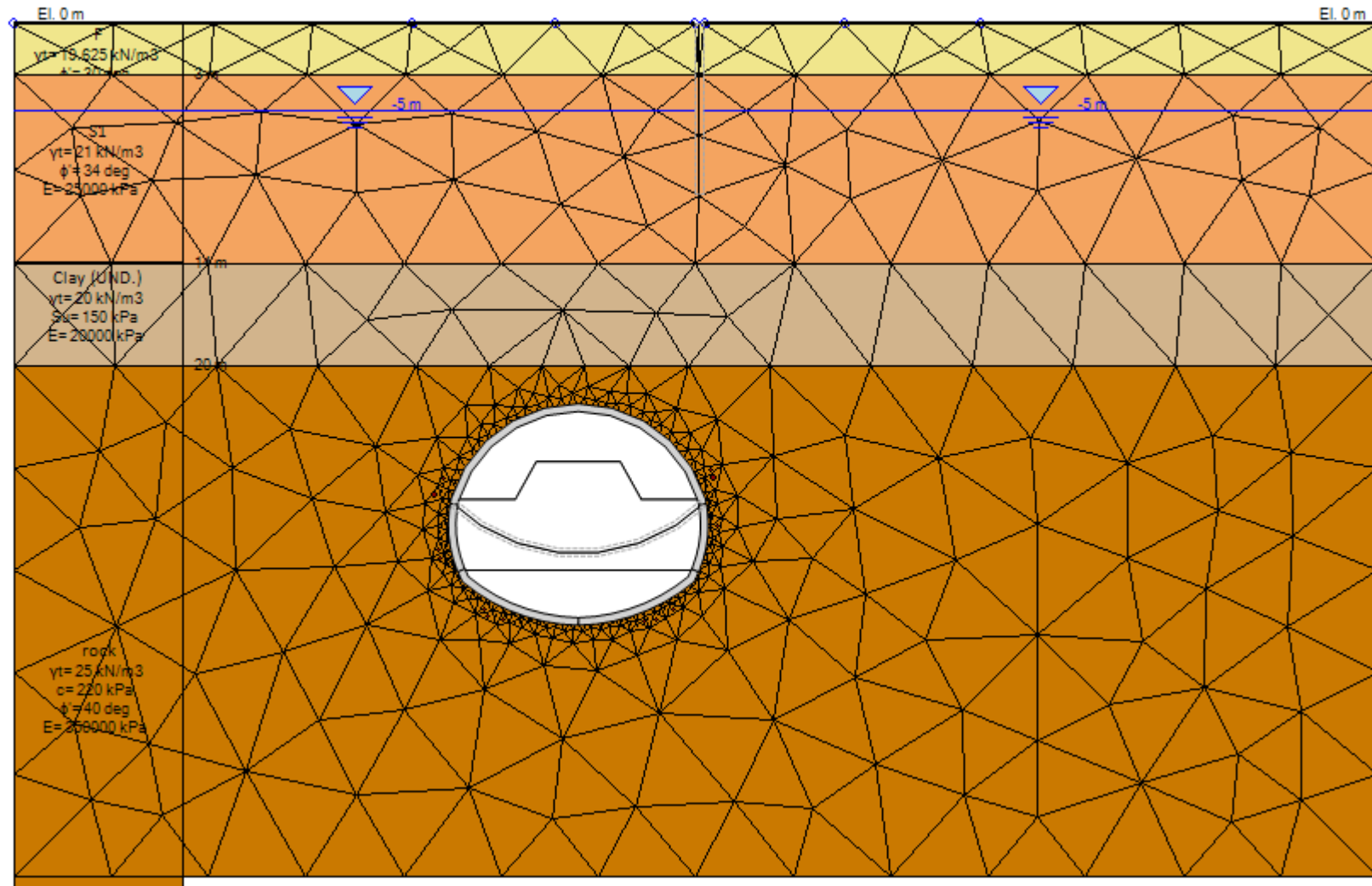

Tunneling

Example 7: SEM constructed tunnel

Stage 0: green field conditions.

Stage 1: excavation of the upper part of the top heading (partial 20%)

Stage 2: the tunnel crown is supported

Stage 3: Excavation of the support core (partial 20%)

Stage 4: A temporary lining is constructed at the bottom of the so far excavated section.

Stage 5: full excavation of top heading 100%

Stage 6: excavation of the bench part of the tunnel section (partial 20%)

Stage 7: construction of the remaining lining sections (left, right wall and invert)

Stage 8: full excavation of remaining tunnel 100%

Seismic design

Novak Boundaries

Fundamental Solution
of wave equation in
infinite disc:

$$\rho \frac{\partial^2 u}{\partial t^2} = (\lambda + \mu) \frac{\partial \bar{\epsilon}}{\partial x} + \mu \nabla^2 u$$

$$\rho \frac{\partial^2 v}{\partial t^2} = (\lambda + \mu) \frac{\partial \bar{\epsilon}}{\partial y} + \mu \nabla^2 v$$

$$\rho \frac{\partial^2 w}{\partial t^2} = (\lambda + \mu) \frac{\partial \bar{\epsilon}}{\partial z} + \mu \nabla^2 w$$

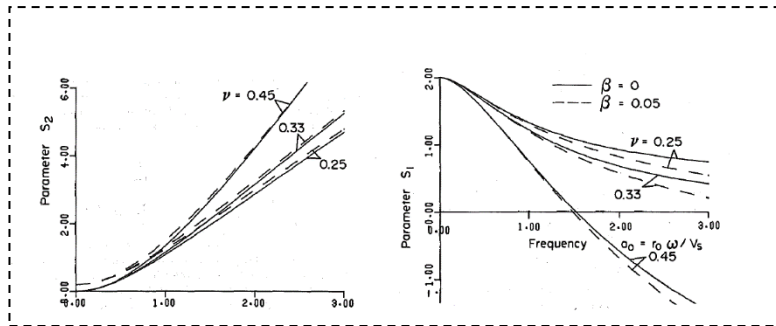
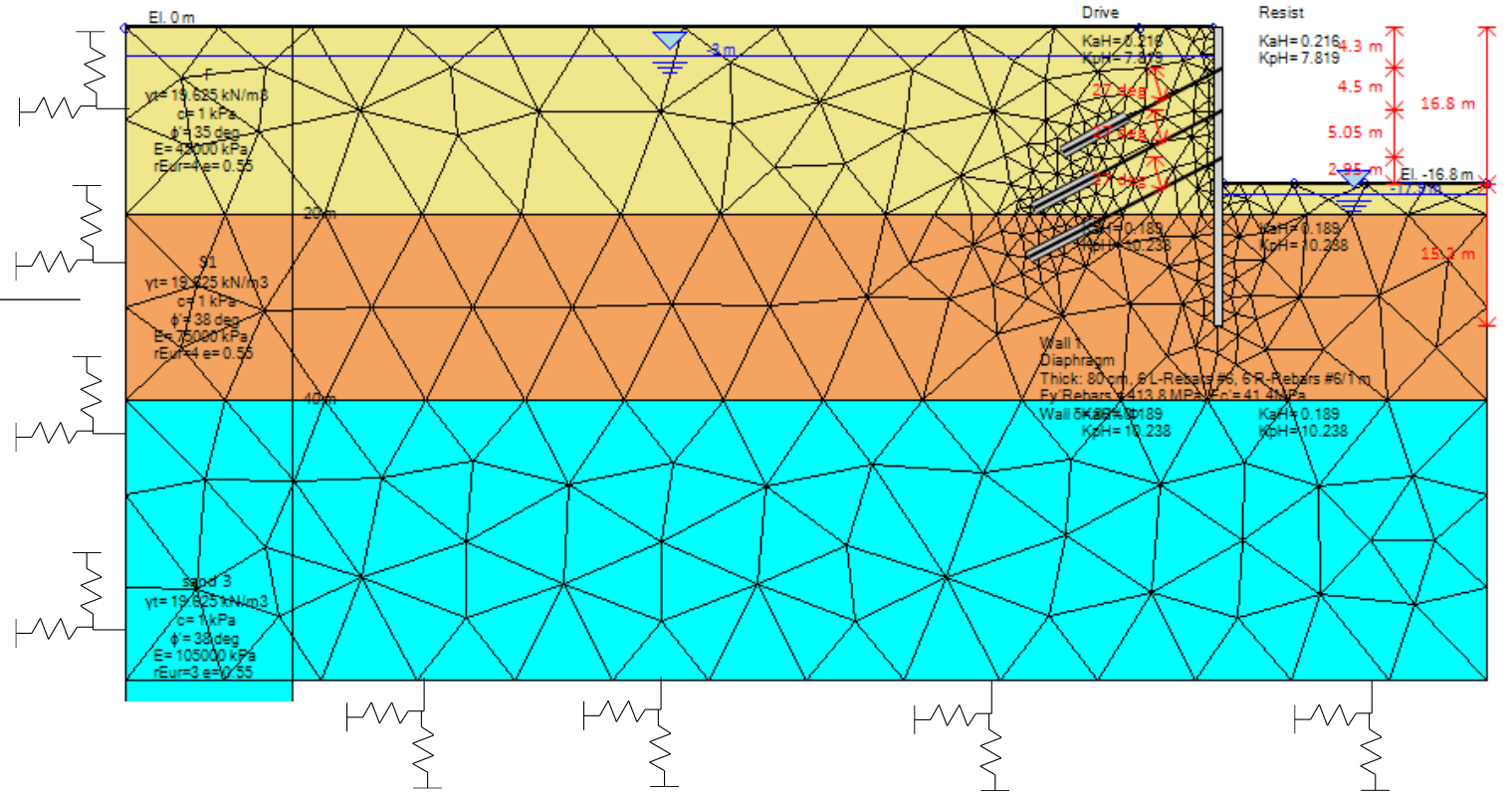

Seismic design

Example 8: Earthquake design

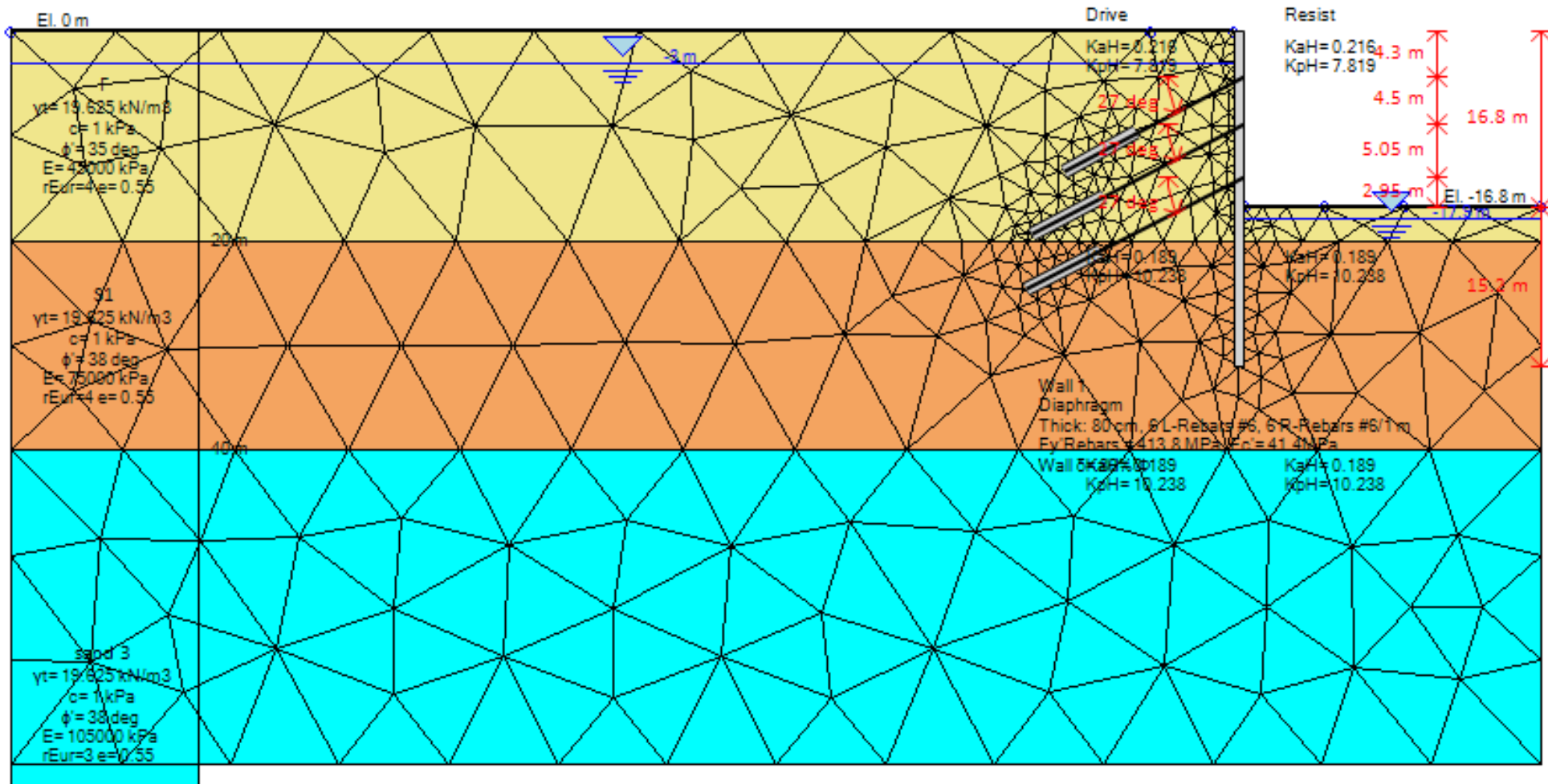

Seismic design

Calculation of design acceleration

- The user can directly prescribe the design acceleration
- Use bedrock acceleration and factors to generate a_{df}

Seismic code	Occupancy category		
	Higher	Moderate	Lower
IS 1893-Part1	1.5	1.2	1.0
Canadian Building Code Act	1.5	—	1.0
BS EN 1998-1	1.5	—	0.8
ASCE/SEI 7	1.5	1.25	1.0
NZS 1170 Part 5	1.3	—	0.6
NBC 105	2.0	1.5	1.0
EAK 2000	1.3	—	0.85
Iranian Standard 2800	1.2/1.4	1.0	0.8

2.b Base Acceleration and Site Effects

Base Acceleration
AxBASE= 0.37 g

Site Soil Response
Factor S_s= 1 >

Topographic Site
Response S_t= 1 >

Importance Factor I= 1 >

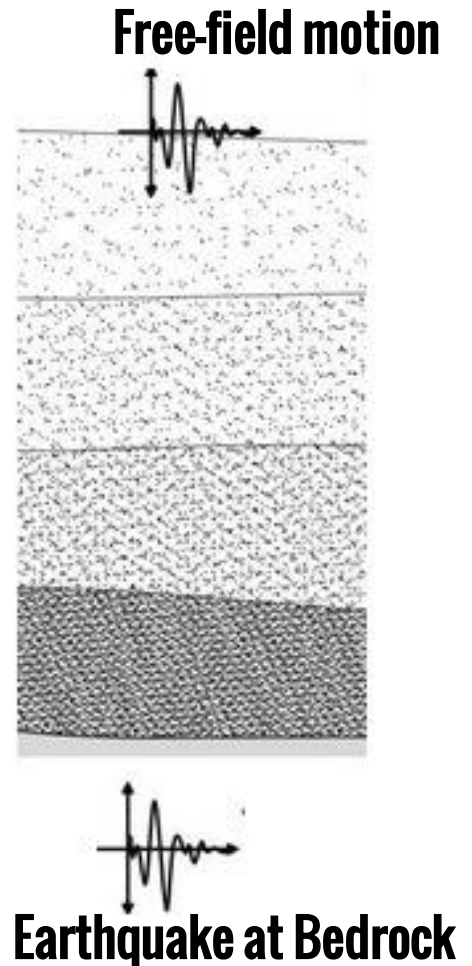

Seismic design

Calculation of Response R factor

- Rigid walls experience greater forces compared to yielding walls

Table 7.1 — Values of factor r for the calculation of the horizontal seismic coefficient

Type of retaining structure	r
Free gravity walls that can accept a displacement up to $d_r = 300 \alpha \cdot S$ (mm)	2
Free gravity walls that can accept a displacement up to $d_r = 200 \alpha \cdot S$ (mm)	1,5
Flexural reinforced concrete walls, anchored or braced walls, reinforced concrete walls founded on vertical piles, restrained basement walls and bridge abutments	1

Eurocode EC8

3. Wall Behavior and Response R factor

3.a Basic Wall Behavior

Flexible Rigid (Wood Method)

3.b. Flexible Wall Behavior - R calculations

R= User R according to Richards Elms

R according to Building Code R according to Liao Whitman

3.c Specific R method options

3.c.1: R value (Structure Response)

R= >

Seismic design

Mononobe-Okabe :

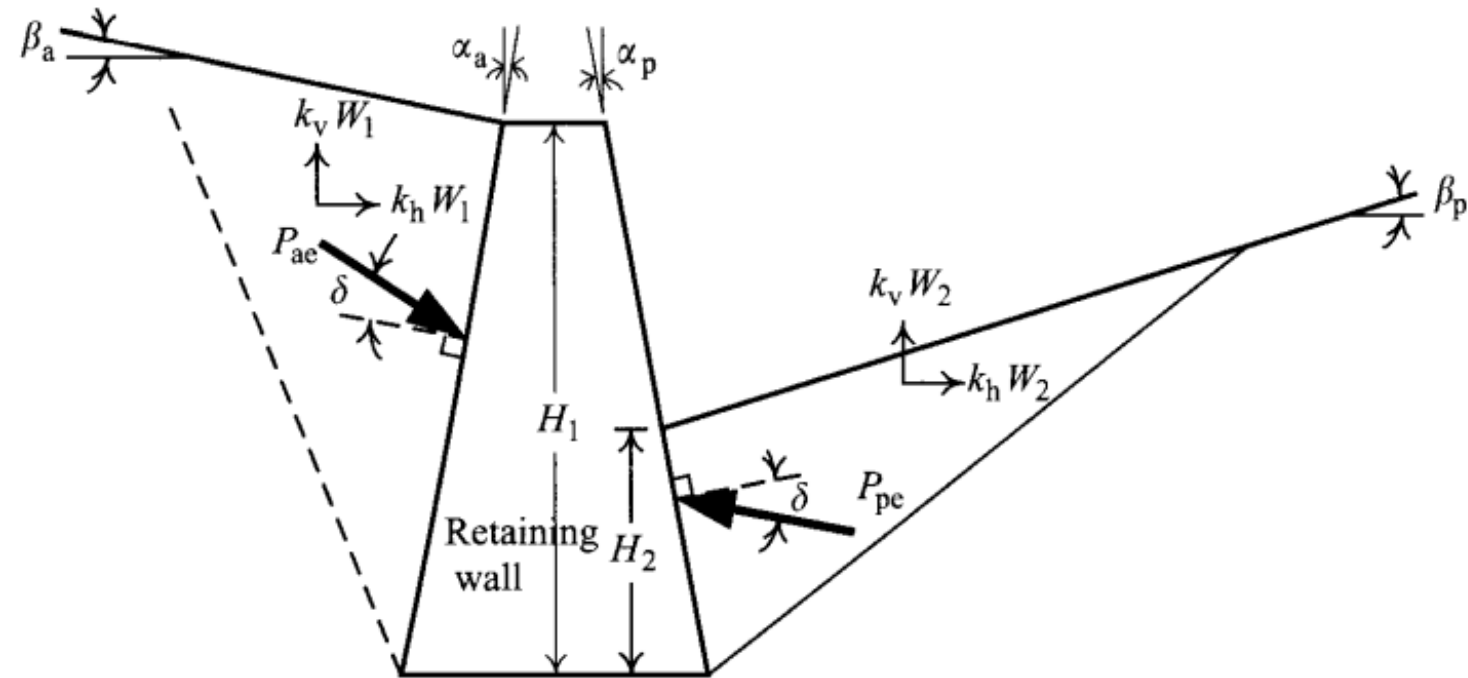

W_1 : Weight of wedge in the active zone

W_2 : Weight of wedge in the passive zone

5. Deep Excavation FEM Cases

- Collapse case
- Measured deflections



6.1 Deep excavation collapse



6.1.2 Deep Excavation Collapse

Mischaracterization of soil properties during investigation

6.1.3 Conventional Analysis

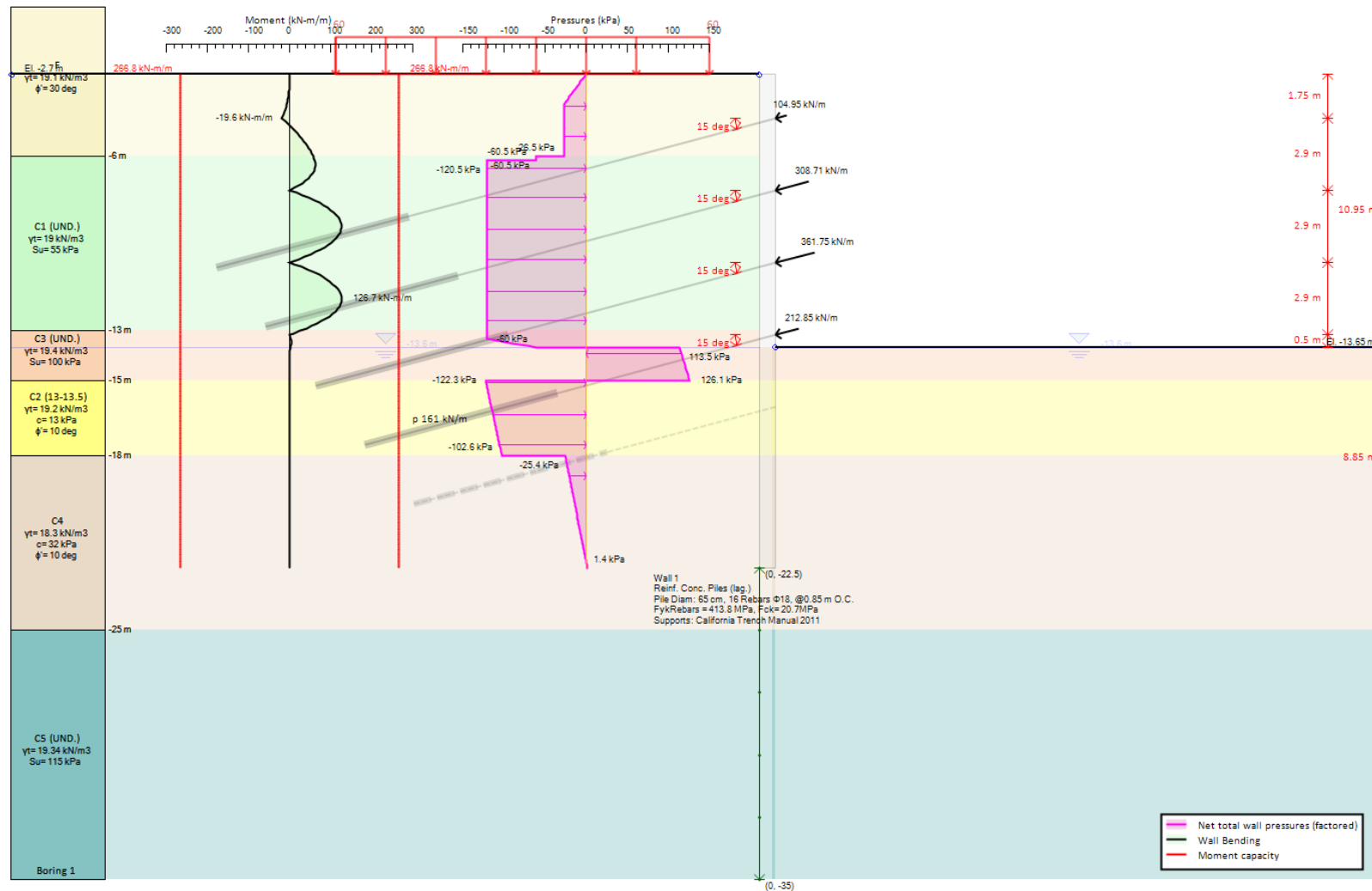

6.1.4 Non-linear analysis

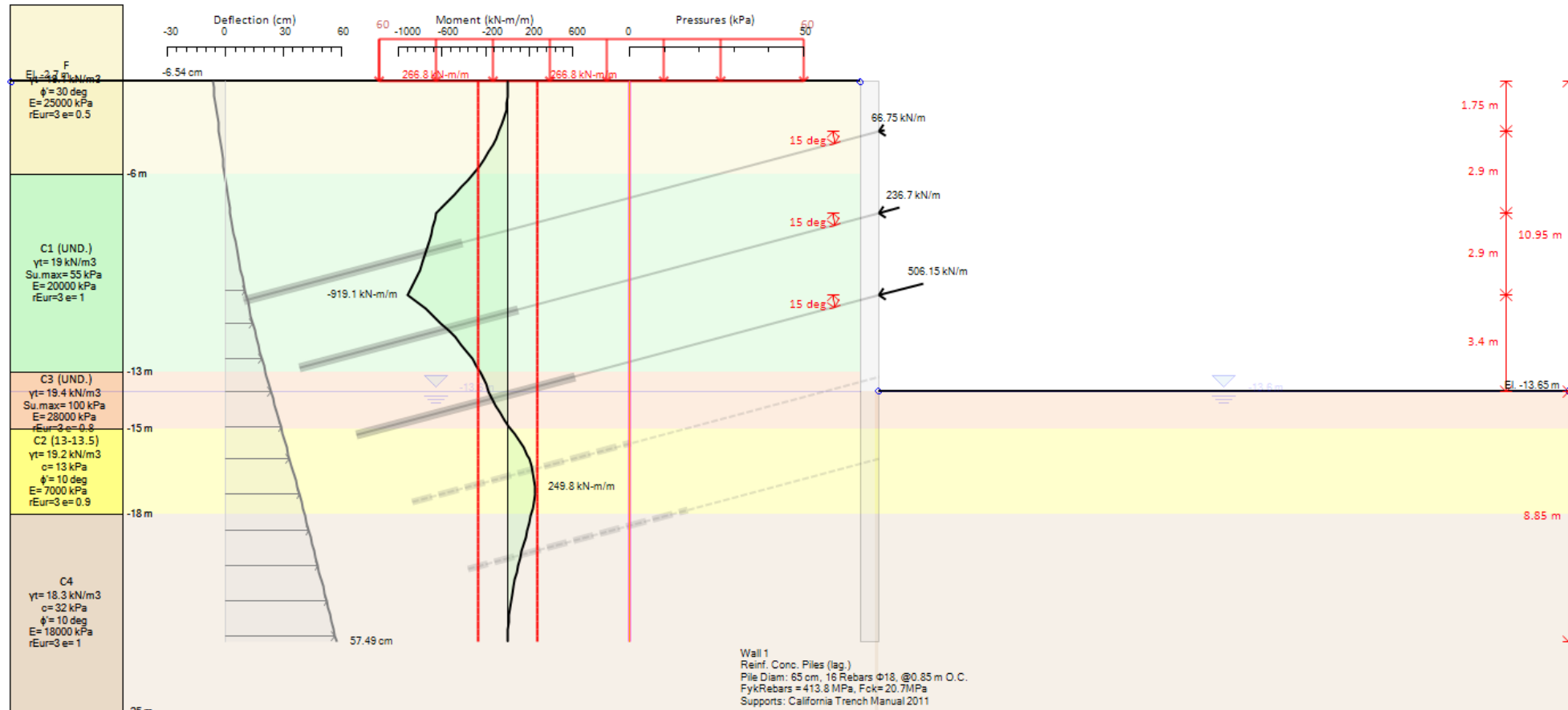

6.1.4 FEM Analysis

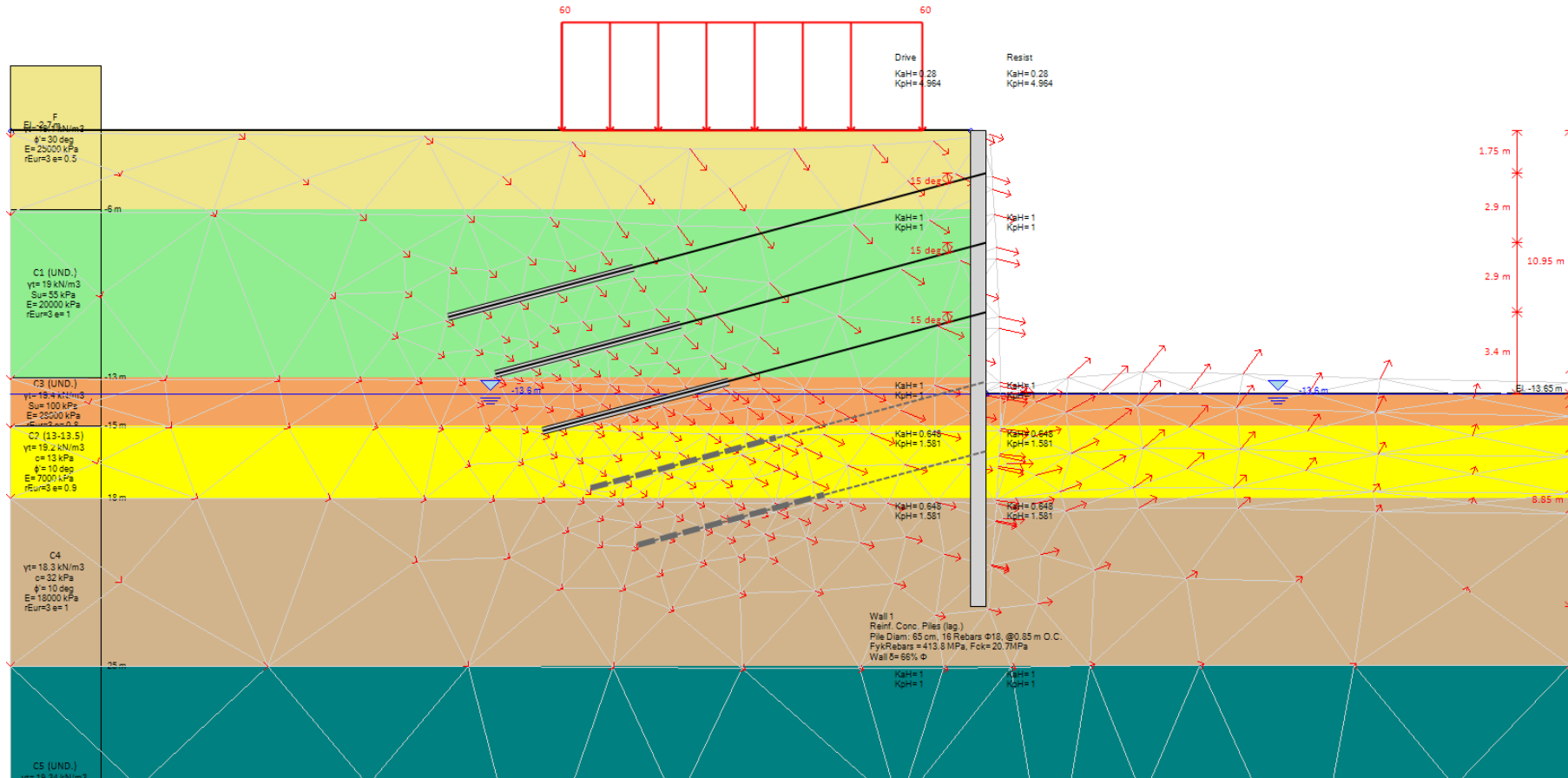

6.2.1 Excavation with LEM/NL/FEM

- 17.7m deep excavation in Taiwan
- Published case history
- 1cm of lateral displacement
- FEM Calibration with MC Model
- Water table at 10.0m

Ground layer description	N	γ_i	Total stress		Effective stress	
			c	ϕ	c'	ϕ
Bottom depth of each layer	value	kN/m ³	kPa	°	kPa	°
1 The backfill layer gradually changed to yellowish brown clayey silt and silty sand mottled with gray including some gravel. Average thickness 4.0 m	1.5-19 (5)	19.3	* 9.8	* 21	0	30
2 The coarse gravel layer comprised yellowish brown coarse, medium, and fine silty sand. Average thickness 11.7 m	15 to > 50 (40)	21.6	—	—	* 4.9	* 38
3 The gravel layer comprised yellowish brown and gray coarse, medium, and fine silty sand. Average thickness 4.6 m	20-58 (35)	21.1	—	—	* 0	* 38
4 The composition of this layer was gray sand and clayey silt containing thin layers of sand and clay Average thickness 4.1 m	12-26 (16)	19.4	9.8	24	0	32
5 The coarse gravel layer comprised yellowish brown coarse, medium, and fine silty sand. Average thickness 10.0 m, hole bottom	> 50 (50)	* 22.1	—	—	* 9.8	* 40

6.2.2 LEM Methods

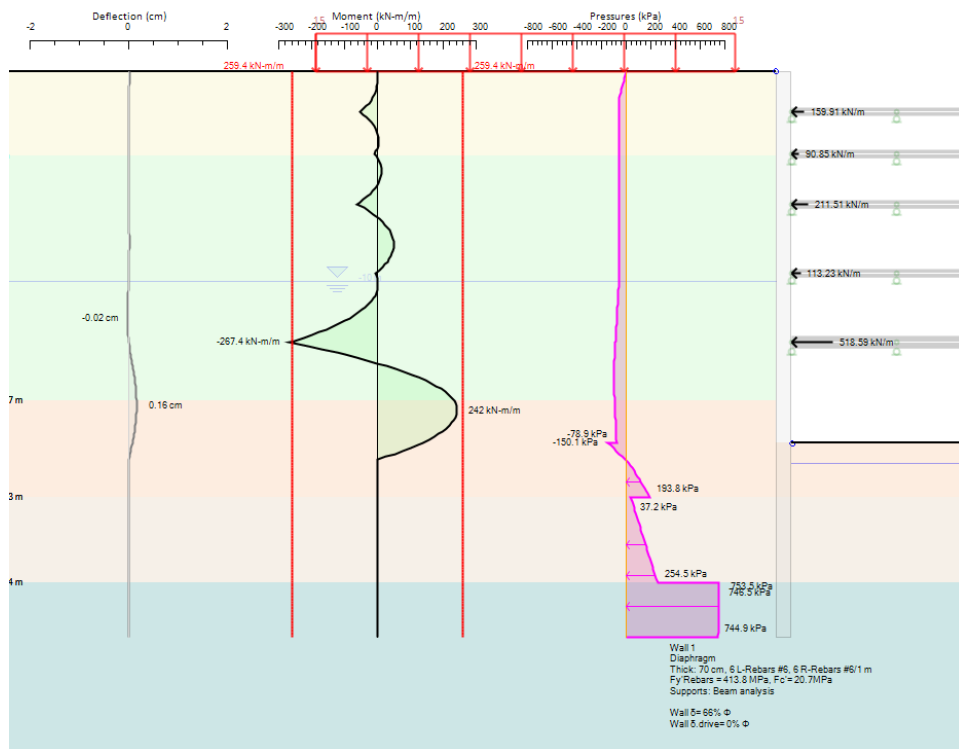

FHWA-Blum's

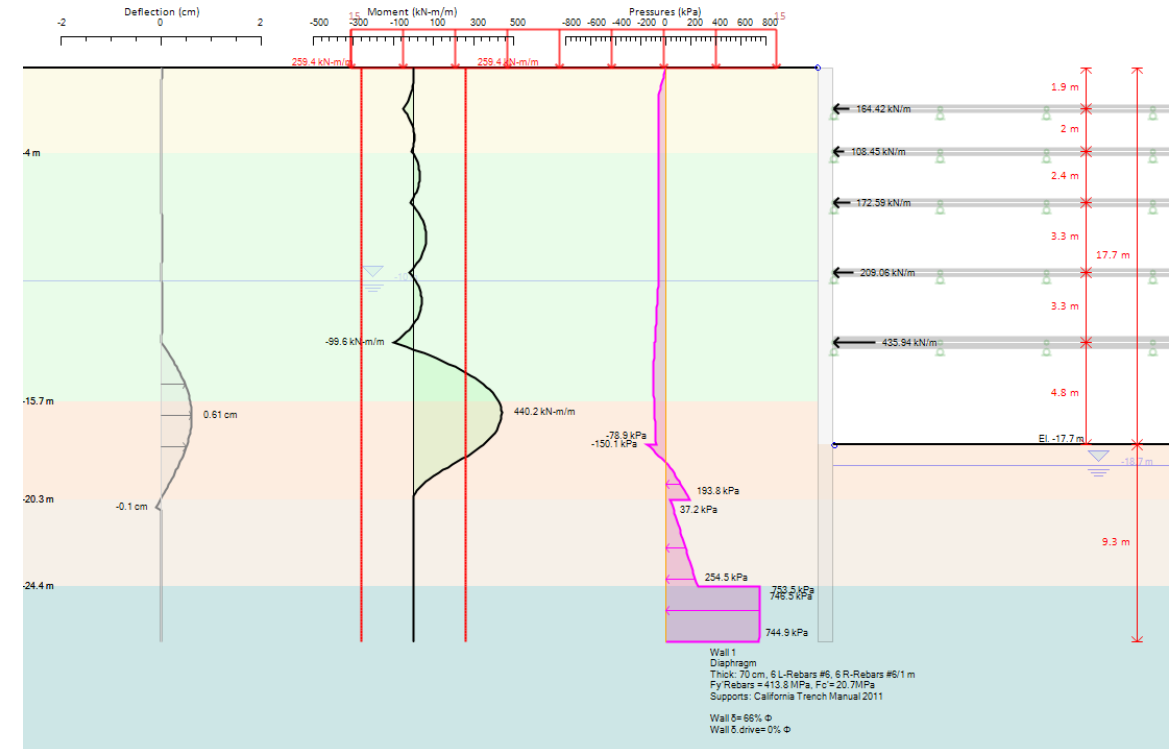

FHWA-CALTRANS

6.2.3 NL Analysis

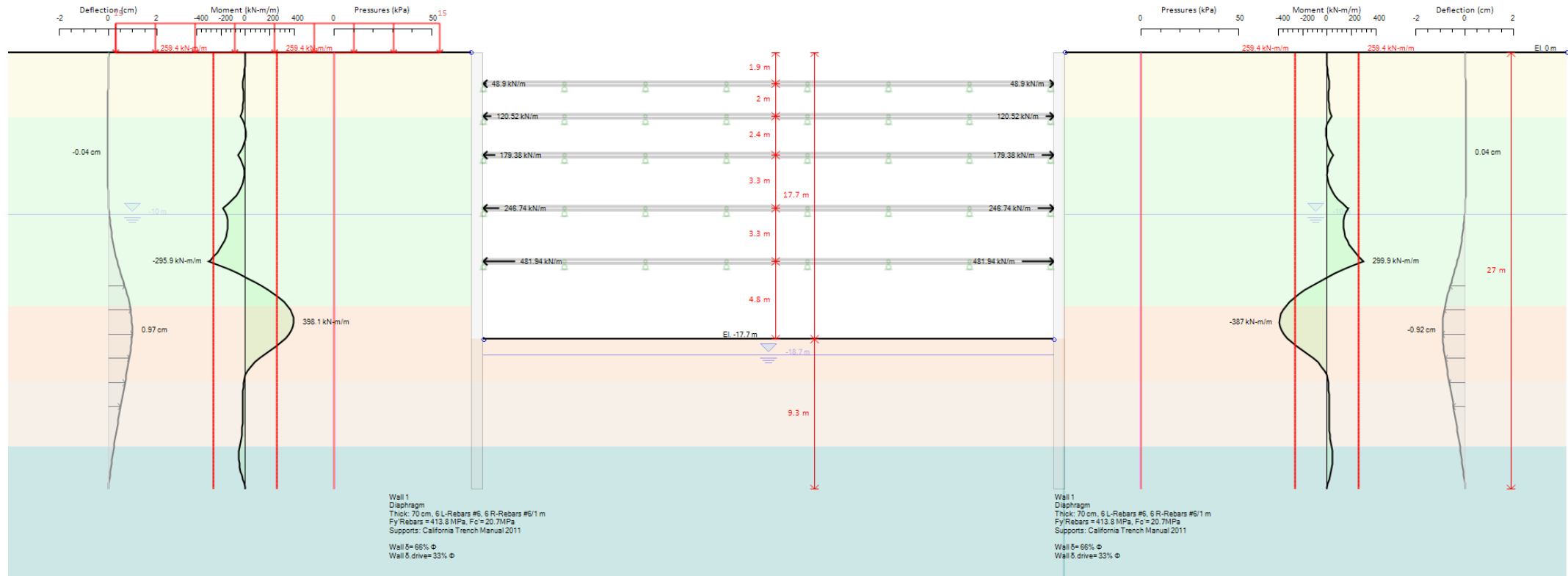

6.2.4 FEM with MC Model

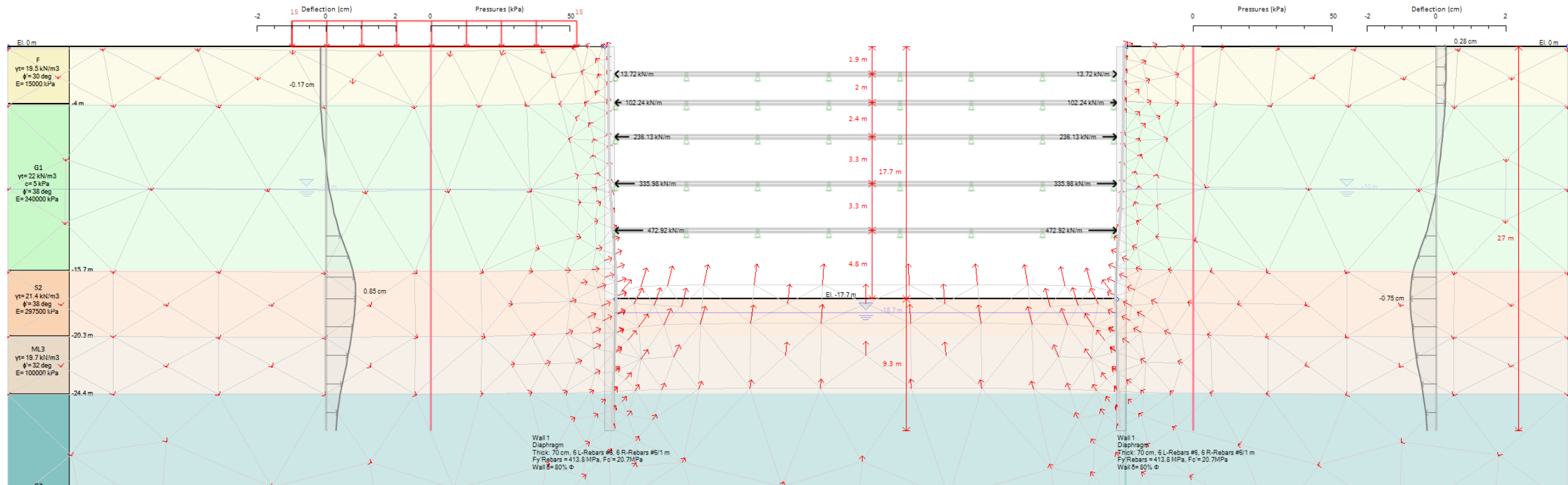

6.2.5 NL Model with EXP Soil Models

- Use SPT Estimate for wall displacement
- Randolph sand (least conservative Eq. most adequate)

Estimate Loading Soil Modulus from SPT Test

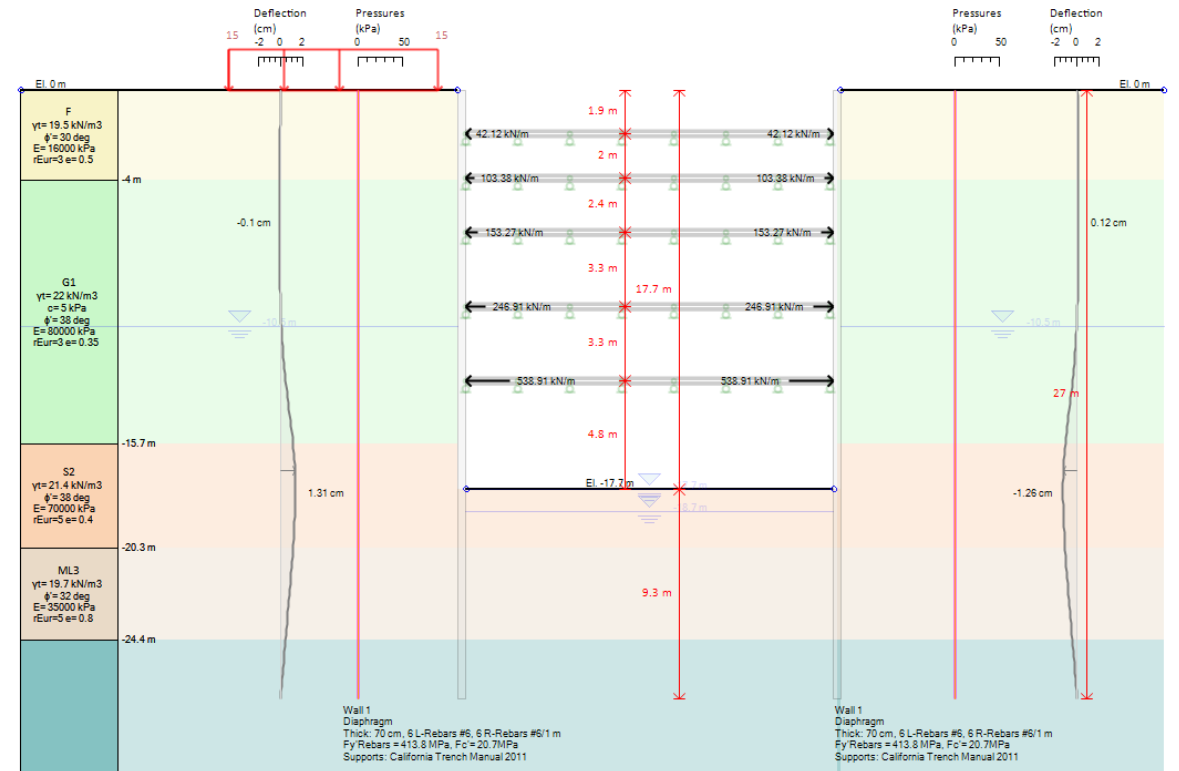
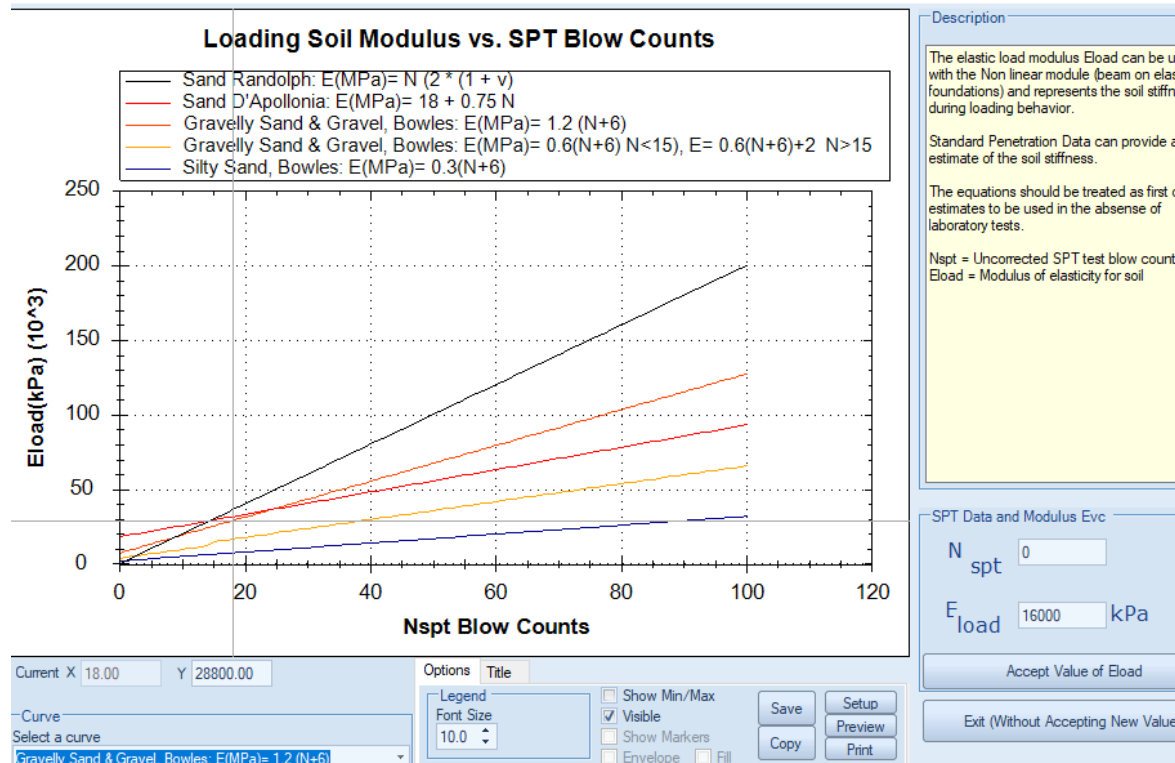

6.2.6 FEM Model with HS Randolph E Estimate

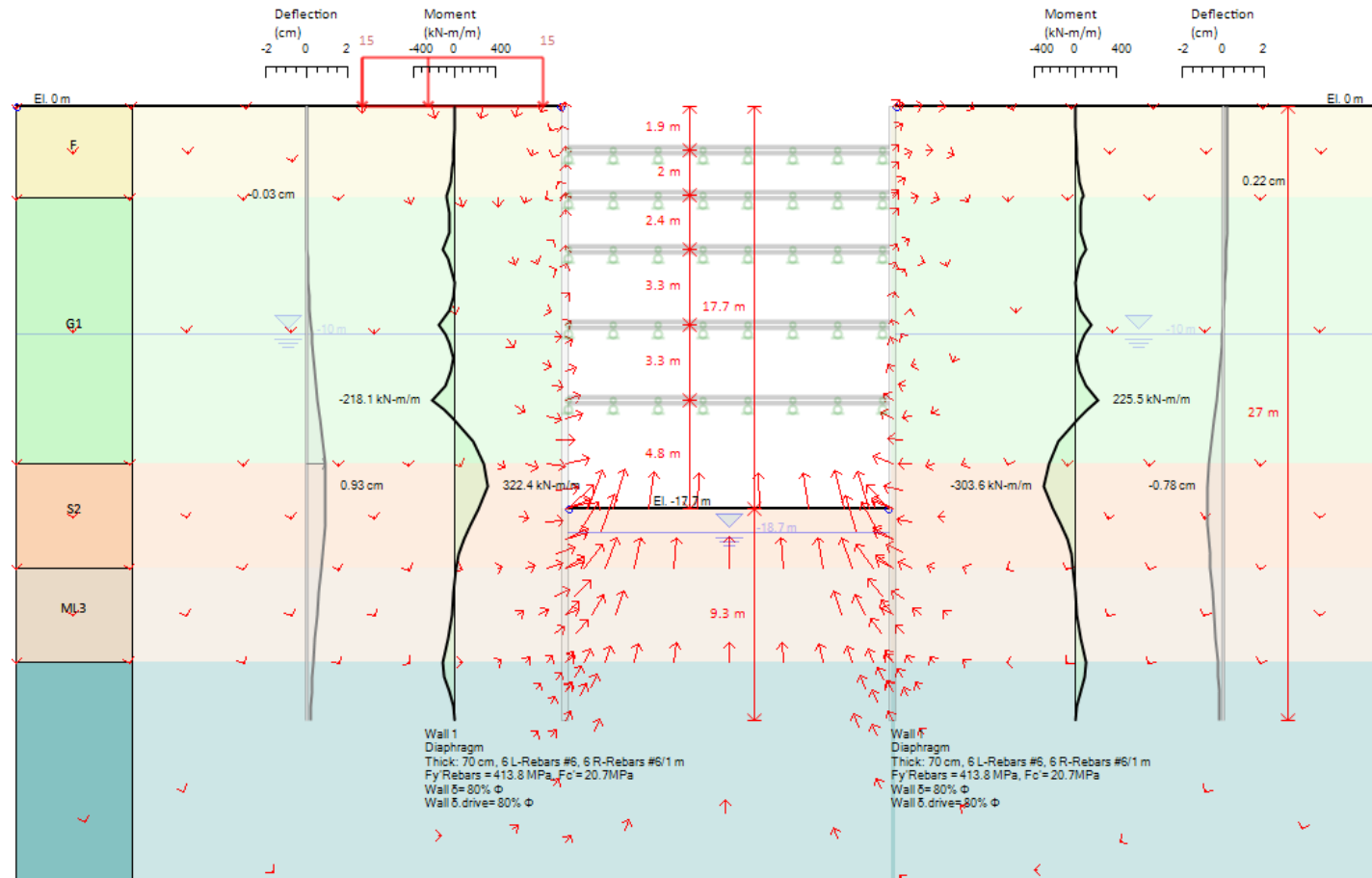

6.2.6 FEM and NL Model with Bowles Gravel E

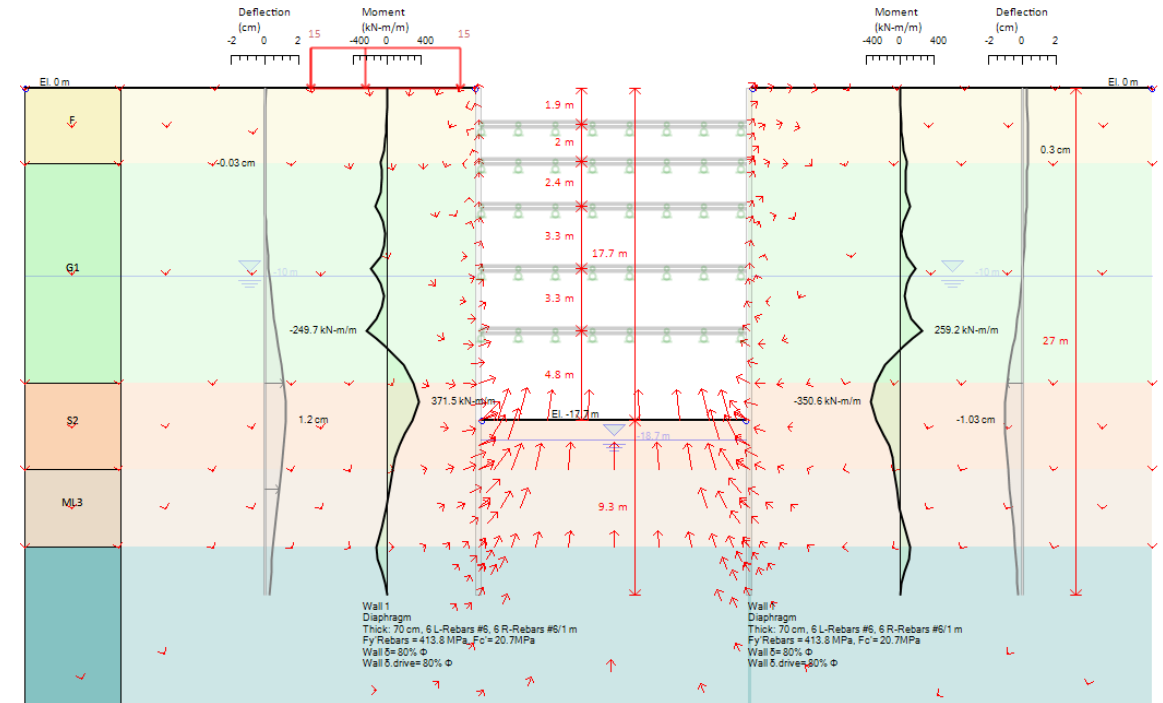
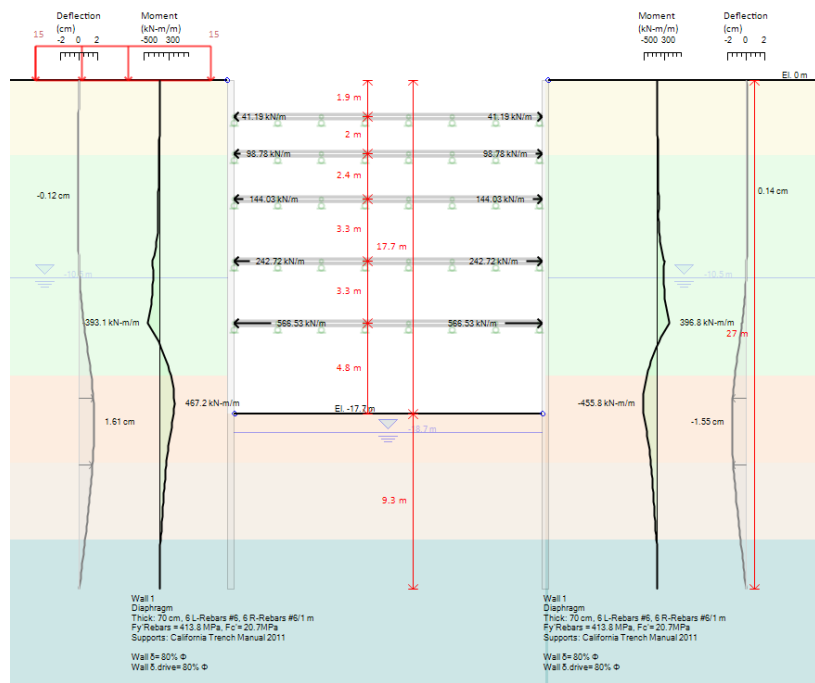

5.27 Influence of Water Modeling in NL Analysis Flownet vs. 1D

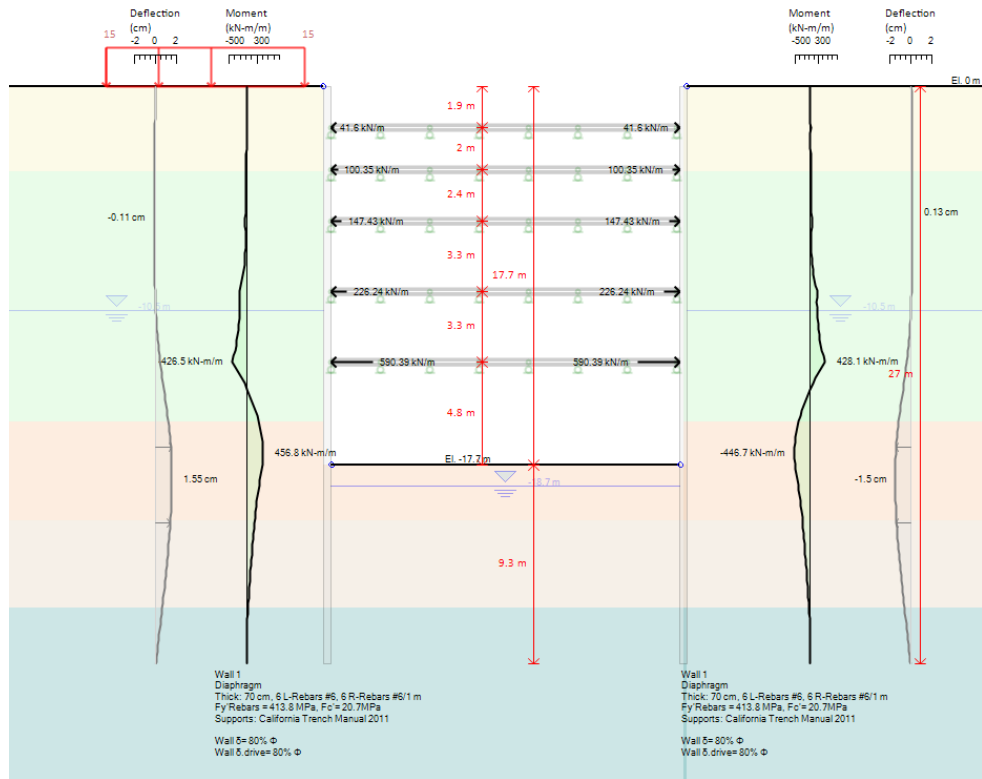

Flownet (2D)

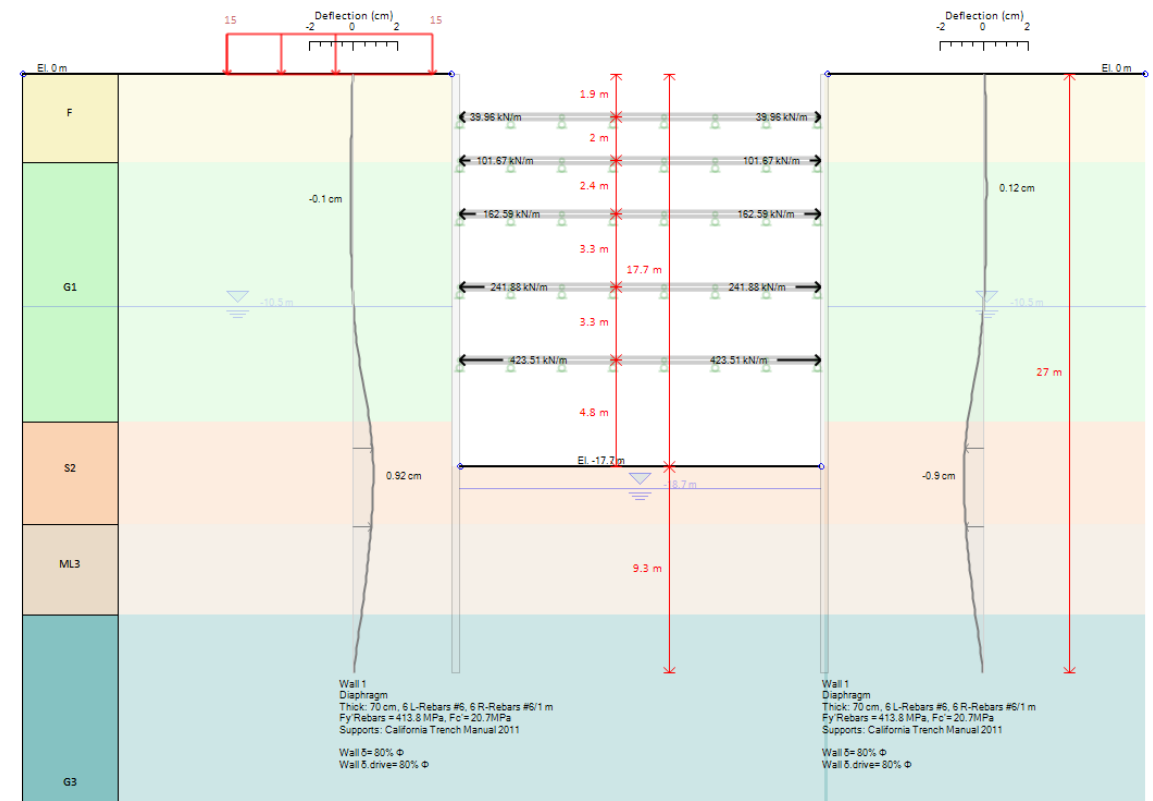

Simplified flow (1D)



6. Marine Issues - Corrosion

Courtesy of JKMC UK
info@jkmc.co.uk

On the bright side it is providing water pressure relief on the backside

7.1.1 Steel sheet piling corrosion

- Sacrificial thickness
- Marine steel grade ASTM A690
- Higher yield steel to extend life
- Protective coatings
- Cathodic protection

7.1.2 Corrosion Zones

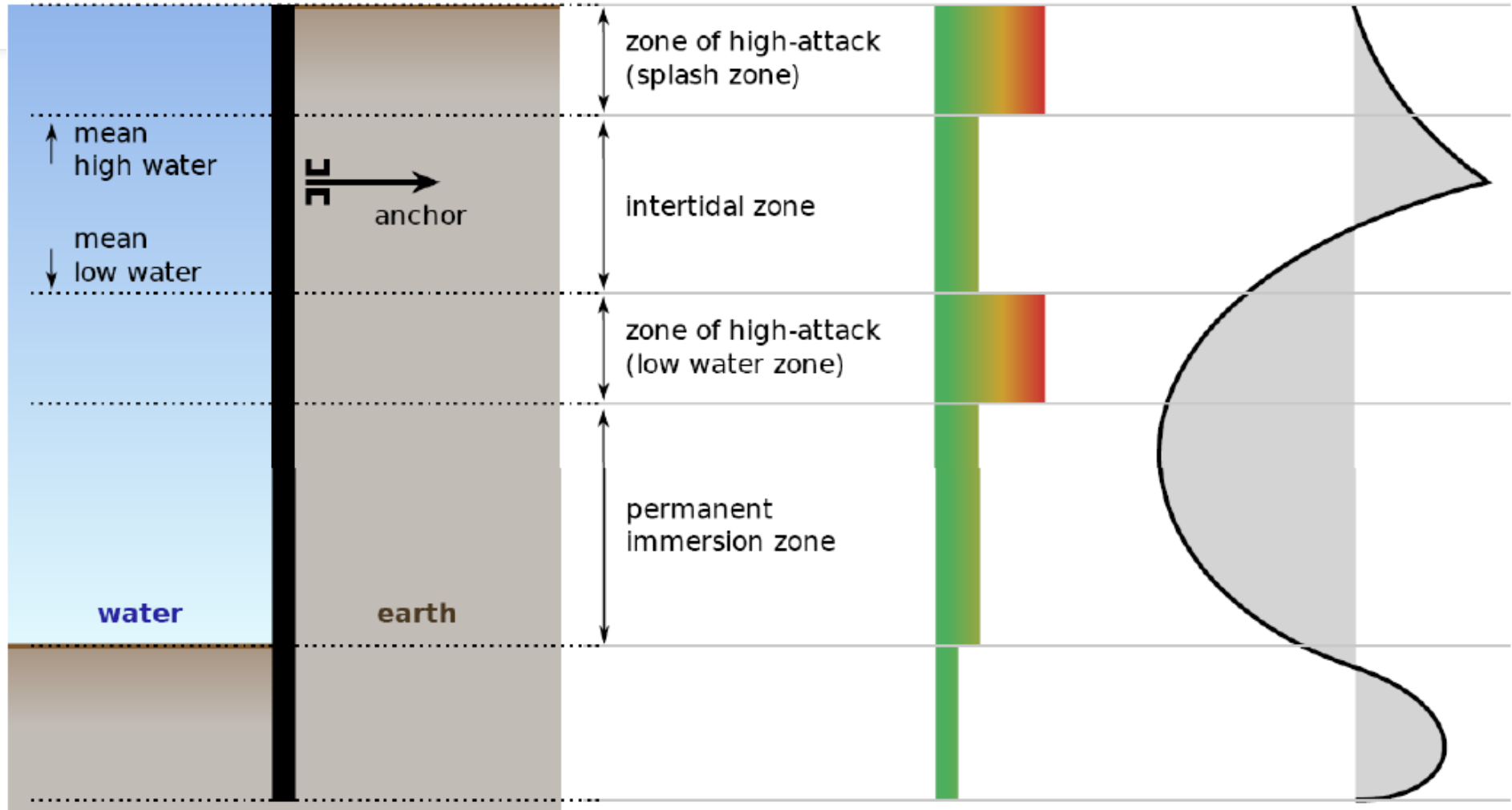

7.1.3 Decision Tree for Corrosion Protection

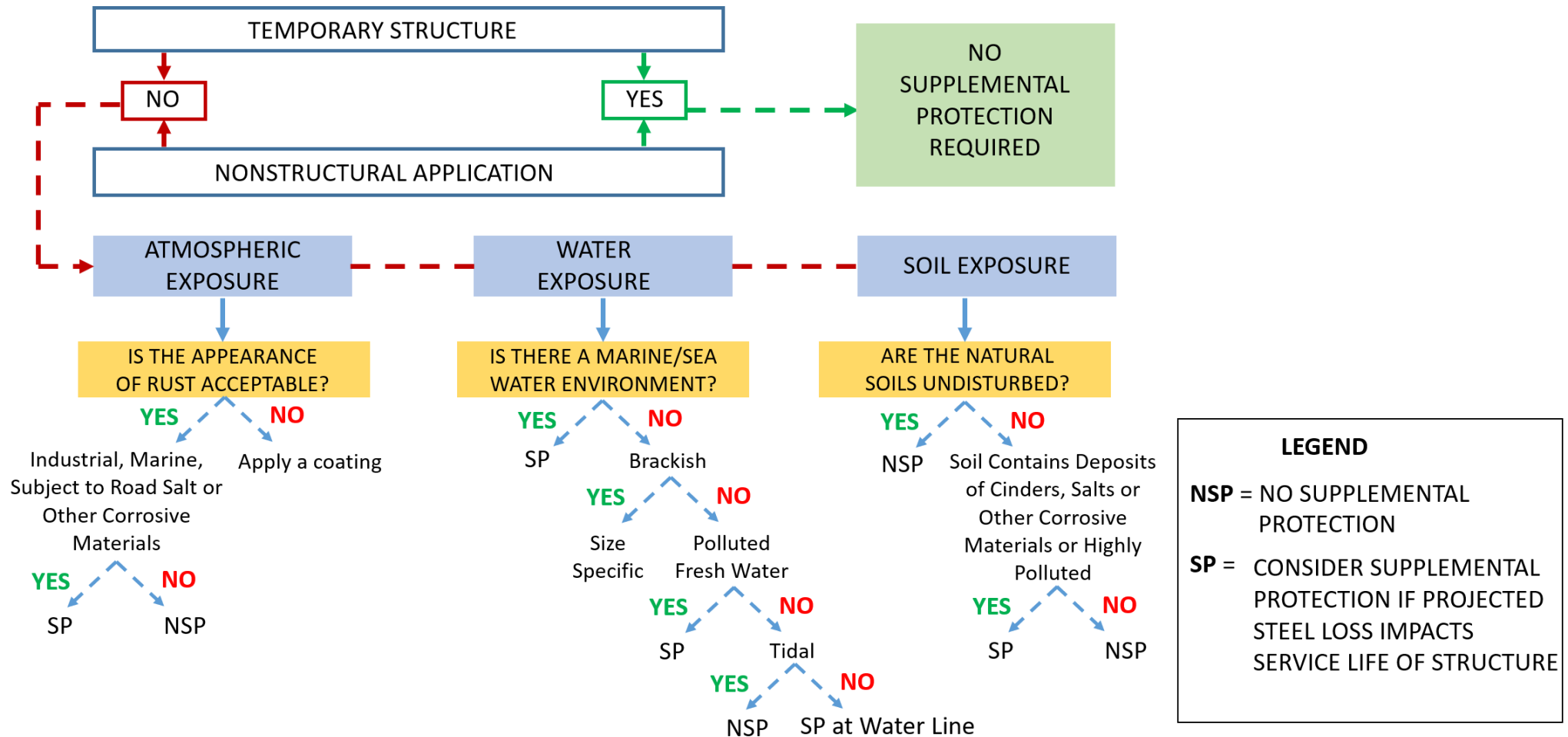

Eurocode 3 Design of Steel Structures

Part 5: Piling (ENV 1993-5)

Loss of thickness (mm)

TABLE 1.

Loss of Thickness Due to Corrosion for Steel Sheet Piling (Ref 4) ^A

Soil, with or without groundwater:	DESIGN LIFE:				
	5 years	25 years	50 years	75 years	100 years
Undisturbed natural soils	0.00 mm	0.30 mm	0.60 mm	0.90 mm	1.20 mm
Polluted natural soils and industrial grounds	0.15 mm	0.75 mm	1.50 mm	2.25 mm	3.00 mm
Aggressive natural soils (swamp, marsh, peat...)	0.20 mm	1.00 mm	1.75 mm	2.50 mm	3.25 mm
Non-compacted and non-aggressive fills ^B (clay, schist, sand, silt...)	0.18 mm	0.70 mm	1.20 mm	1.70 mm	2.20 mm
Non-compacted and aggressive fills ^B (ashes, slag...)	0.50 mm	2.00 mm	3.25 mm	4.50 mm	5.75 mm
Water ^C :					
Common fresh water (river, ship canal,...) in the zone of high attack (water line)	0.15 mm	0.55 mm	0.90 mm	1.15 mm	1.40 mm
Very polluted fresh water (sewage, industrial effluent,...) in the zone of high attack (water line)	0.30 mm	1.30 mm	2.30 mm	3.30 mm	4.30 mm
Sea water in temperate climate in the zone of high attack (low water and splash zones)	0.55 mm	1.90 mm	3.75 mm	5.60 mm	7.50 mm
Sea water in temperate climate in the submerged zone or tidal zone	0.25 mm	0.90 mm	1.75 mm	2.60 mm	3.50 mm

A. Values are provided for general guidance only. Local knowledge may lead to the use of other values for design. The values given for 5 and 25 years are based on measurements, whereas other values are extrapolated.

B. In compacted fills, these corrosion losses should be divided by two.

C. The highest corrosion rate is usually found at the splash zone of marine environments or at the low water level in tidal waters. However, in most cases, the highest bending stresses occur in the submerged zone.

7.1.4 Section modulus vs. reduction in thickness

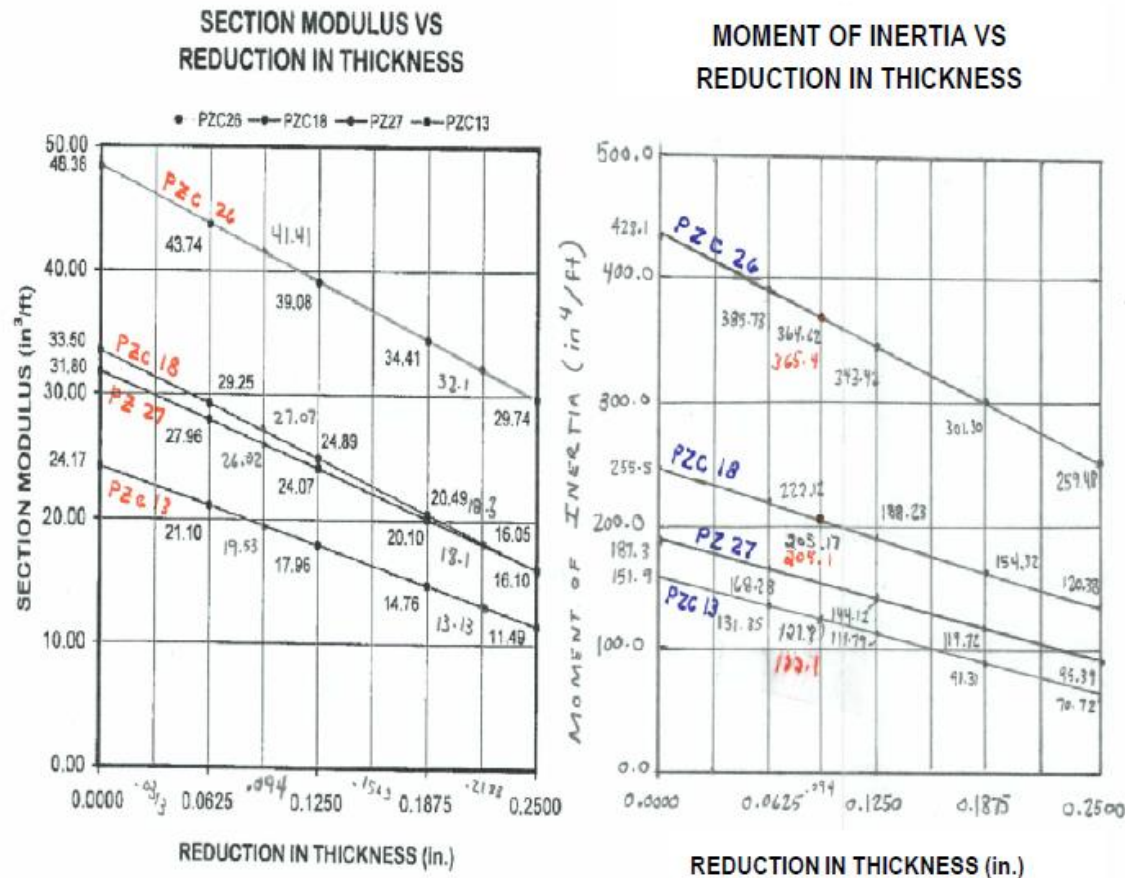

7.1.5. Sheet pile design life

- EC, USACE consider end of design life when any part of the pile reaches a maximum permissible stress through corrosion loss
- Many state DOT's (Florida, etc), require design life at 85% of full section values (note that could be area or section modulus)
- Latest USACE (2008) piling sections thinner than 0.250 inches restricted to uses with low bending, low corrosion, and low interlocked joint strength in tension.

7.1.6 Mariner Grade Steel ASTM A690

- ASTM A 690/A 690M - 07

1.2 The atmospheric corrosion resistance of this steel is substantially better than that of ordinary carbon steels with or without copper addition (see Note 1). The steel has also shown to have substantially greater resistance to seawater “Splash Zone” corrosion than ordinary carbon steel (Specifications A 36/A 36M and A 328/A 328M) where exposed to the washing action of rain and the drying action of the wind or sun, or both. Where the steel is not boldly exposed, the usual provisions for the protection of ordinary carbon steel should be considered.

- ASTM stated, A690 exhibited 2 to 3 times more resistance in the splash zone...

7.1.7 Galvanized Steel

- Based on AGA (American Galvanizers Association) Tropical Marine exposure, a galvanized system will have a projected life (to 5% of surface rust) in excess of 75 years.
- Galvanized coating life determined by thickness and severity of exposure conditions.
- Typical protection 3 to 7 mils.
- Expected service life defined when 5% rusting of the steel substrate occurs. At 5% surface rust, no steel integrity lost; time to consider applying new corrosion protection.

7.1.8 Hot-dip galvanized steel service-life chart

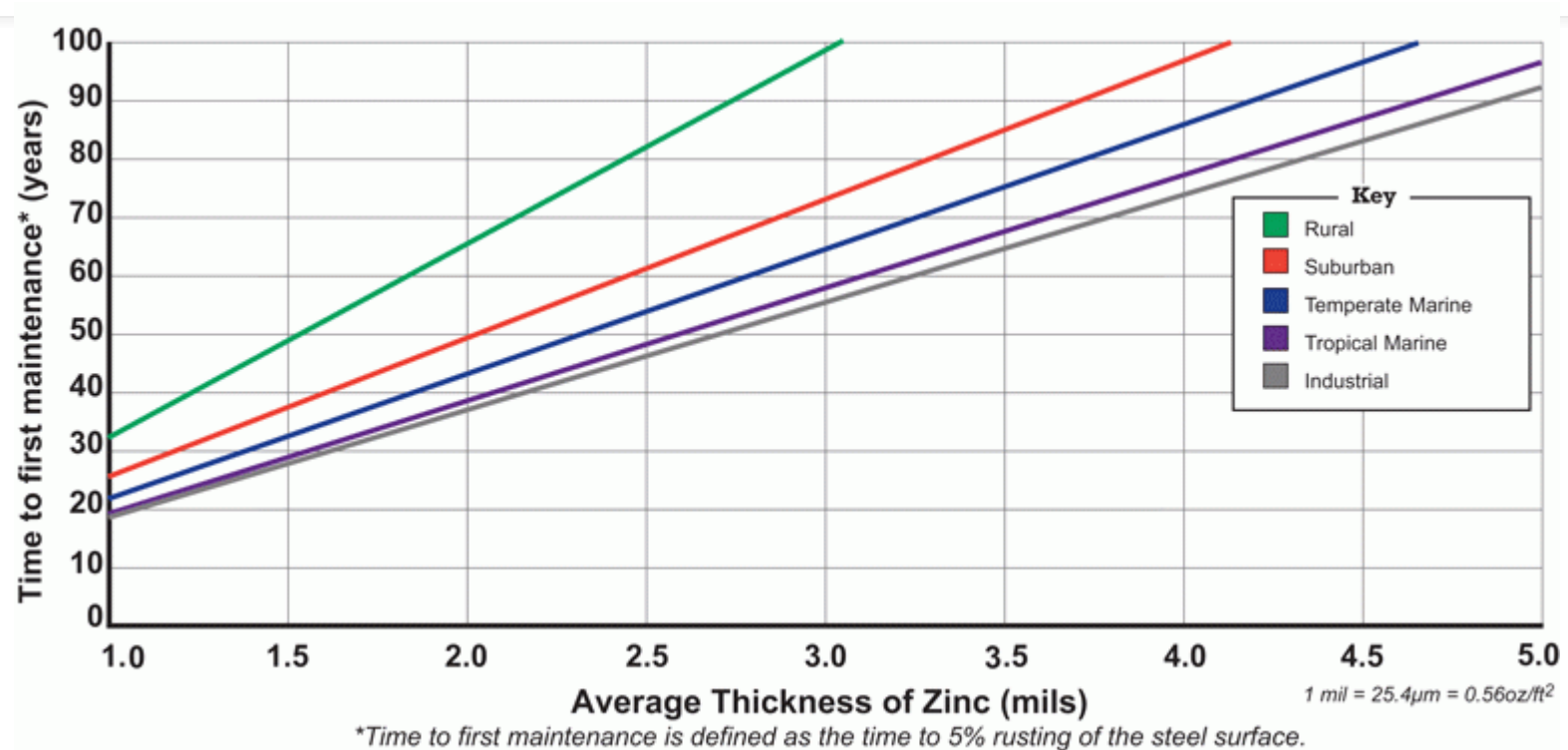

7.2 Cathodic protection

- Required if design life cannot be achieved by other methods
- If used with a coating system, Cathodic protection becomes effective when the coating life ends.
- Types:
 - Impressed current
 - Sacrificial anode
- Continuous as long as system is maintained – 5 year typical system review (base metal anode replacement, electrical continuity upgrade at 20 years)

7.3 Indicative design life cost comparison

Option	Describe	AZ13	Life	AZ18	life
1	Base section	\$8.0/ft ²	32 years	\$9.0/ft ²	41 years
2	Marine grade A690	+\$0.75/ft ²	+32 years	+\$0.85/ft ²	+41 years
3	Higher grade steel	+\$0.22/ft ²	+6 years	+\$0.24/ft ²	+ 8 years
4	Coatings (both sides)	+\$2.60/ft ²	+15 years	+\$2.85/ft ²	+15 years
5	Cathodic protection	+\$6.25/ft ²	+20 years	+\$6.25/ft ²	+20 years

Adapted from Skyline Steel, LLC example for an 800ft x 40 ft wall without coating

7.4.1 Example

- Wall at El. +8
- Seafloor at El. -10, sloping down 10 deg
- Anchor rod at El. +1.5
- Deadman block at El. +4.5

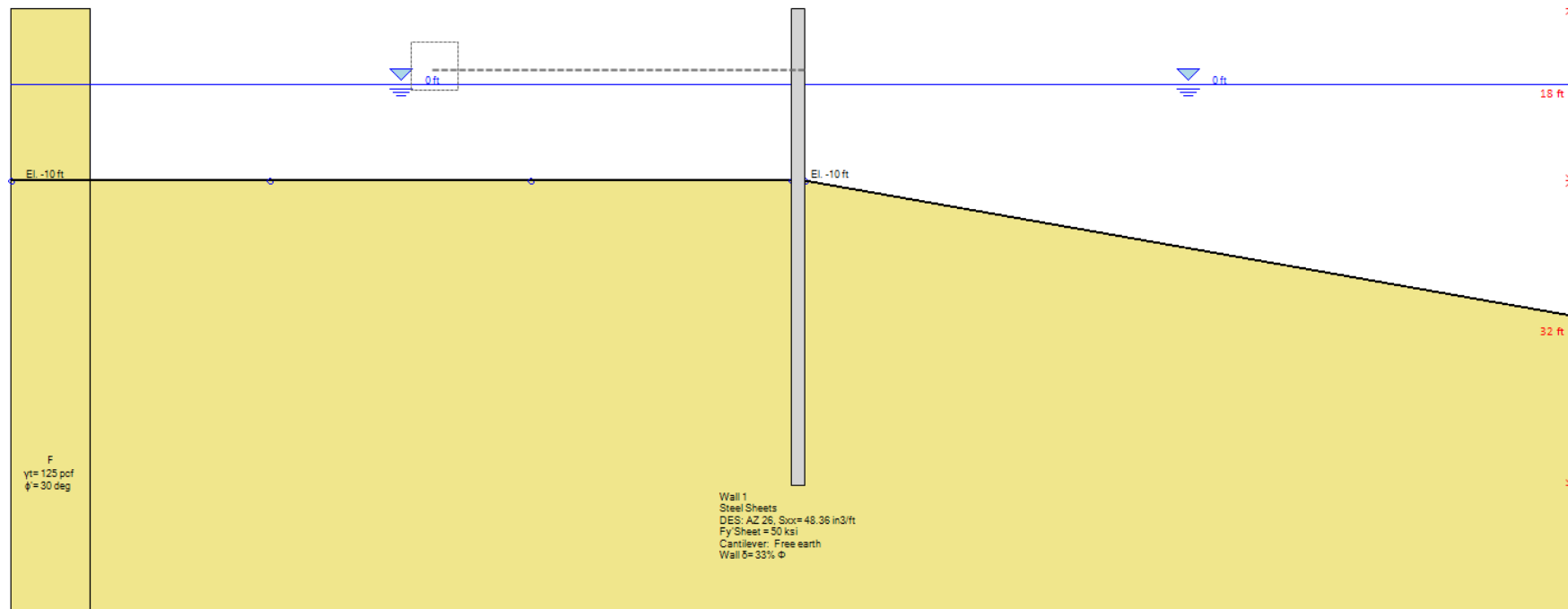

7.4.2 Staging

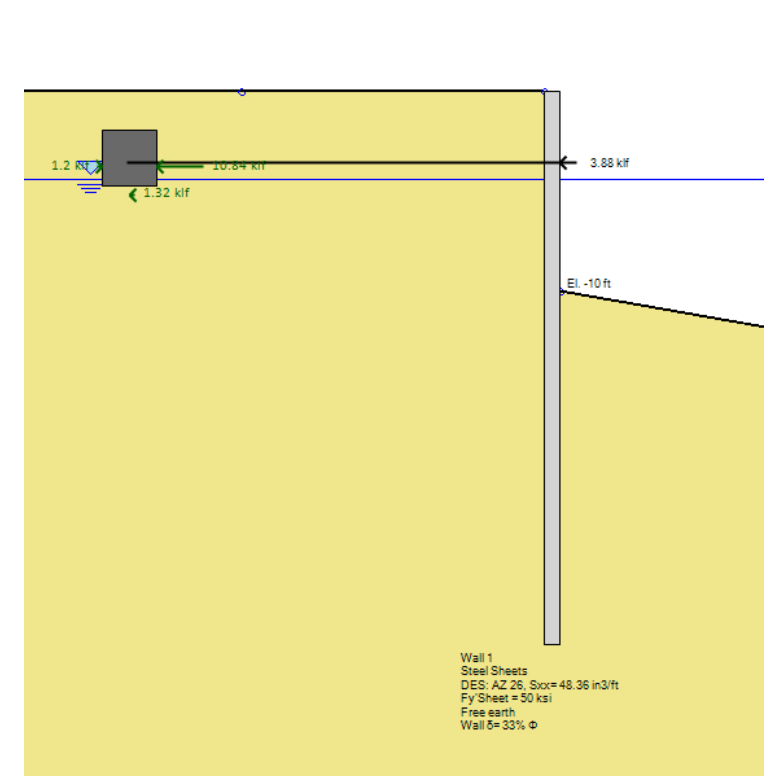
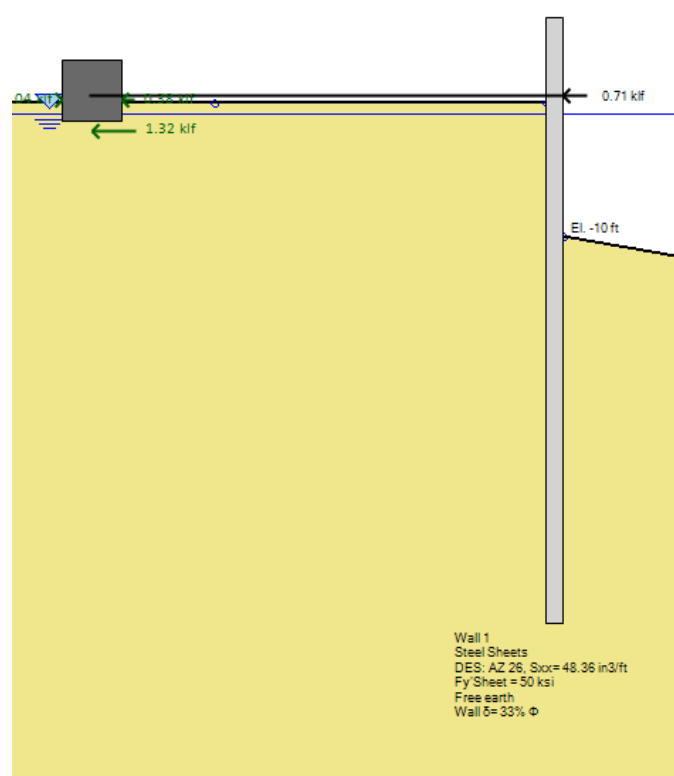
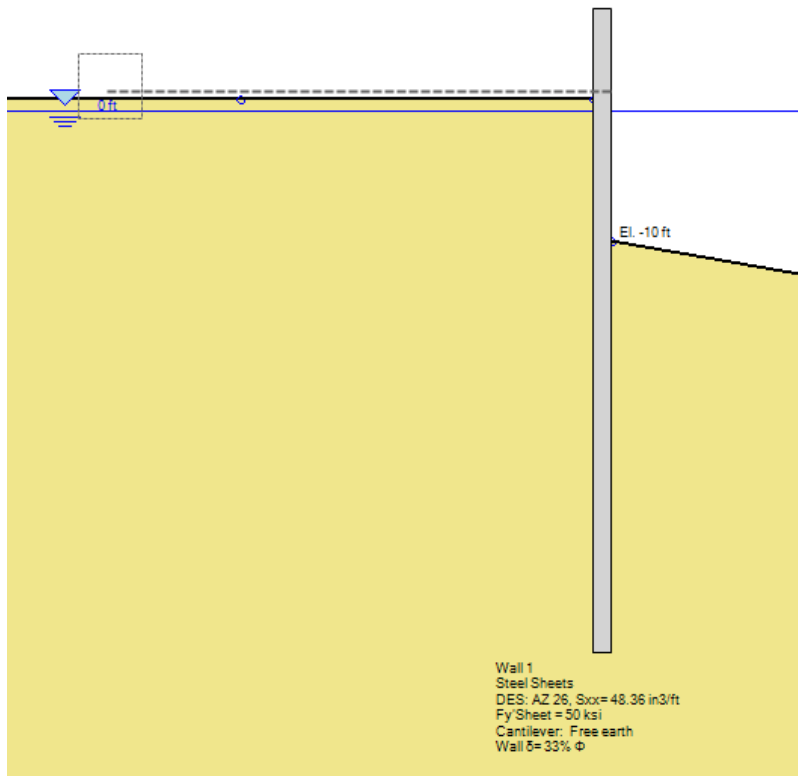

7.4.3 Design Life Settings

Steel Section Corrosion Options

1. Consider Corrosion and Design Life
 Examine design life for all stages (usually selected for last stage only)

2. Design life
Design life in years: 50
Defined corrosion rates: [dropdown]

3.a Corrosion rates
Corrosion rate in splash zone (high attack): 0.0029527 in/year
Corrosion rate in soil: 0.0013779 in/year
Corrosion rate in intertidal zone: 0.0029527 in/year

4. Water elevations (relative or absolute)
 Use absolute water elevations
Mean high water: 1.5 ft
Low water table: -5 ft
Splash depth: + 3 ft
- 3 ft

5. Thickness requirements
Min. recommended thickness: 0.25 in
 Examine minimum section properties percentage (i.e. Florida DOT 85%)
85 %

Apply settings to stages
 Apply to all stages
 Apply to one stage: Stage 4 Corosion
 Apply to stages: From stage: Stage 0 To stage: Stage 4 Corosion

OK Cancel

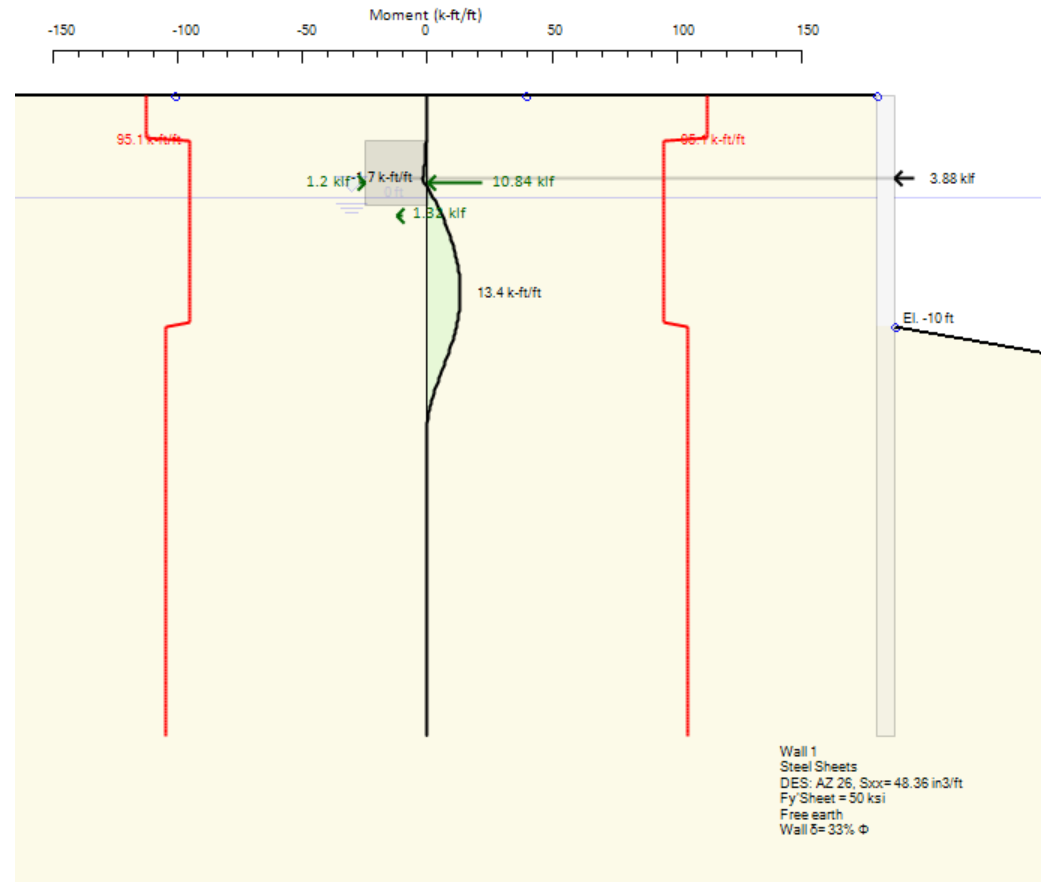

7.4.4 Water Level Difference & Optimization

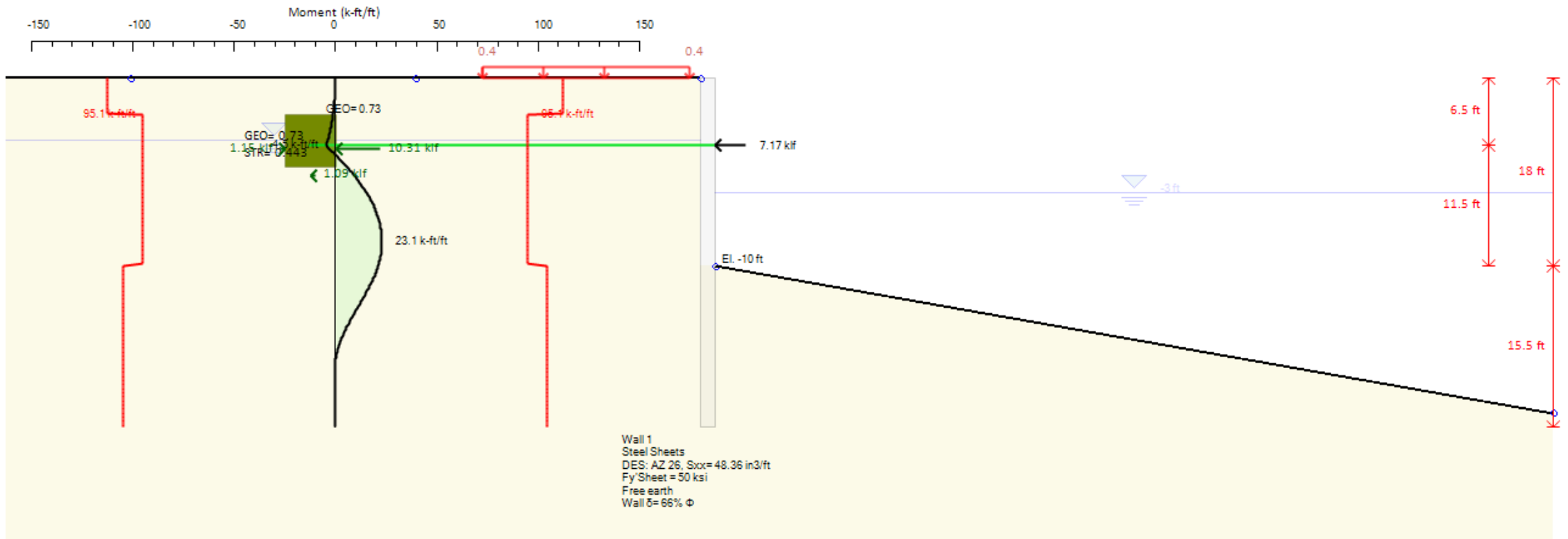

8. Advanced Frame Analysis

- Create typical soil conditions
- Import Buildings from Google Maps
- Draw wall perimeter on map
- Draw cross-sections
- Analyze
- Building damage assesment

8.1.1 Set General Problem

- 10ft fill, 30 deg, 125 pcf
- Clay $S_u = 2000$ psf, 120 pfc
- Water table at -15ft
- Excavation 25ft
- One level of bracing at -8ft
- Secant pile wall W27

DEEP Wizard

1. Welcome 2. Dimensions Soil layers 3. Wall Type 5. Stages 6. Surchar

B. Dimensions

Final Excavation Depth D 25 ft

Wall Height H 55 ft

Excavation Width B 60 ft

Top of Wall Elevation 0 ft

Ground water Elevation -15 ft

Support options

Horizontal Spacing 20 ft

Structural section

Tiebacks and tierods

Struts, rakers, or concrete

Frames, circular shafts, a

Soil Layers

Available Borings

Boring 1

1. General Boring Information - Coordinates

Name Boring 1

Coordinates X -65.617 ft Y 0 ft

The x coordinate controls where the boring is shown in each design section. Each design section uses one boring (soil strata). You can assign multiple borings to a design section.

SPT Data Option (Applies to Design Section)

SPT Record Not assigned

Pass same SPT log to boring (3D visualization)

CPT Record Option (Applies to Design Section)

CPT Record Not assigned

2. Boring Layers - Layer Elevations

	Top Elev.(ft)	Soil Type	OCR
	0	F	1
▶	-10	Clay	1
*			

8.1.2 Setup Secant Wall & Braces

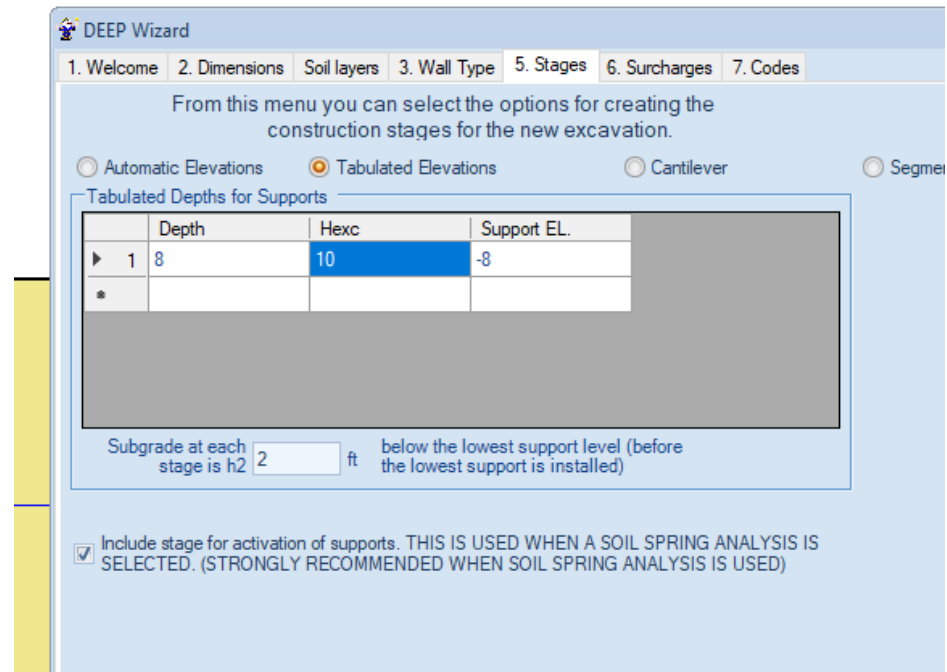
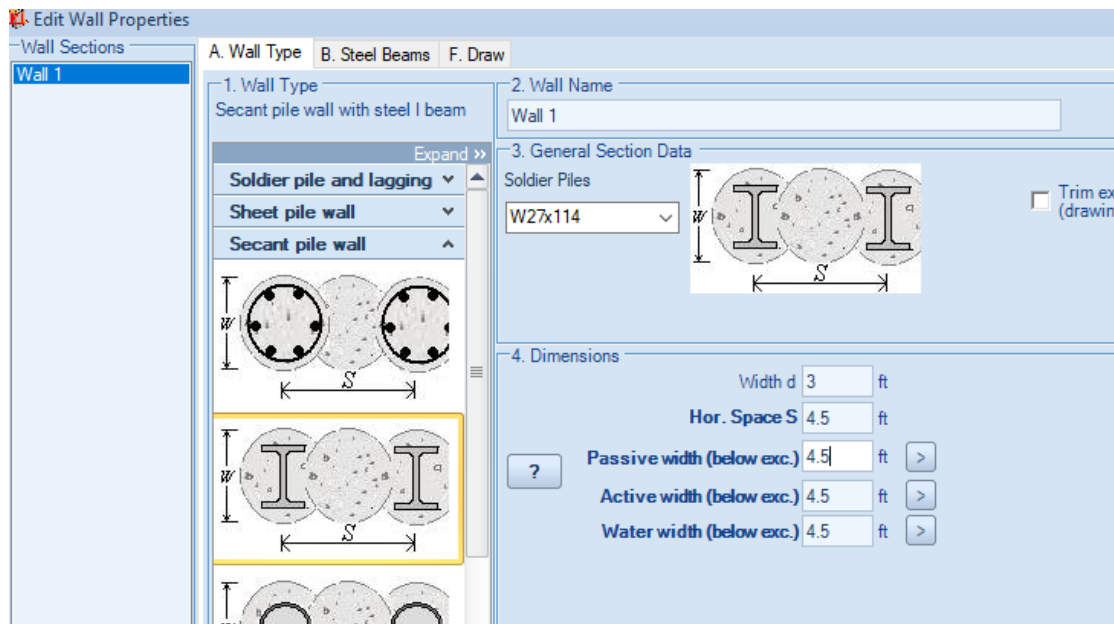

8.1.3 Preliminary Wall Optimization

Wall Toe Safety:	Wall	Wall Toe Safety:	Right wall
Min.FS=	6.582	Min.FS=	6.41
FS Embed=	8.901	FS Embed=	8.901
FS Rot=	6.582	FS Rot=	6.41
Req. toe FS=1:	1.348 ft	Req. toe FS=1:	1.348 ft
Toe El. FS=1:	-26.348 ft	Toe El. FS=1:	-26.348 ft
Note:	Toe FS >= 1	Note:	Toe FS >= 1
Basal standard	3.8	Basal standard	3.8
FS HYD=	1.486	FS HYD=	1.486

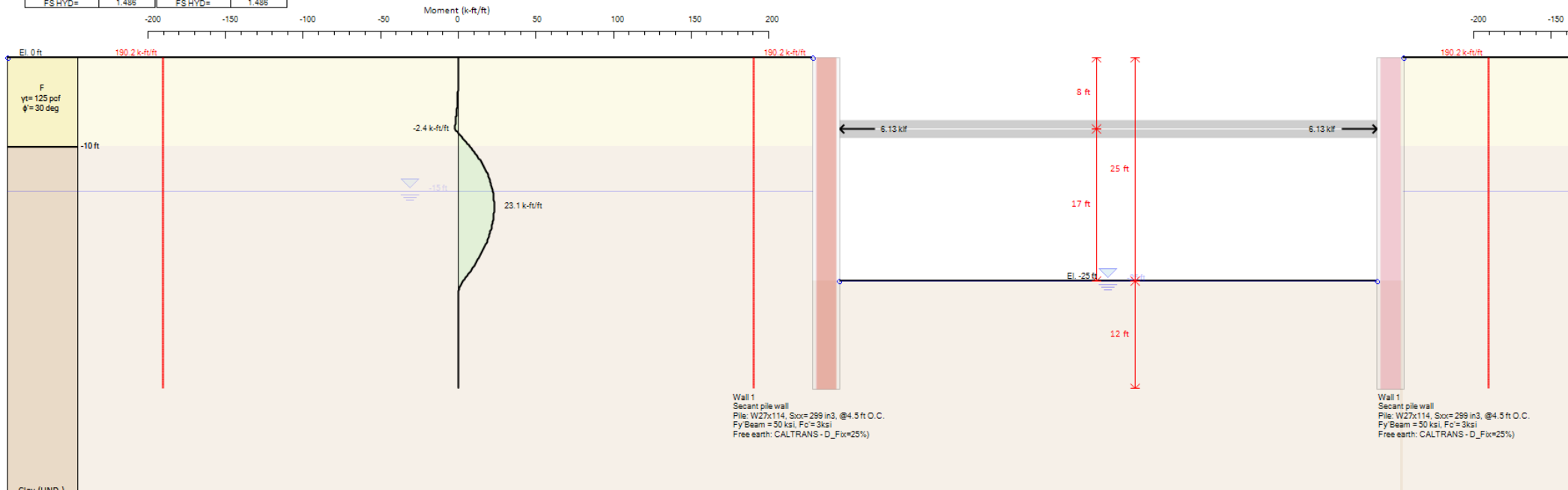

8.1.4 Open Map Function

The screenshot shows a web application interface for an Open Map Function. The interface is divided into a control panel on the left and a main map area on the right.

Control Panel (Left):

- Map information:**
 - Use online map service:
 - Longitude:
 - Latitude:
 - Zoom level:
 - Angle:
- Map type:**
 - roadmap
 - hybrid
 - satellite
 - terrain
- Use paid Google Maps Key
- Image size (pixels):**
 - width:
 - height:
-
-
- Set reference point on screen:**
 -
 - x ref:
 - y ref:
 -
- Scale factor:**
- x Pixel offset:
- y Pixel offset:
-
- Map is visible in map
-

Main Map Area (Right):

The main map area displays a satellite view of a city street intersection. The map shows buildings, roads, and trees. The interface includes a small toolbar at the top of the map area with the following options: Imported Map, Move in free google maps.

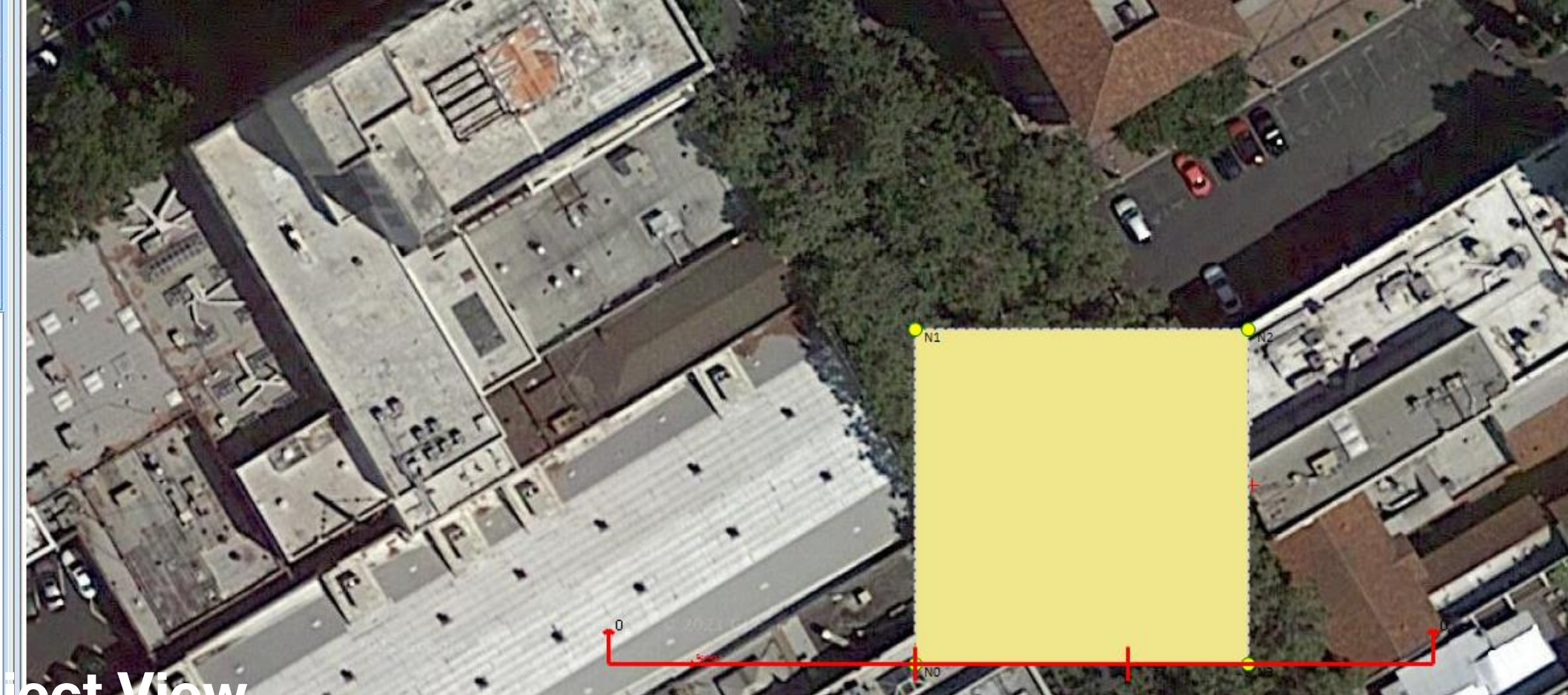
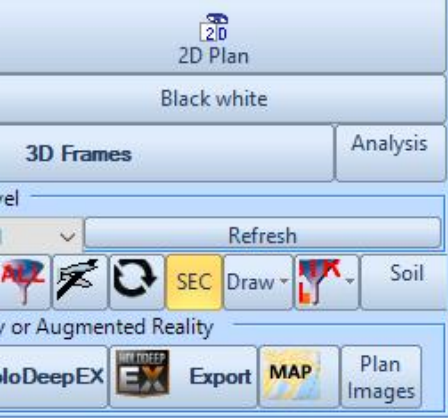

Project View

- Draw project region
- Import buildings from Google Maps



8.1.6 Import Buildings

- Information from Google Earth for terrain
- Cadmapper for Buildings
- Certain buildings might be missing
- Then import in DeepEX

8.1.7 Remove & Move Structures



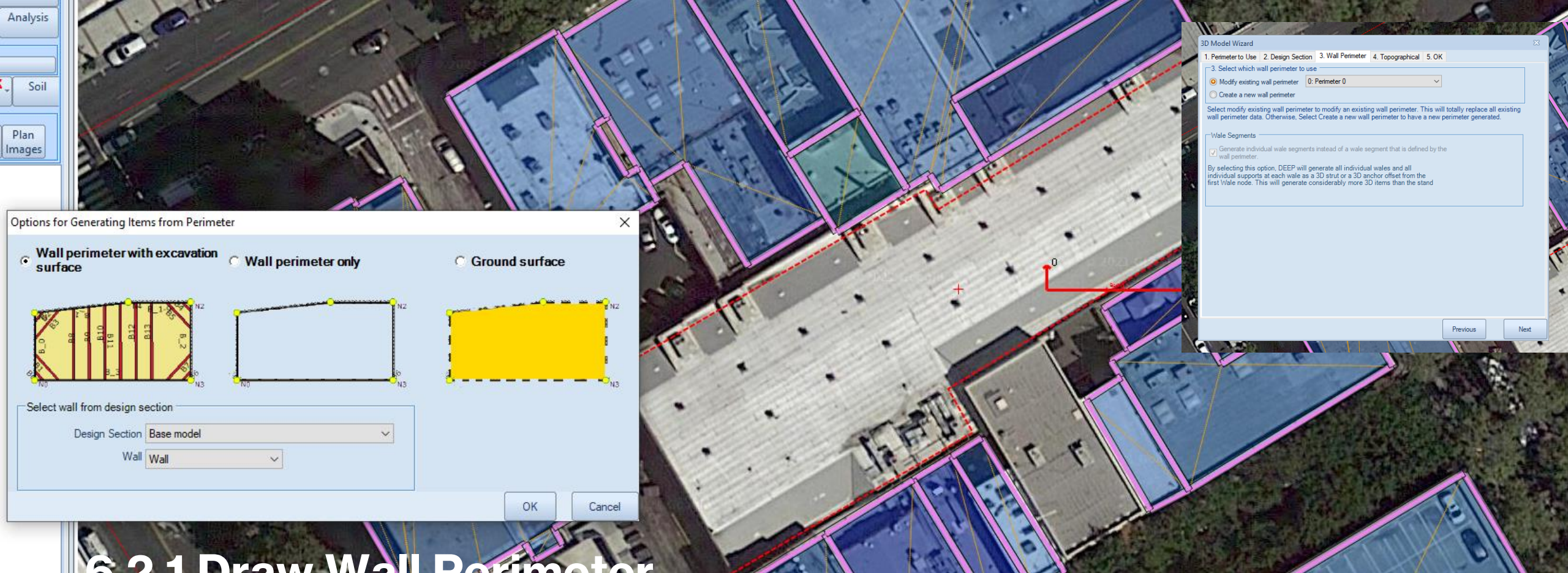

6.2.1 Draw Wall Perimeter

- Draw wall perimeter
- Generate preliminary layout
- Modify existing wall perimeter

7.2.2 Initial and Revised Strut Layout



8.2.3 Re-entrant Corner Walers

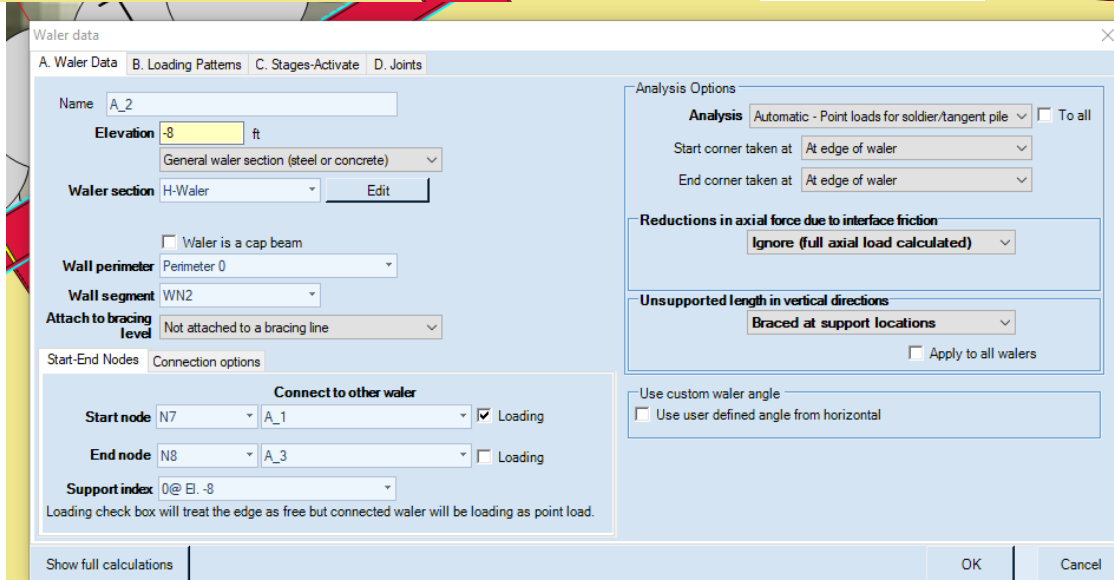
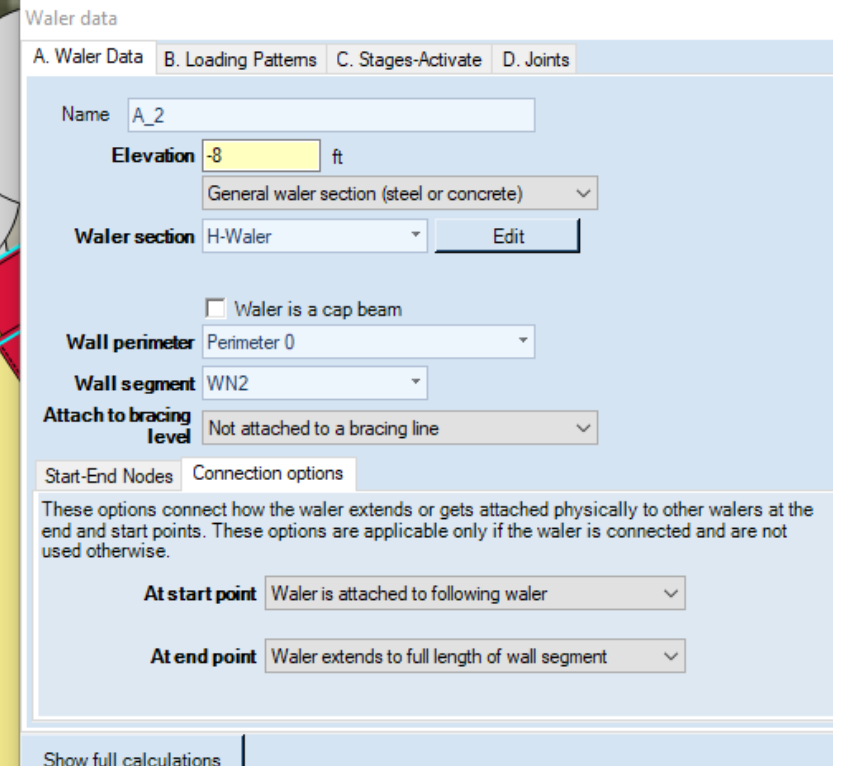
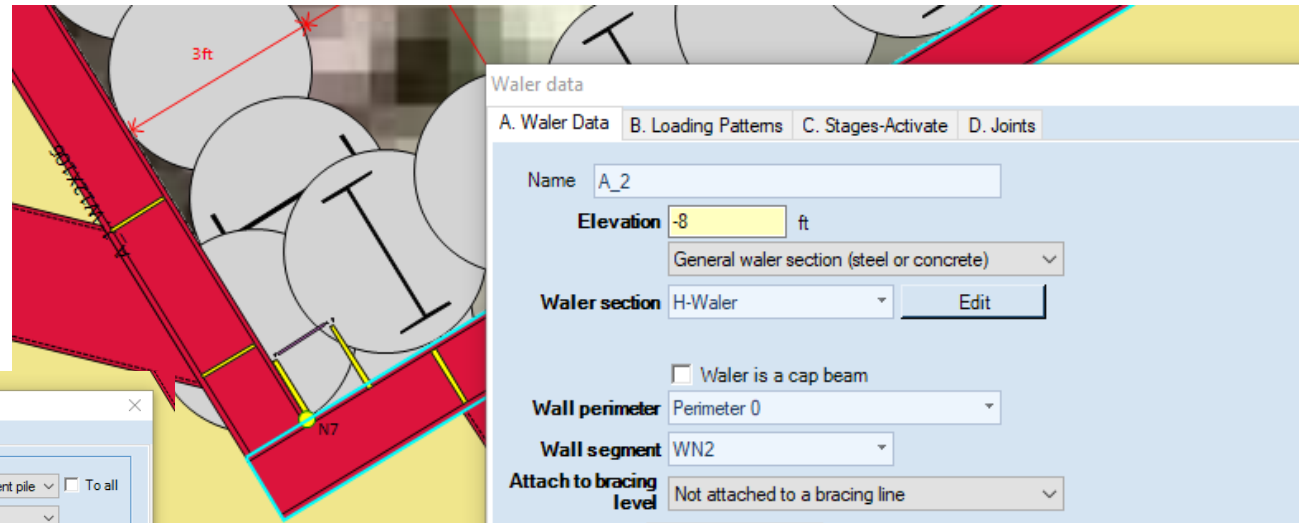
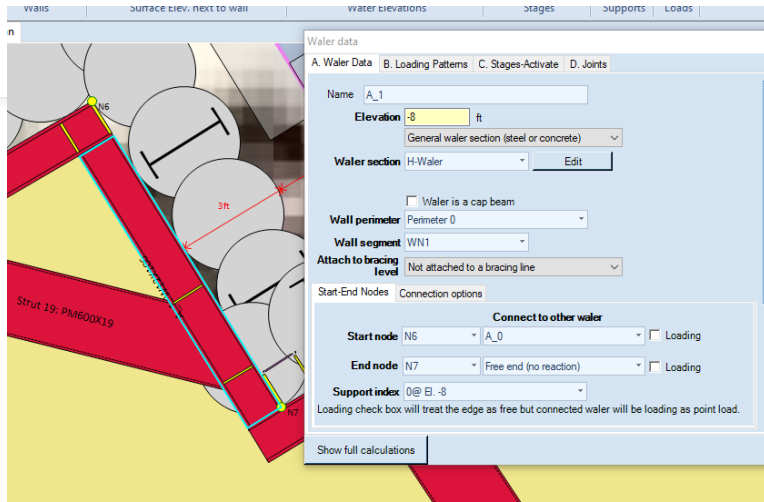

8.3.1 Design Sections

- Reposition 1st design section
- Change project limits

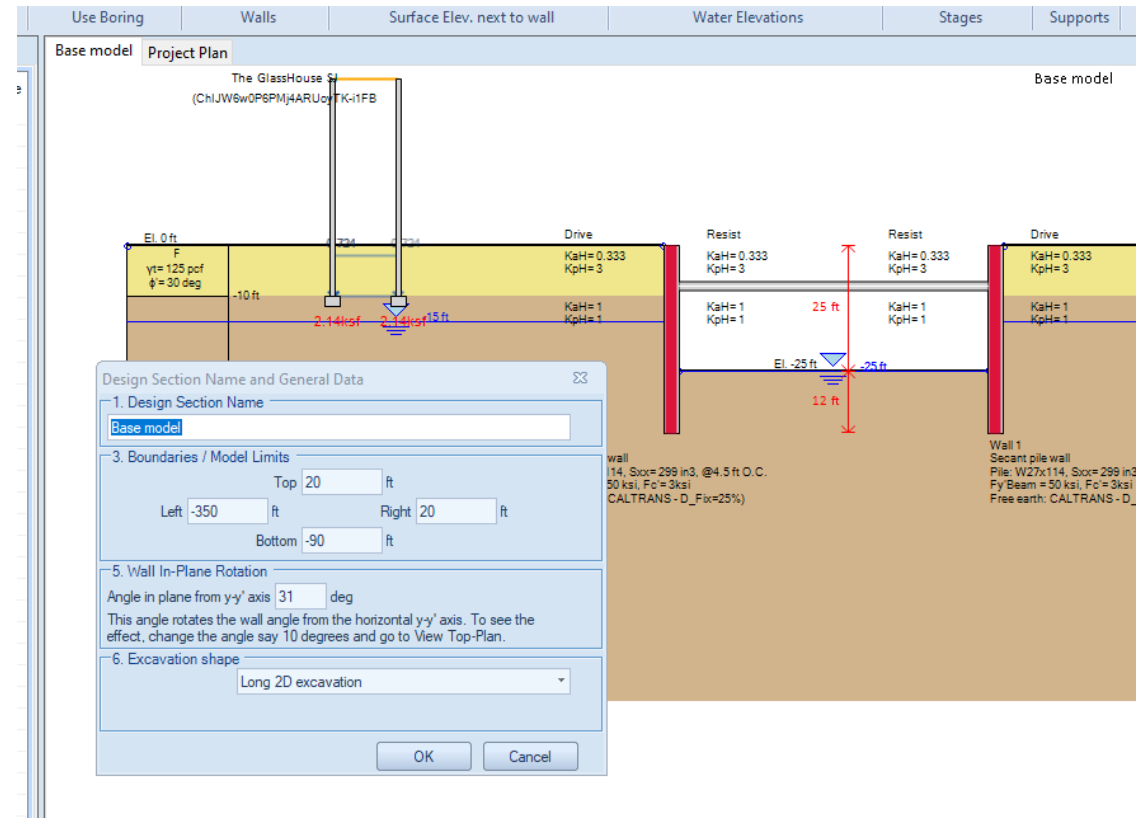

8.3.2 Cut Cross-Sections

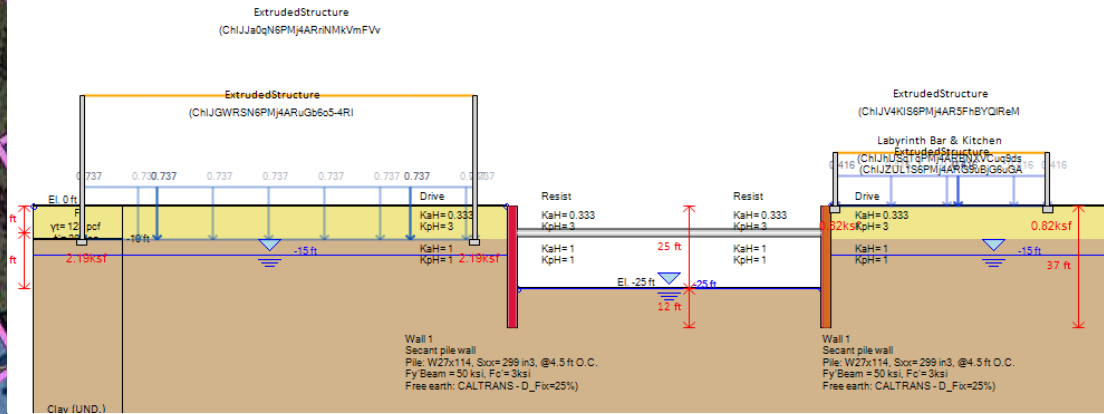

8.3.3 Pass Appropriate Design Sections

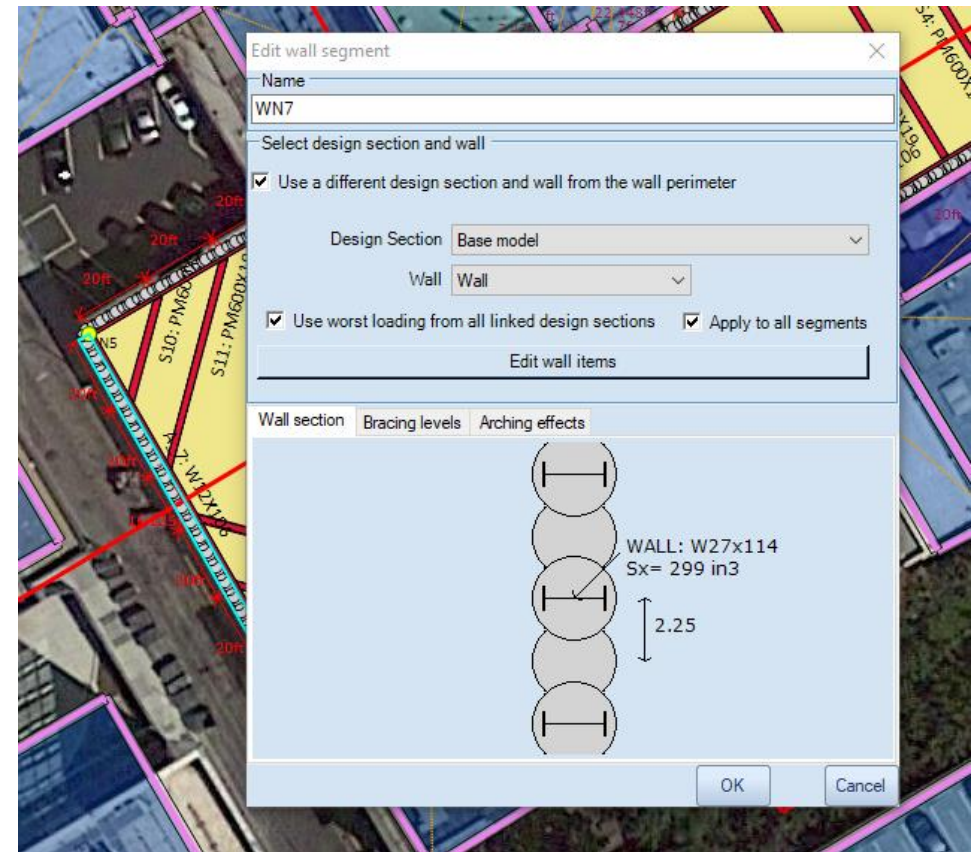
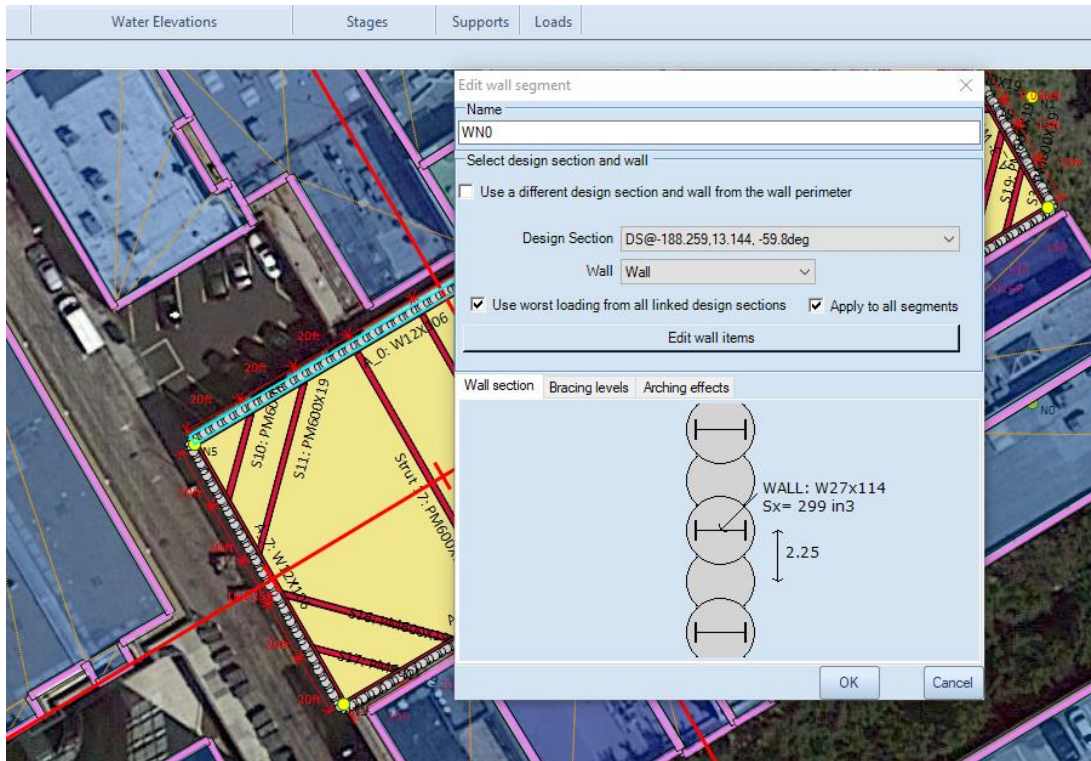

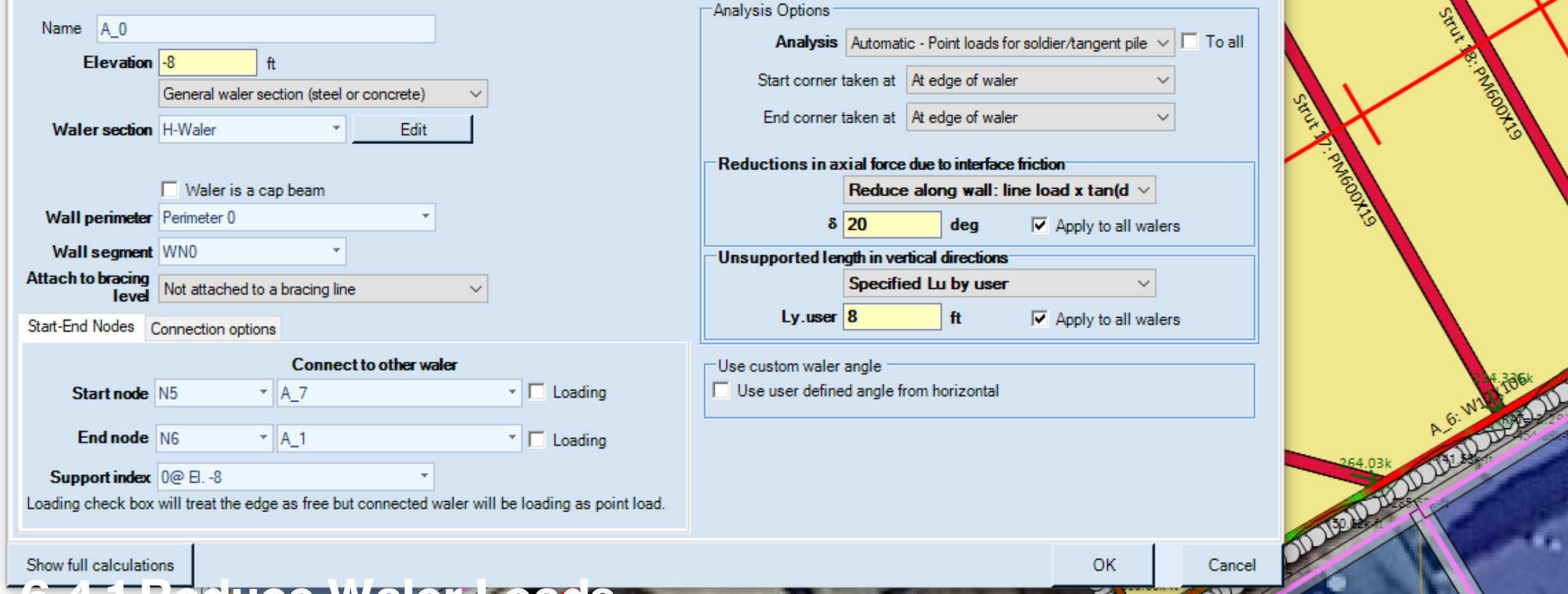

6.4.1 Reduce Waler Loads

- Assume wall friction
- Cut vertical unbraced length

8.4.2 Optimize Waler-Strut Sizes

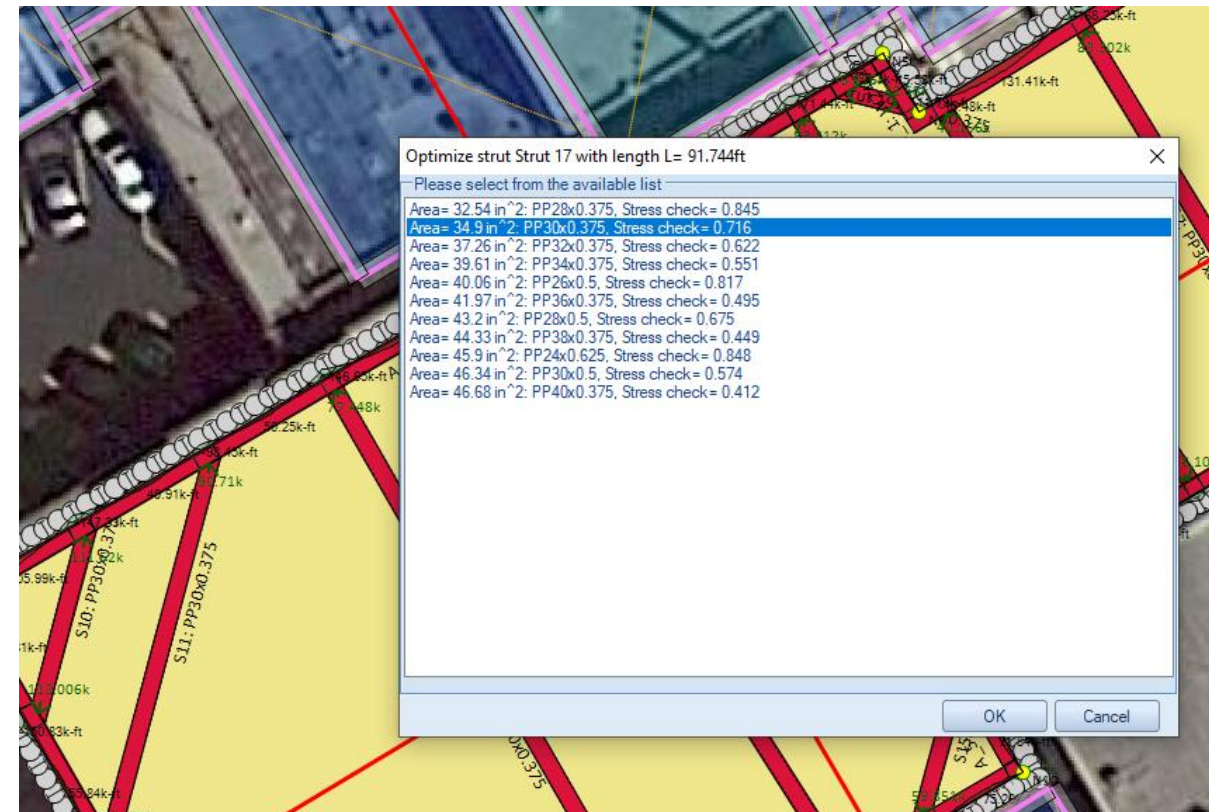
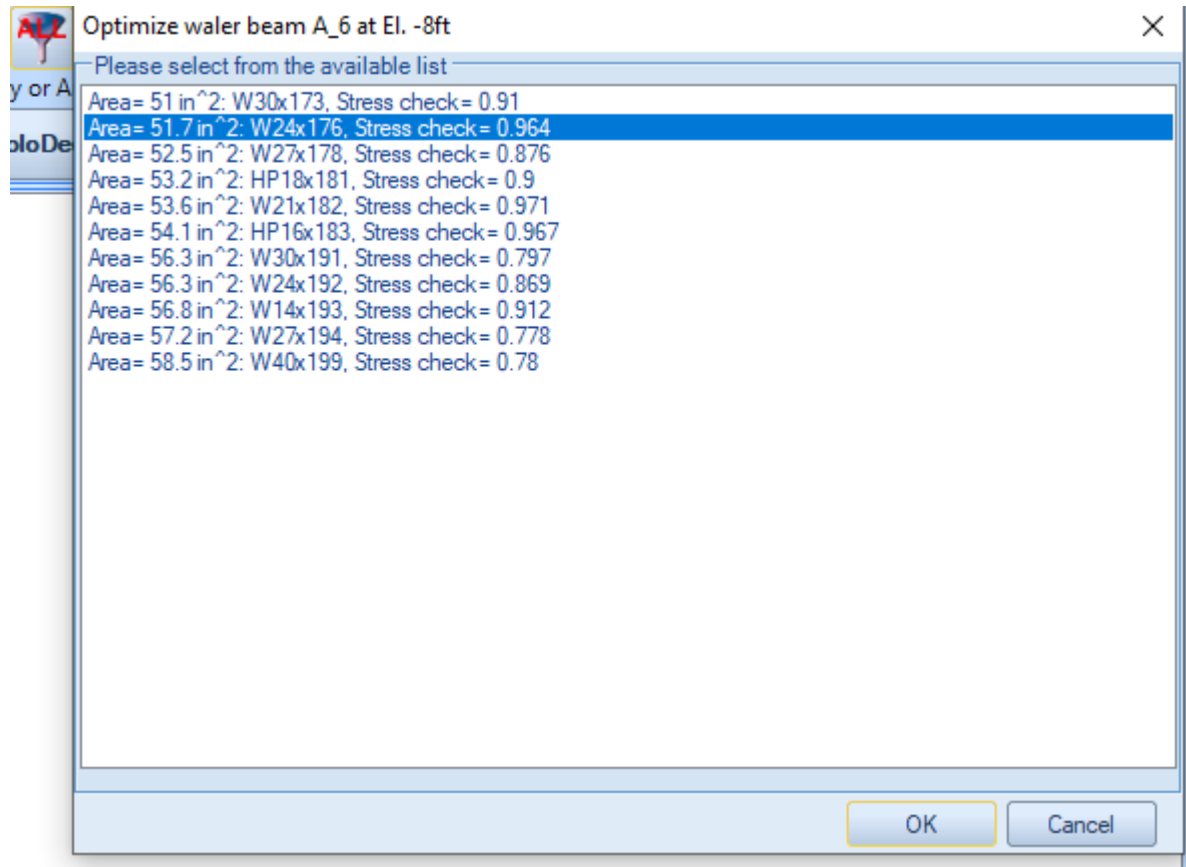

8.5.1 Non-linear analysis & Settlement

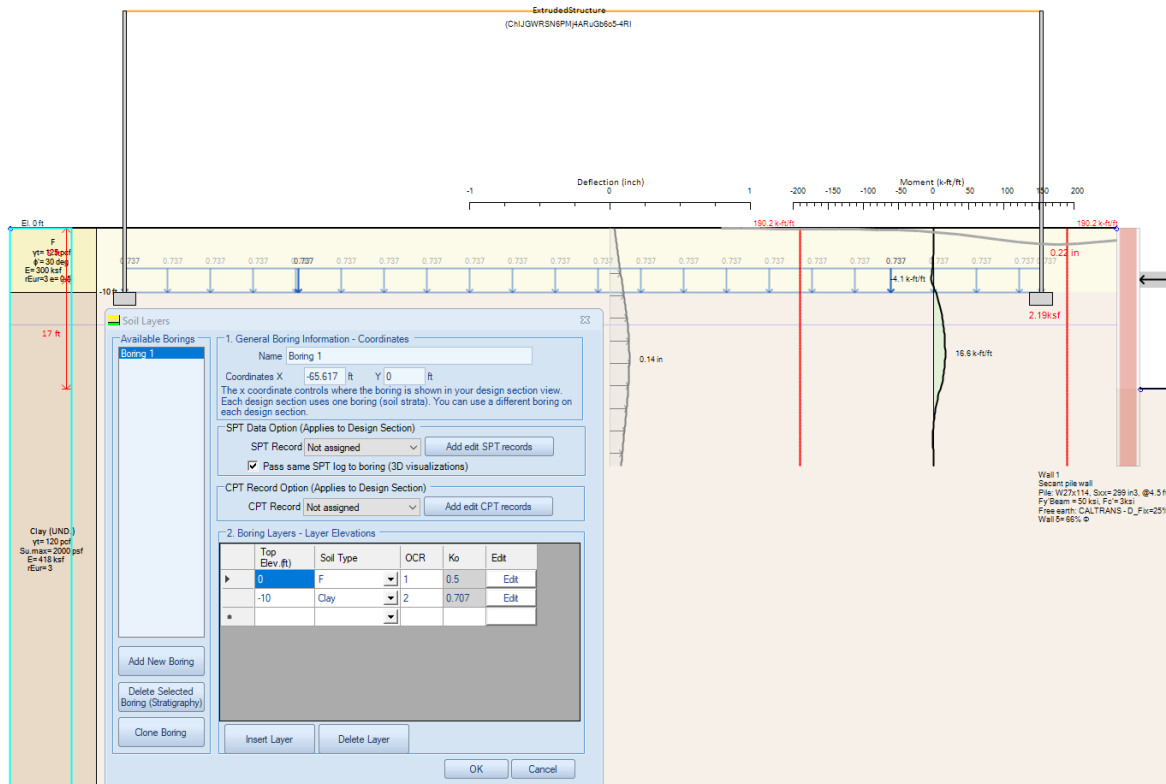

Name: ExtrudedStructure
Source ID (Google etc): (ChIjtc3nM6PMj4ARIE3dWC6La3)

Structural data for load calculations

Dead load on floors qDL: 0.1 ksf
Average floor height H: 12 ft
Average wall density: 0.15 kcf
Base slab thickness Tslab: 1.5 ft

Live load on floors qLL: 0.04 ksf
Average wall thickness Tw: 1 ft

Elevations and options

Top Elevation: 32.8083989501312 ft
Ground Elevation: 0 ft Change Ground Elevation (for building)
Basement height: 10 ft

User specified loading options

Assume user defined pressure for all wall footings
 Assume user defined pressure for all slabs

Damage Assessment Options

Building type: Concrete frame building
Damage Assessment: Based on 3D model (plan view)

Critical strains and type for walls

eCrit: 0.003
 Perform damage assesment when form closes

Critical Wall Crack Strain Profiles

1. Select building/construction type from following list

Full brick walls with supporting concrete beams 1.2 <L/H<3
Full brick walls with supporting concrete beams 1.2 <L/H<3

2. The following table presents critical response modes for various construction methods. A wide range of values is possible. You can select based on the provided range or enter your own critical strain value.

Mode	Min value	Max. value	Used value
Tensile from flexure	0.00038	0.0006	0.00049

19. J. BURHOUSE: Composite action between brick panel walls amd their supporting beams, Proc., Inst. of Civ. Engrs, 1969, Part. III, 5, 782-783

6.5.2 Building Damage Assessment

- Click on a building
- Define critical strains
- 2D-3D assessment

8.5.3 Building Damage Assessment

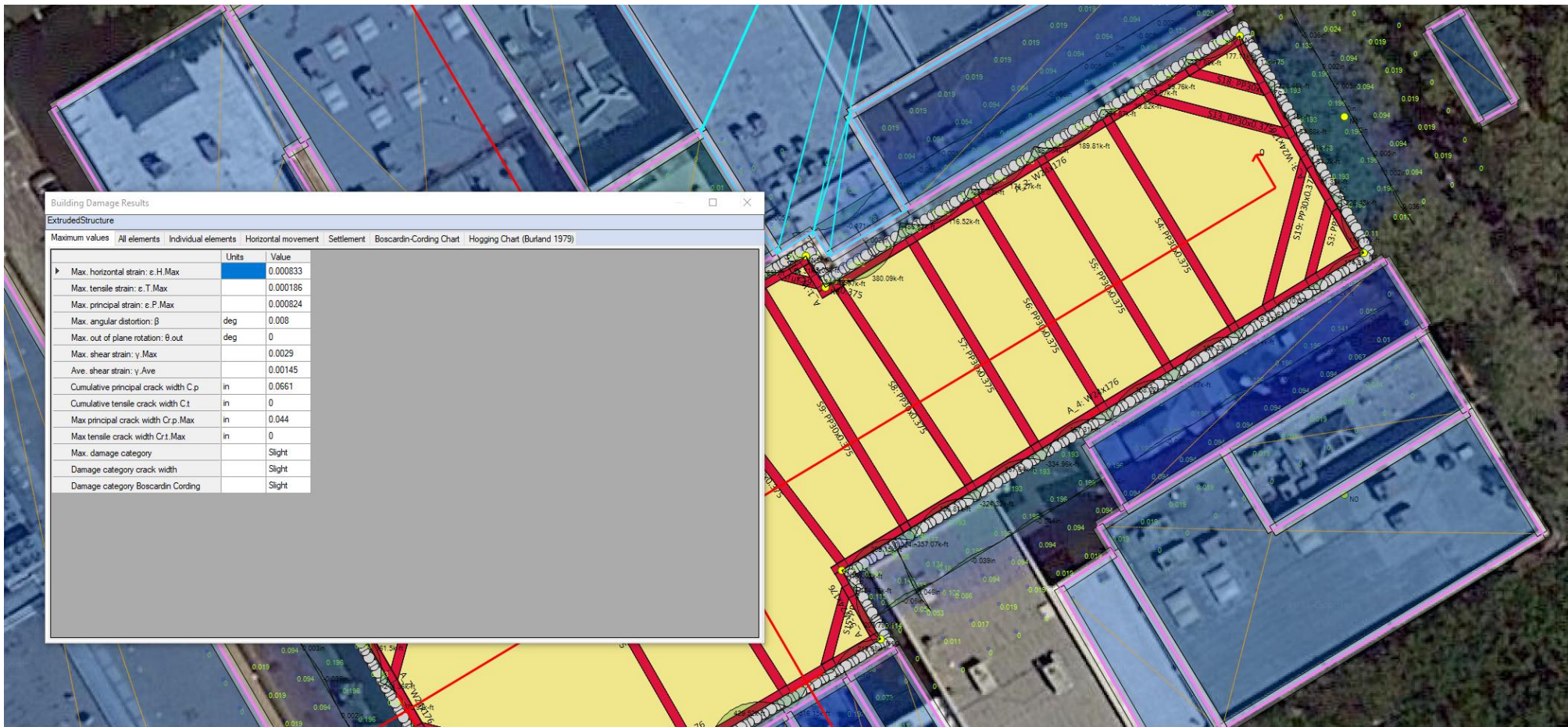

8.6.0 Special 3D Wizard Applications

- Caterpillar excavations
- Arbitrary excavation

8.6.1 Caterpillar SOE

The screenshot displays the 'Caterpillar SOE Wizard' dialog box with the following settings:

- 1. General**
 - Number of openings: 4
 - Reference Point: X 0, Y 0
 - EL: 0, Rotation: 0 deg
 - Hexc: 80, Hwall: 120
 - Equally adjust panel lengths:
 - Intermediate king panel dimensions:
 - Panel face width wK: 8 ft
 - Overall section depth dK: 16 ft
 - Face thickness tK: 5 ft
 - Bracing at king panels: Concrete strut
 - Concrete Section: Conc strut 2
- 2. Left Opening**
 - Shape: Circular without any cuts
- 3. Right Opening**
 - Shape: Circular without any cuts
- Additional Bracing Levels**

	Depth	Hexc	Support EL.
1	8	14	-8
▶ 2	35	41	-35
*			

Subgrade at each stage is h2: 6 ft below the lowest support level (before the lowest support is installed)
- Water**
 - Use design section
 - i: Base model

8.6.2 Caterpillar SOE

- 3D FEM only

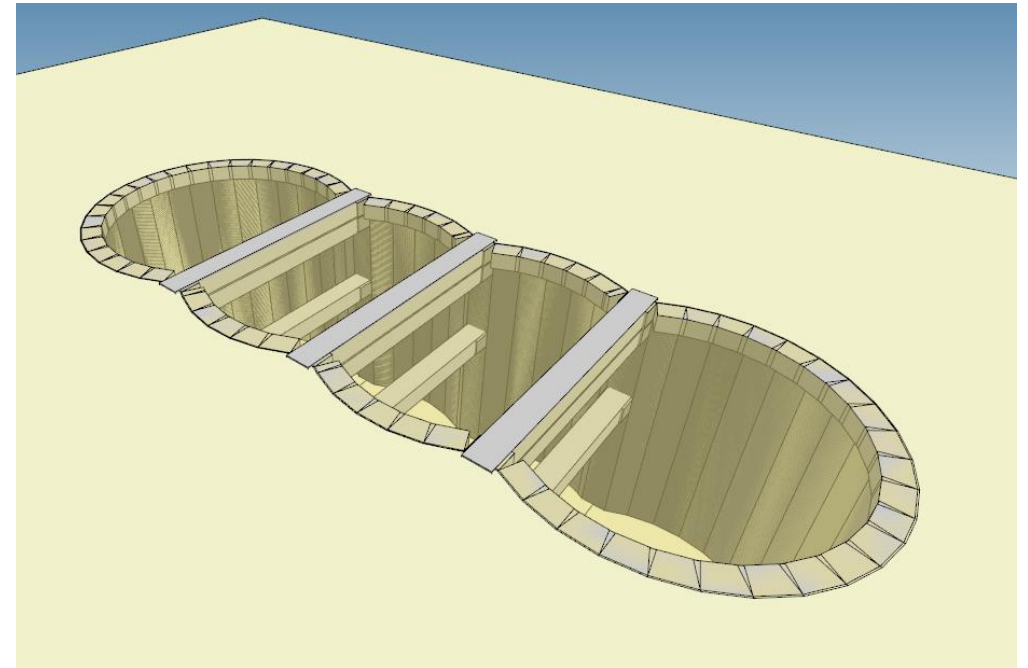
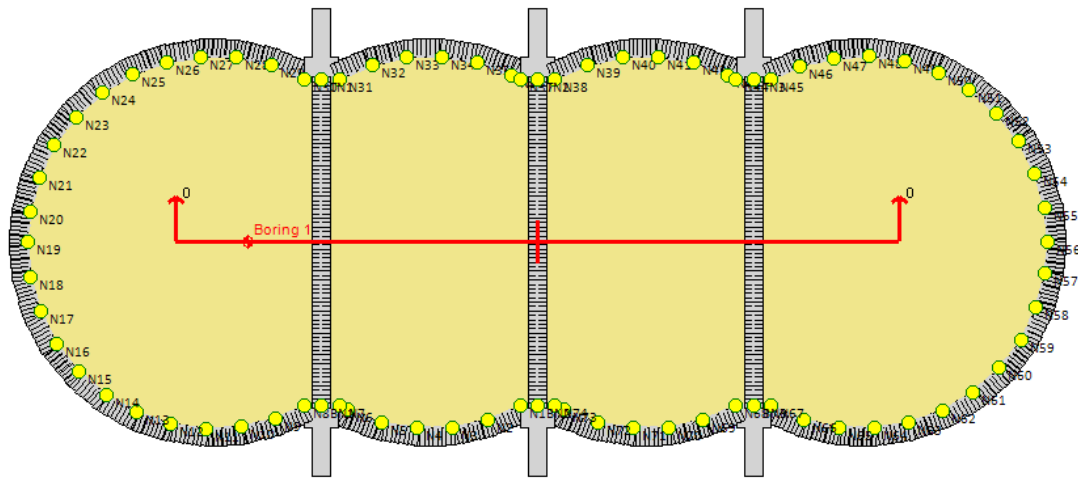

8.6.3 Arbitrary Excavation Shape

DEEP Wizard

1. Welcome 2. Dimensions Soil layers 3. Wall Type 5. Stages 6. Surcharges 7. Codes

B. Dimensions Expand >>

Final Excavation Depth D 45 ft
Wall Height H 50 ft
Excavation Width B 100 ft
Top of Wall Elevation 0 ft

Ground water Elevation -16.404 ft

Edit wall perimeter points

3D Nodes

Name	X	Y	Z	Is Surface
▶*				<input type="checkbox"/>

0 Move X
0 Move Y
0 Move z (elev)

OK Cancel

Tiebacks and tierods

Struts, rakers, or concrete slabs

cantilever excavations

MSE

9. Steel connections



9.0.1 Waler connected to diaphragm wall

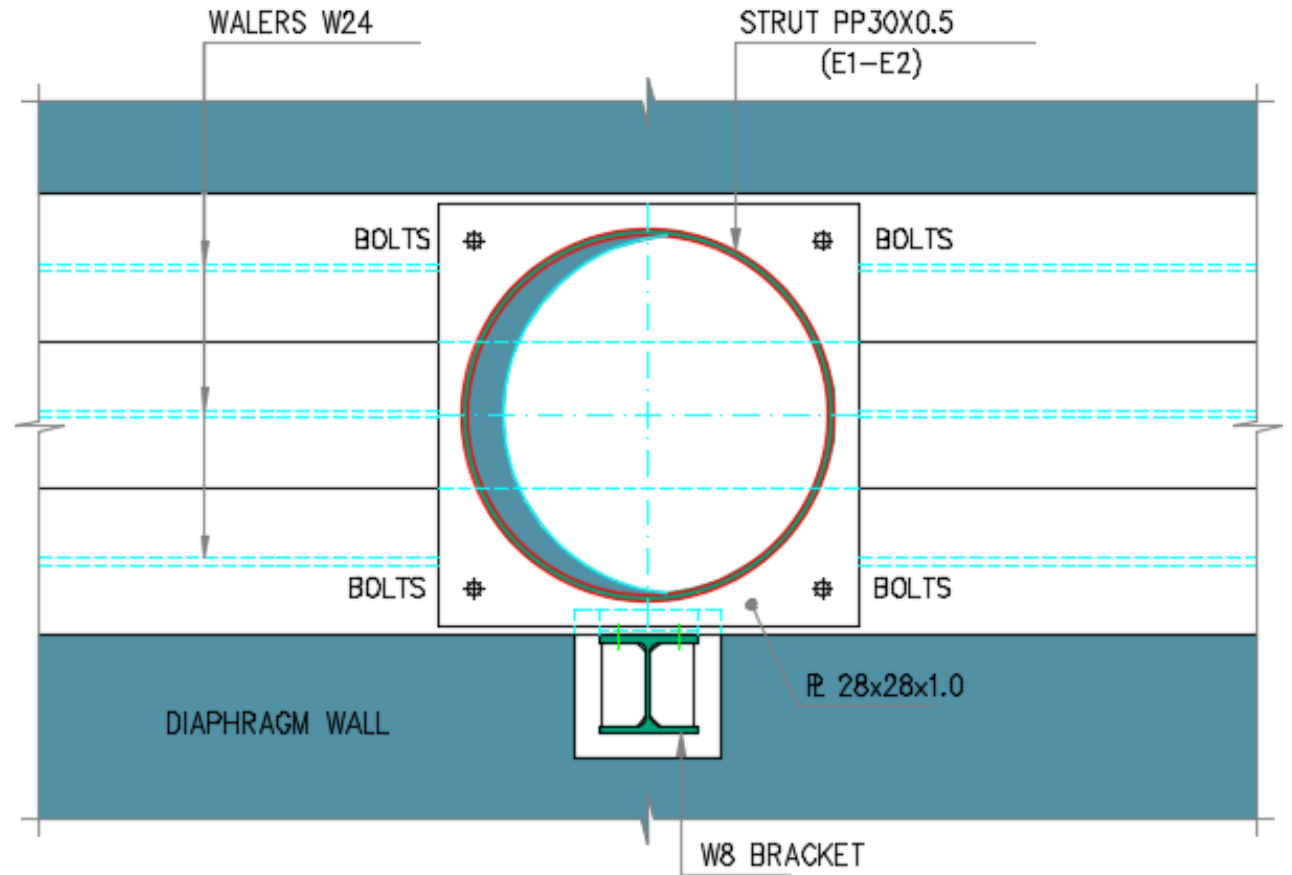
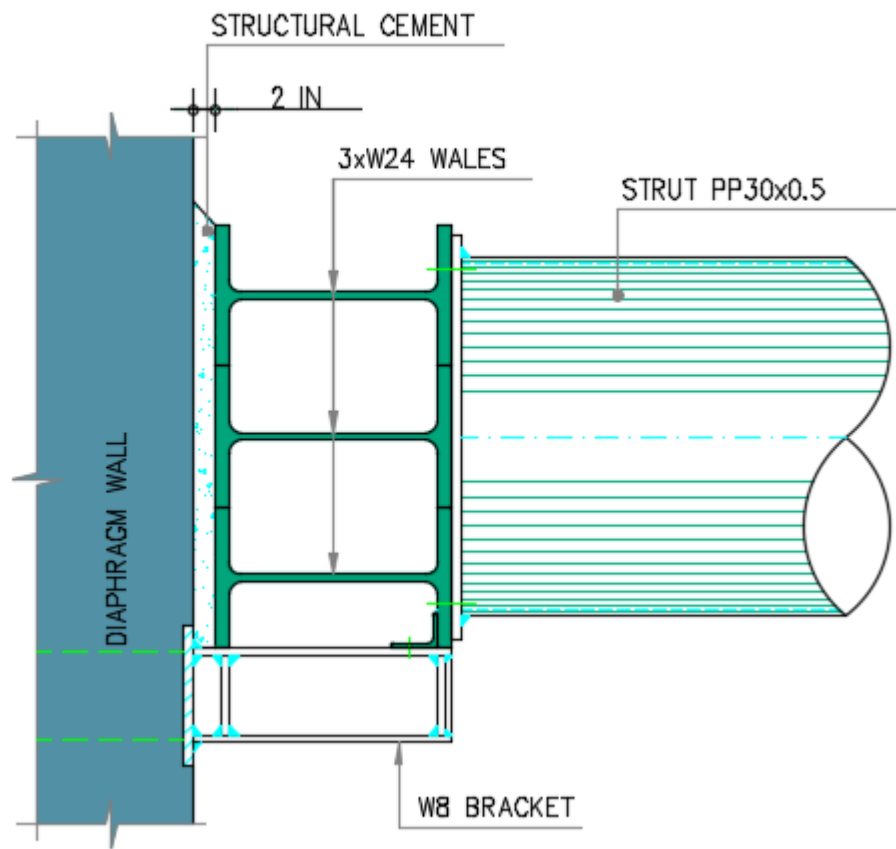

9.0.2 Double channel waler

- On soldier pile walls
- Typical to use one channel with one tieback per two piles
- Channels designed for moment

$M = PL/4$ for both channels

$$M_{DES} = \frac{\frac{PL}{4}}{2 \text{ Channels}}$$

8.0.3 Double channel walers

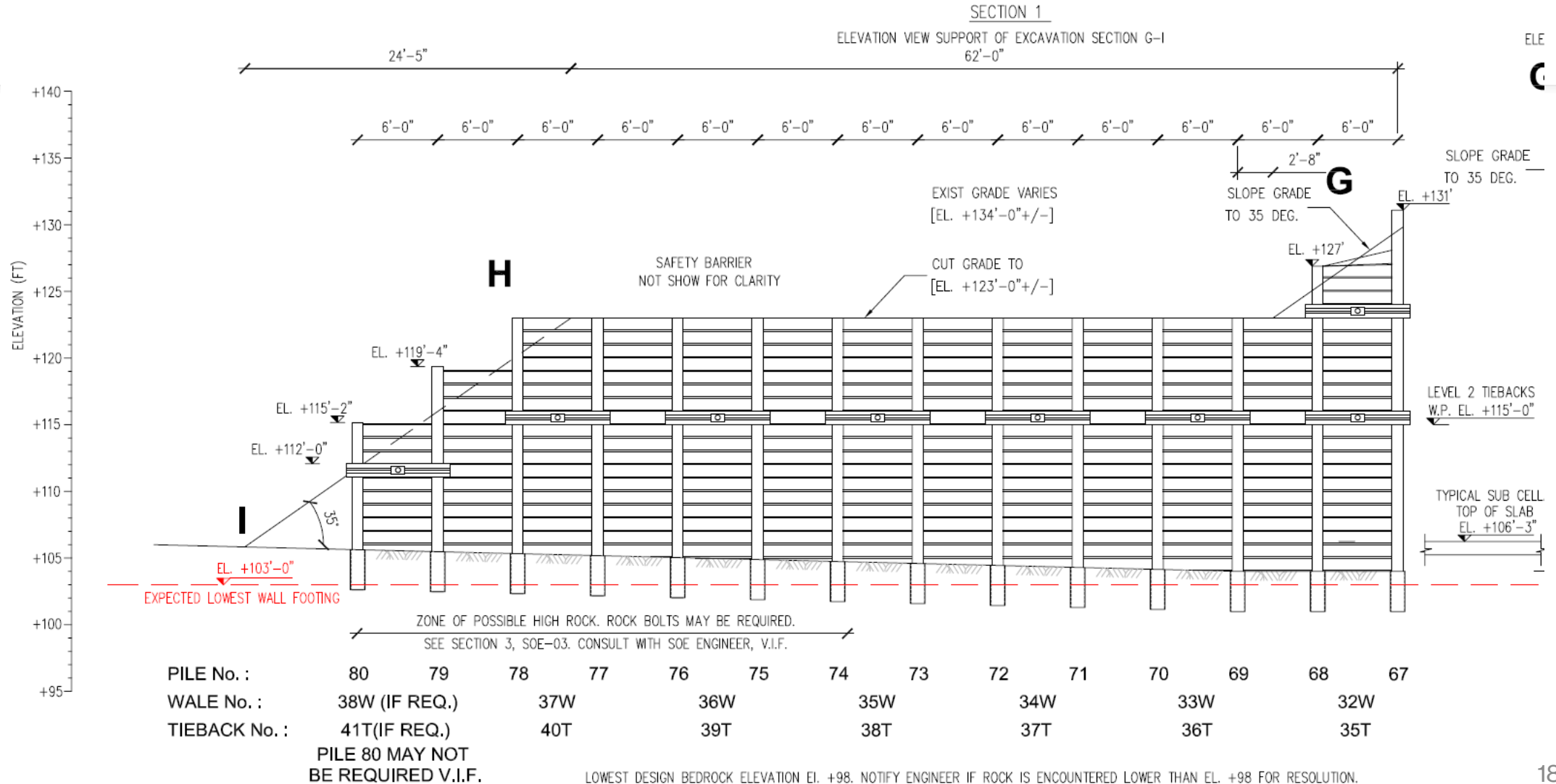

ELE

C

9.0.4 Double channel walers

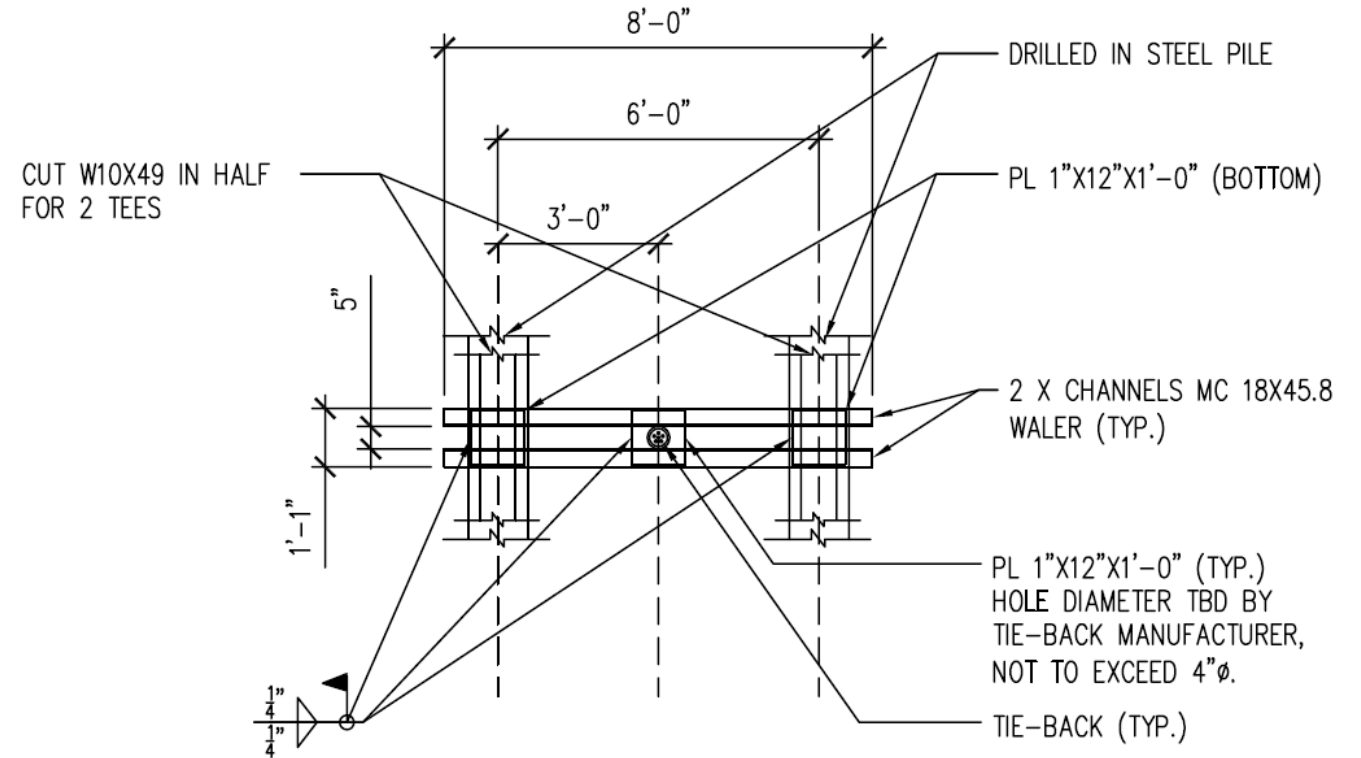
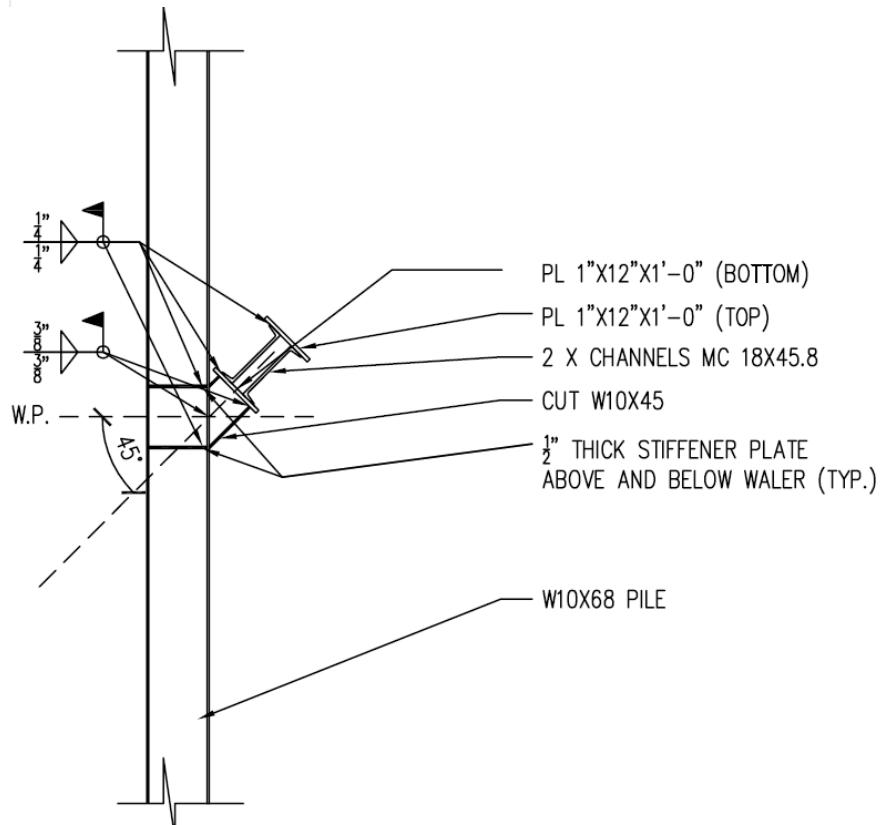



9.0.5 Tieback through W waler

- W walers may be used as walers for tiebacks
- Need to cut hole through web, flange, or both
- Cut hole reduces section modulus of waler

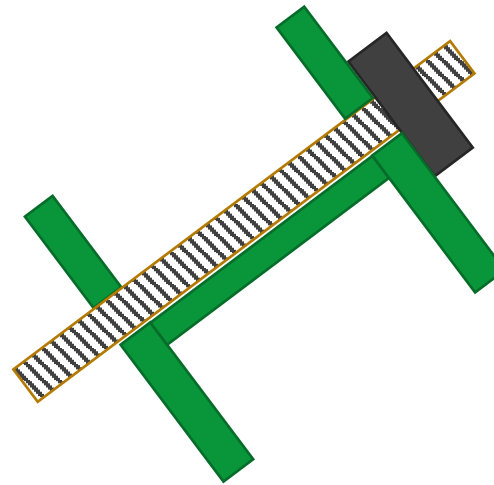
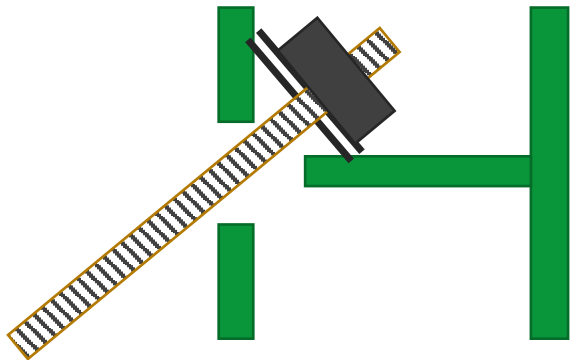

9.0.6 Tiebacks through W walers

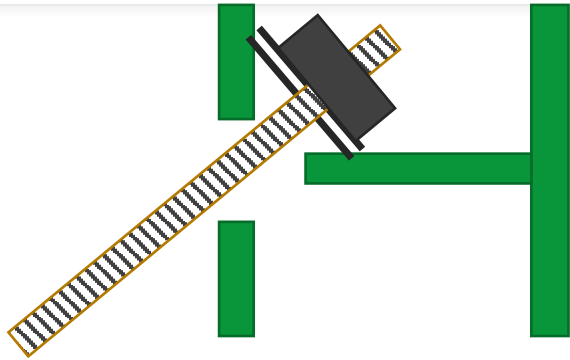

- Greater loss of section due to flange.
- Easier to connect to pile

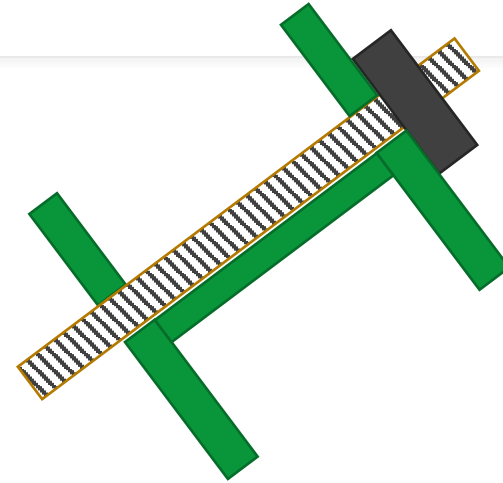

- Smaller loss of section due to smaller holes at flange.
- Requires connection bracket to connect to pile

9.0.7 Example Tiebacks through W walers

Calculate Moment of Inertia and Section Modulus of the two W walers cases.

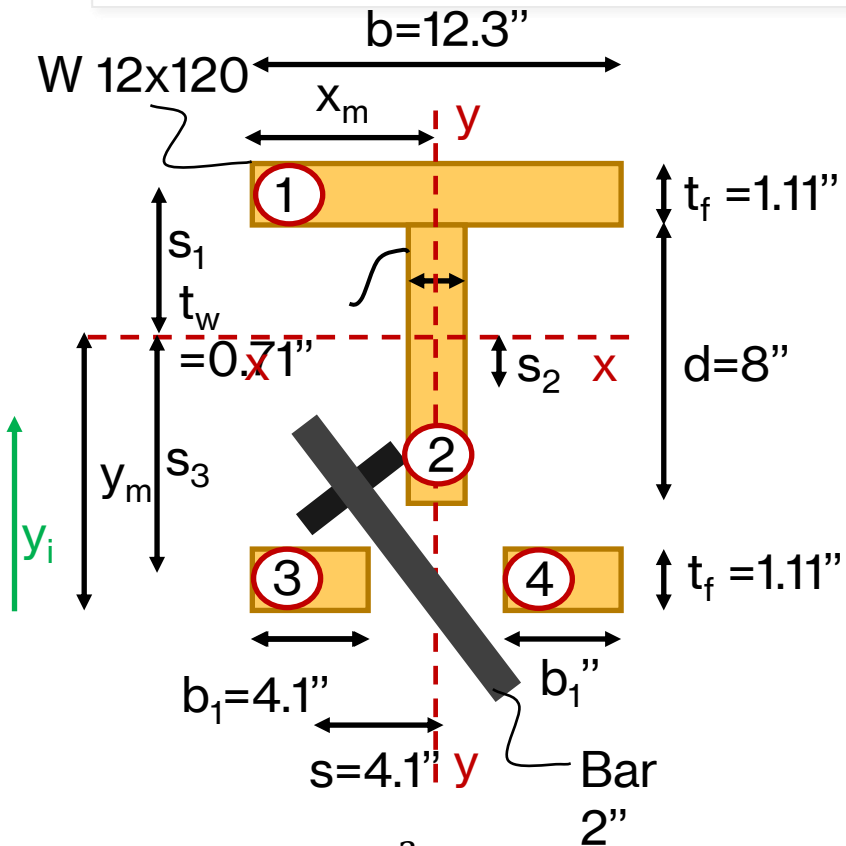

$$S_{xx} = 163 \text{ in}^3$$

$$S_{yy} = 56 \text{ in}^3$$

Bending y-y

Calculation of x_m (position of y-y axis)
 $x_m = b/2 = 6.15''$ (symmetry)

Modulus of Elasticity

$$I_y = I_{y,1} + I_{y,2} + I_{y,3} + I_{y,4}$$

$$I_{y,1} = \frac{t_f \cdot b^3}{12} = 172.13 \text{ in}^4$$

$$I_{y,2} = \frac{d \cdot t_w^3}{12} = 0.239 \text{ in}^4$$

$$I_{y,3} = I_{y,4} = \frac{t_f \cdot b_1^3}{12} + t_f \cdot b_1 \cdot s^2 = 82.877 \text{ in}^4$$

$$\text{So, } I_y = 338.123 \text{ in}^4$$

Section Modulus:

$$S_{yy} = \frac{I_y}{b/2} = 54.98 \text{ in}^3$$

Bending x-x

Calculation of y_m (position of x-x axis)
 $y_m = \frac{A_1 y_1 + A_2 y_2 + A_3 y_3 + A_4 y_4}{A_1 + A_2 + A_3 + A_4} = 7.82''$

Modulus of Elasticity

$$I_x = I_{x,1} + I_{x,2} + I_{x,3} + I_{x,4}$$

$$I_{x,1} = \frac{b \cdot t_f^3}{12} + t_f \cdot b \cdot s_1^2 = 304.071 \text{ in}^4$$

$$I_{x,2} = \frac{t_w \cdot d^3}{12} + t_w \cdot d \cdot s_2^2 = 113.178 \text{ in}^4$$

$$I_{x,3} = I_{x,4} = \frac{b_1 \cdot t_f^3}{12} + t_f \cdot b_1 \cdot s_3^2 = 238.821 \text{ in}^4$$

$$\text{So, } I_x = 656.07 \text{ in}^4$$

Section Modulus:

$$S_{xx} = \frac{I_x}{y_m} = 83.896 \text{ in}^3$$

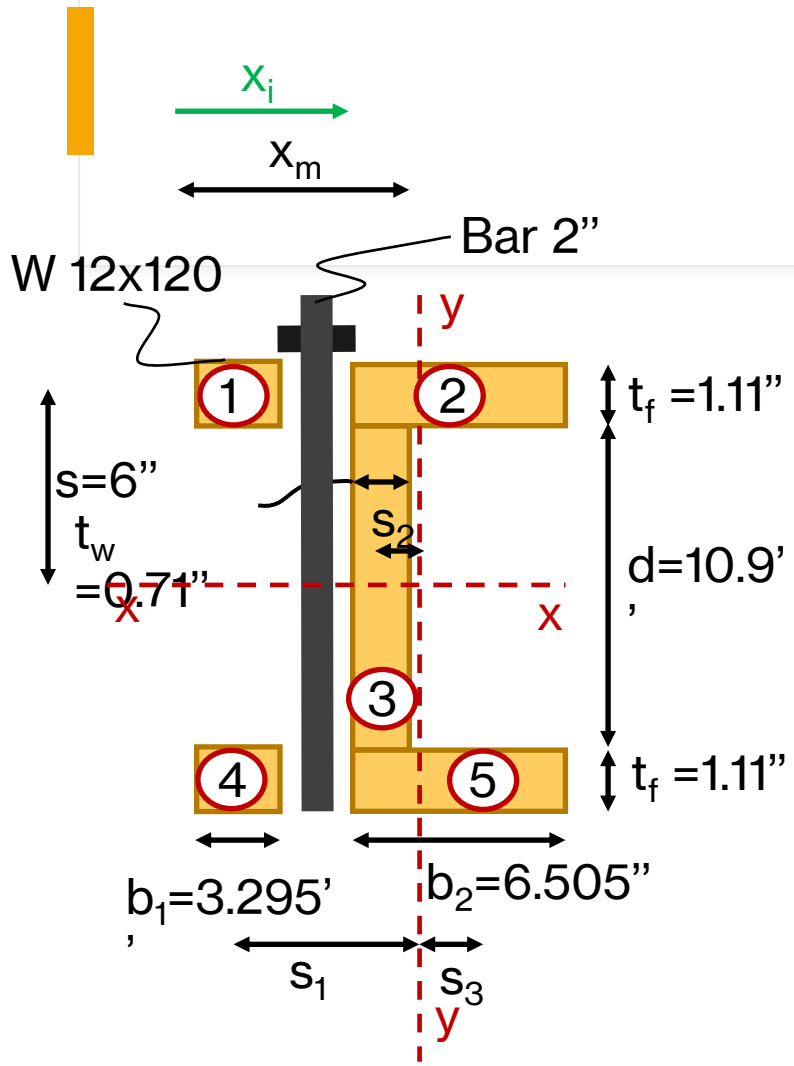

$$S_{xx} = 163 \text{ in}^3$$

$$S_{yy} = 56 \text{ in}^3$$

Bending y-y

Calculation of x_m (position of y-y axis)

$$x_m = \frac{A_1 x_1 + A_2 x_2 + A_3 x_3 + A_4 x_4}{A_1 + A_2 + A_3 + A_4} = 6.284''$$

Modulus of Elasticity

$$I_y = I_{y,1} + I_{y,2} + I_{y,3} + I_{y,4} + I_{y,5}$$

$$I_{y,1} = I_{y,4} = \frac{t_f \cdot b_1^3}{12} + t_f \cdot b_1 \cdot s_1^2 = 81.934 \text{ in}^4$$

$$I_{y,3} = \frac{d \cdot t_w^3}{12} + d \cdot t_w \cdot s_2^2 = 0.464 \text{ in}^4$$

$$I_{y,2} = I_{y,5} = \frac{t_f \cdot b_2^3}{12} + t_f \cdot b_2 \cdot s_3^2 = 80.604 \text{ in}^4$$

$$\text{So, } I_y = 325.54 \text{ in}^4$$

Section Modulus:

$$S_{yy} = \frac{I_y}{x_m} = 51.8 \text{ in}^3$$

Bending x-x

Calculation of y_m (position of x-x axis)

$$y_m = D/2 = 6.55'' \text{ (symmetry)}$$

Modulus of Elasticity

$$I_x = I_{x,1} + I_{x,2} + I_{x,3} + I_{x,4} + I_{x,5}$$

$$I_{x,1} = I_{x,4} = \frac{b_1 \cdot t_f^3}{12} + t_f \cdot b_1 \cdot s^2 = 132.044 \text{ in}^4$$

$$I_{x,3} = \frac{t_w \cdot d^3}{12} = 76.623 \text{ in}^4$$

$$I_{x,2} = I_{x,5} = \frac{b_2 \cdot t_f^3}{12} + t_f \cdot b_2 \cdot s^2 = 260.681 \text{ in}^4$$

$$\text{So, } I_x = 862.073 \text{ in}^4$$

Section Modulus:

$$S_{xx} = \frac{I_x}{y_m} = 131.614 \text{ in}^3$$

9.0.10 Pipe hole through soldier pile

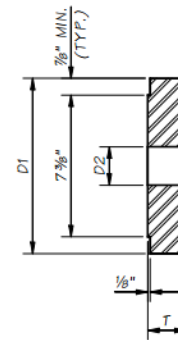
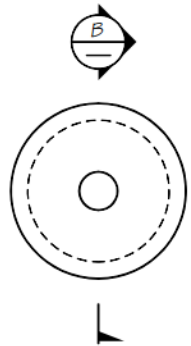
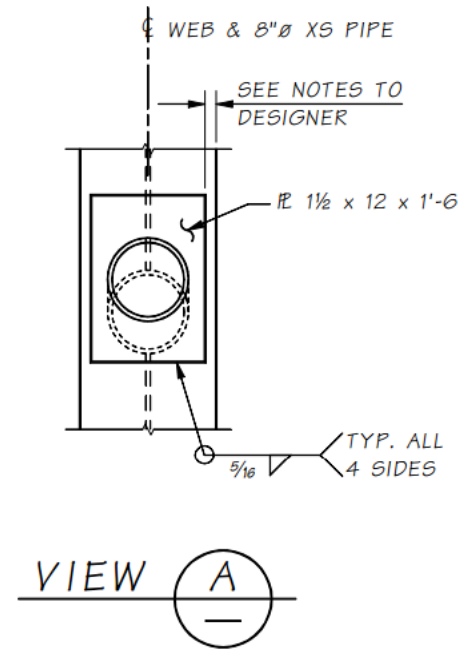
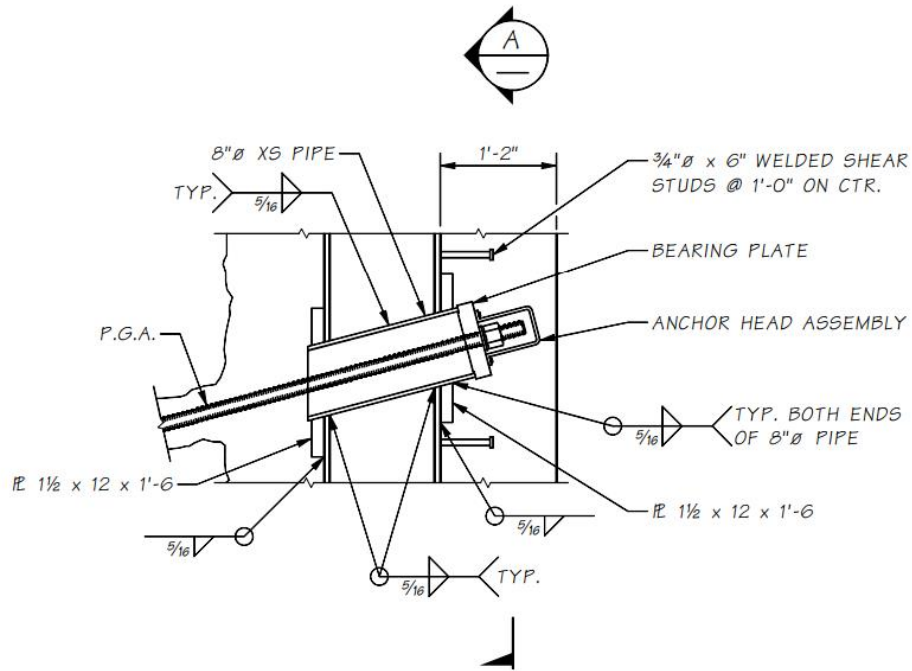

9.1 Trick of the trade (with walers and more)

- Need greater strength at specified location?
- Use web or flange plates

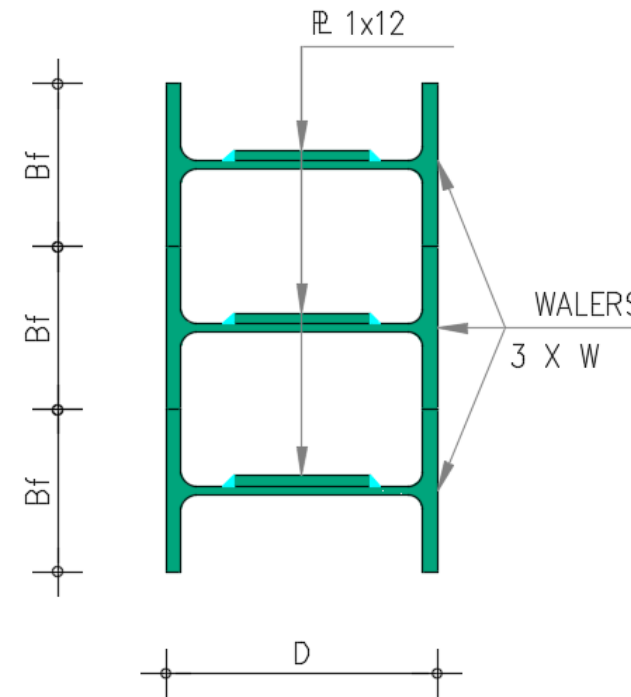
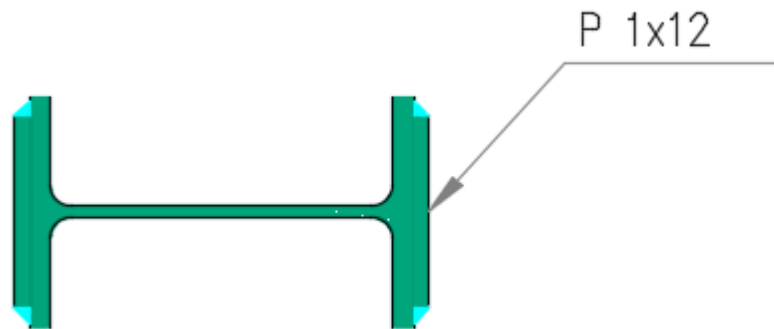

Quiz: Waler design - Torsion

You have a 70 ft wide sheet pile braced excavation supported by cross-lot struts, corner braces, and walers. The walers are welded on the sheet piles, and the struts and braces are welded on the walers without brackets. Should you consider torsion for the design of the walers?

- a) Yes, torsion should be considered
- b) No, torsion can be ignored

9.2 Flanges and Webs with Concentrated Forces

This applies to single- and double-concentrated forces applied normal to the flange(s) of wide flange sections and similar built-up shapes. A single-concentrated force can be either tensile or compressive. Double-concentrated forces are one tensile and one compressive and form a couple on the same side of the loaded member.

When the required strength exceeds the available strength as determined for the limit states listed in this section, stiffeners and/or doublers shall be provided and shall be sized for the difference between the required strength and the available strength for the applicable limit state. Stiffeners are required at unframed ends of beams.

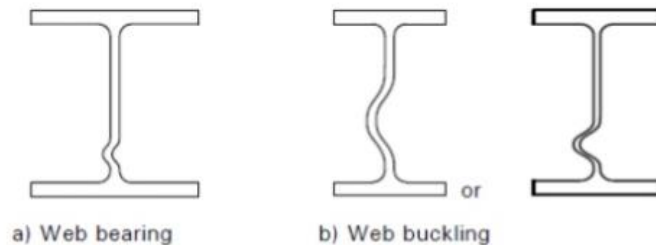

9.3.1 Flange Local Bending

This applies to tensile single-concentrated forces and the tensile component of double-concentrated forces.

The design strength, ϕR_n , and the allowable strength, R_n/Ω , for the limit state of flange local bending shall be determined as follows:

$$R_n = 6.25 \cdot t_f^2 \cdot F_{yf}$$

$$\phi=0.90 \text{ (LRFD)} \quad \Omega=1.67 \text{ (ASD)}$$

where: F_{yf} = Specified minimum yield stress of the flange

t_f = Thickness of the loaded flange

If the length of loading across the member flange is less than $0.15 \cdot b_f$, where b_f is the member flange width, the previous equation need not be checked.

When the concentrated force to be resisted is applied at a distance from the member end that is less than $10 \cdot t_f$, R_n shall be reduced by 50 percent.

When required, a pair of transverse stiffeners shall be provided.

9.3.2 Web Local Yielding

This applies to single-concentrated forces and both components of double-concentrated forces.

The available strength for the limit state of web local yielding shall be determined as follows:

$$\phi=1.00 \text{ (LRFD)} \qquad \Omega=1.50 \text{ (ASD)}$$

The nominal strength, R_n , shall be determined as follows:

i. When the concentrated force to be resisted is applied at a distance from the member end that is greater than the depth of the member d :

$$R_n = (5 \cdot k + N) \cdot t_w \cdot F_{yw}$$

ii. When the concentrated force to be resisted is applied at a distance from the member end that is less than or equal to the depth of the member d

$$R_n = (2.5 \cdot k + N) \cdot t_w \cdot F_{yw}$$

where: F_{yf} = Specified minimum yield stress of the web

t_w = Web thickness

k = distance from outer face of the flange to the web toe of the fillet

N = length of bearing (not less than k for end beam reactions)

When required, a pair of transverse stiffeners or a doubler plate shall be provided.

9.3.3 Web Local Crippling

This applies to compressive single-concentrated forces or the compressive component of double-concentrated forces.

The available strength for the limit state of web local crippling shall be determined as follows:

$$\phi=0.75 \text{ (LRFD)} \quad \Omega=2.00 \text{ (ASD)}$$

The nominal strength, R_n , shall be determined as follows:

i. When the concentrated compressive force to be resisted is applied at a distance from the member end that is greater than or equal to $d/2$:

$$R_n = 0.80 \cdot t_w^2 \cdot \left[1 + 3 \cdot \left(\frac{N}{d} \right) \cdot \left(\frac{t_w}{t_f} \right)^{1.5} \right] \cdot \sqrt{\frac{E \cdot t_f \cdot F_{yw}}{t_w}}$$

ii. When the concentrated compressive force to be resisted is applied at a distance from the member end that is less than $d/2$:

For $N/d \leq 0.2$

$$R_n = 0.40 \cdot t_w^2 \cdot \left[1 + 3 \cdot \left(\frac{N}{d} \right) \cdot \left(\frac{t_w}{t_f} \right)^{1.5} \right] \cdot \sqrt{\frac{E \cdot t_f \cdot F_{yw}}{t_w}}$$

For $N/d > 0.2$

$$R_n = 0.40 \cdot t_w^2 \cdot \left[1 + \left(\frac{4N}{d} - 0.2 \right) \cdot \left(\frac{t_w}{t_f} \right)^{1.5} \right] \cdot \sqrt{\frac{E \cdot t_f \cdot F_{yw}}{t_w}}$$

where: d = Overall depth of the member

t_f = Flange thickness

When required, a transverse stiffener, or pair of transverse stiffeners, or a doubler plate extending at least one-half the depth of the web shall be provided.

9.3.4 Web Sideway Buckling

This applies only to compressive single-concentrated forces applied to members where relative lateral movement between the loaded compression flange and the tension flange is not restrained at the point of application of the concentrated force.

$$\phi=0.85 \text{ (LRFD)}$$

$$\Omega=1.76 \text{ (ASD)}$$

The available strength of the web shall be determined as follows:

i. If the compression flange is restrained against rotation:

For $(h/t_w)/(l/b_f) \leq 2.3$:

$$R_n = \frac{C_r \cdot t_w^3 \cdot t_f}{h^2} \cdot \left[1 + 0.4 \cdot \left(\frac{h/t_w}{l/b_f} \right)^3 \right]$$

For $(h/t_w)/(l/b_f) > 2.3$:

The limit state of web sideways buckling does not apply.

When the required strength of the web exceeds the available strength, local lateral bracing shall be provided at the tension flange or either a pair of transverse stiffeners or a doubler plate shall be provided.

ii. If the compression flange is not restrained against rotation:

For $(h/t_w)/(l/b_f) \leq 1.7$:

$$R_n = \frac{C_r \cdot t_w^3 \cdot t_f}{h^2} \cdot \left[0.4 \cdot \left(\frac{h/t_w}{l/b_f} \right)^3 \right]$$

For $(h/t_w)/(l/b_f) > 1.7$:

The limit state of web sideways buckling does not apply.

When the required strength of the web exceeds the available strength, local lateral bracing shall be provided at both flanges at the point of application of the concentrated forces.

In the above equations:

b_f = Flange width

t_f = Flange thickness

t_w = Web thickness

l = largest laterally unbraced length along either flange at the point of load

h = clear distance between flanges less the fillet or corner radius for rolled shapes; distance between adjacent lines of fasteners or the clear distance between flanges when welds are used for built-up shapes

C_r = 960,000 ksi when $M_u < M_y$ (LRFD) or $1.5M_a < M_y$ (ASD) at the location of the force
= 480,000 ksi when $M_u \geq M_y$ (LRFD) or $1.5M_a \geq M_y$ (ASD) at the location of the force

9.3.5 Web Compression Buckling

This applies to a pair of compressive single-concentrated forces or the compressive components in a pair of double-concentrated forces, applied at both flanges of a member at the same location.

The available strength for the limit state of web local buckling shall be determined as follows:

$$\phi=0.90 \text{ (LRFD)} \quad \Omega=1.67 \text{ (ASD)}$$

$$R_n = \frac{24 \cdot t_w^3 \cdot \sqrt{E \cdot F_{yw}}}{h}$$

When the pair of concentrated compressive forces to be resisted is applied at a distance from the member end that is less than $d/2$, R_n shall be reduced by 50 percent.

When required, a single transverse stiffener, a pair of transverse stiffeners, or a doubler plate extending the full depth of the web shall be provided.

9.3.6 Web Panel Zone Shear

This section applies to double-concentrated forces applied to one or both flanges of a member at the same location.

The available strength of the web panel zone for the limit state of shear yielding shall be determined as follows: $\phi=0.85$ (LRFD) $\Omega=1.76$ (ASD)

i. When the effect of panel-zone deformation on frame stability is not considered in the analysis:

For $P_r \leq 0.4 \cdot P_c$:

$$R_n = 0.60 \cdot F_y \cdot d_c \cdot t_w$$

For $P_r > 0.4 \cdot P_c$:

$$R_n = 0.60 \cdot F_y \cdot d_c \cdot t_w \cdot \left(1.4 - \frac{P_r}{P_c} \right)$$

ii. When frame stability, including plastic panel-zone deformation, is considered in the analysis:

For $P_r \leq 0.75 \cdot P_c$:

$$R_n = 0.60 \cdot F_y \cdot d_c \cdot t_w \cdot \left(1 + \frac{3 \cdot b_{cf} \cdot t_{cf}^2}{d_b \cdot d_c \cdot t_w} \right)$$

For $P_r > 0.75 \cdot P_c$:

$$R_n = 0.60 \cdot F_y \cdot d_c \cdot t_w \cdot \left(1 + \frac{3 \cdot b_{cf} \cdot t_{cf}^2}{d_b \cdot d_c \cdot t_w} \right) \cdot \left(1.9 - \frac{1.2 \cdot P_r}{P_c} \right)$$

When required, doubler plate(s) or a pair of diagonal stiffeners shall be provided within the boundaries of the rigid connection whose webs lie in a common plane.

In the above equations:

A = column cross-sectional area

b_{cf} = width of column flange

d_b = Beam depth

d_c = Column depth

F_c = specified minimum yield stress of the column web

$P_c = P_y$ (LRFD)

$P_c = 0.6 \cdot P_y$ (ASD)

P_r = Required strength

$P_y = F_y \cdot A$ = axial yield strength of the column

t_{cf} = thickness of the column flange

t_w = column web thickness

9.3.7 Unframed Ends of Beams and Girders

- At unframed ends of beams and girders not otherwise restrained against rotation about their longitudinal axes, a pair of transverse stiffeners, extending the full depth of the web, shall be provided.



9.3.8 Additional Stiffener Requirements for Concentrated Forces

Stiffeners required to resist tensile concentrated forces shall be designed in accordance with the requirements of Chapter D and welded to the loaded flange and the web. The welds to the flange shall be sized for the difference between the required strength and available limit state strength. The stiffener to web welds shall be sized to transfer to the web the algebraic difference in tensile force at the ends of the stiffener.

Stiffeners required to resist compressive concentrated forces either bear on or be welded to the loaded flange and welded to the web. The welds to the flange shall be sized for the difference between the required strength and the applicable limit state strength. The weld to the web shall be sized to transfer to the web the algebraic difference in compression force at the ends of the stiffener.

The member properties shall be determined using an effective length of $0.75 \cdot h$ and a cross section composed of two stiffeners and a strip of the web having a width of $25 \cdot t_w$ at interior stiffeners and $12 \cdot t_w$ at the ends of members. The weld connecting full depth bearing stiffeners to the web shall be sized to transmit the difference in compressive force at each of the stiffeners to the web.

Transverse and diagonal stiffeners shall comply with the following additional criteria:

- i. The width of each stiffener plus one-half the thickness of the column web shall not be less than one-third of the width of the flange or moment connection plate delivering the concentrated force.
- ii. The thickness of a stiffener shall not be less than one-half the thickness of the flange or moment connection plate delivering the concentrated load, and greater than or equal to the width divided by 15.
- iii. Transverse stiffeners shall extend a minimum of one-half the depth of the member except as required in sections 3.8.5 and 3.8.7 above.

9.3.9 Additional Doubler Plate Requirements for Concentrated Forces

Doubler plates shall comply with the following criteria:

- i. The thickness and extent of the doubler plate shall provide the additional material necessary to equal or exceed the strength requirements.
- ii. The doubler plate shall be welded to develop the proportion of the total force transmitted to the doubler plate.

Quiz: Corner waler connections

You have a 90 degree corner wale to wale connection with W24x120 beams. Should you specify web stiffeners plates?

- a) Yes
- b) No



8.4.1 Steel Connections Done Wrong #1

- Nicoll highway collapse



J. Endicott, 2004

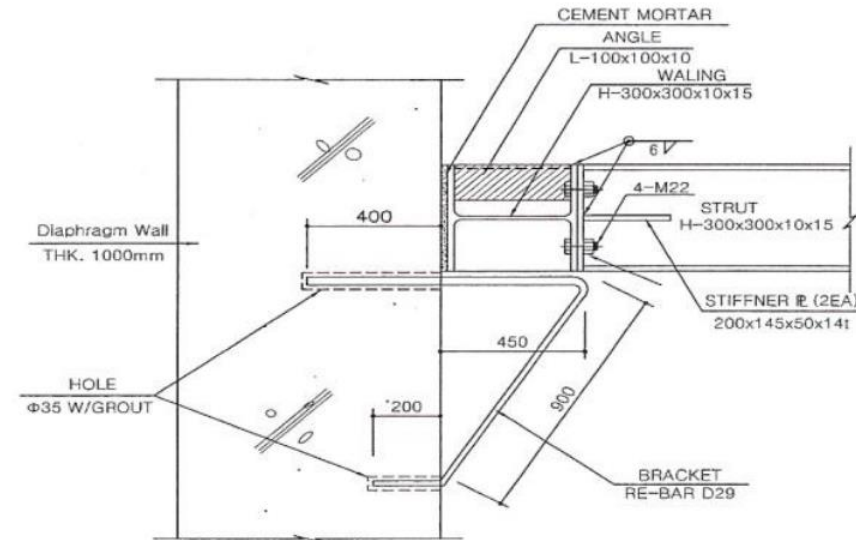

9.4.2 Steel Connections Done Wrong #2

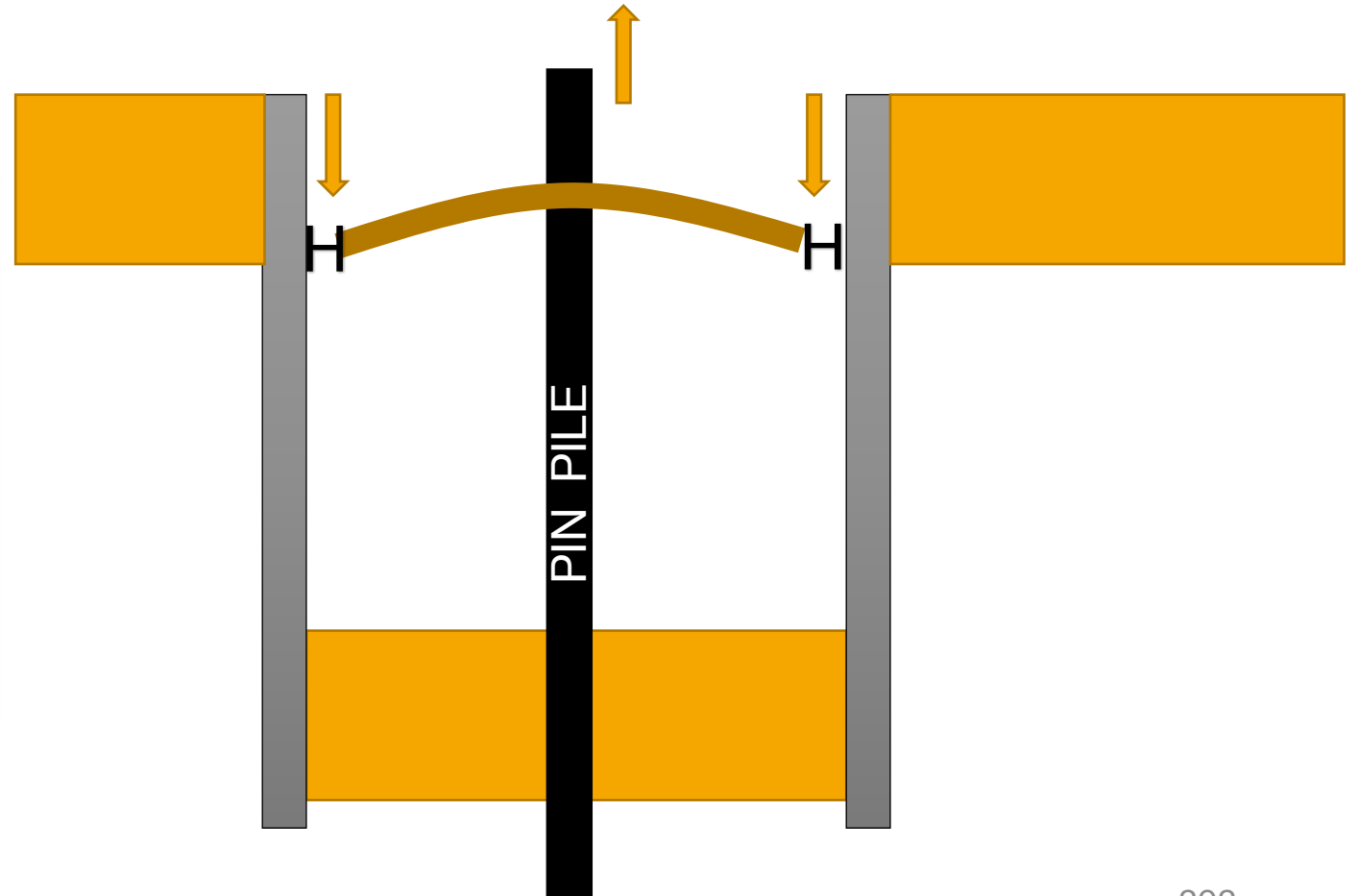
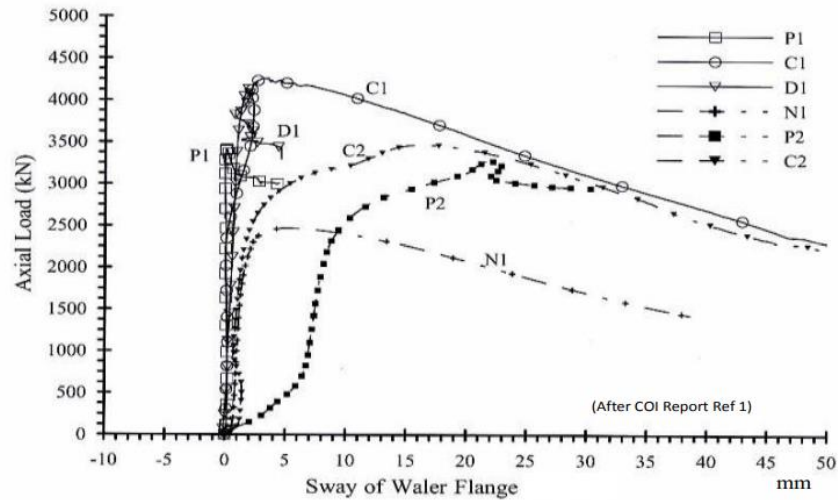



9.4.3 Steel Connection Gone Wrong #2

14th & H Streets, Washington DC, 1990

9.4.4 Steel Connections Gone Wrong #2

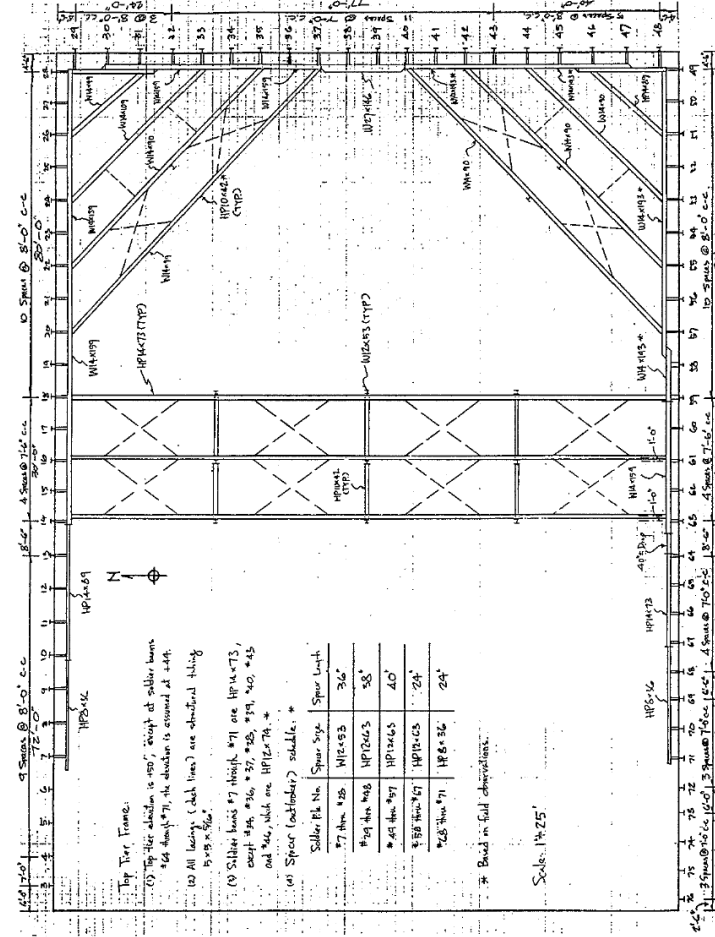
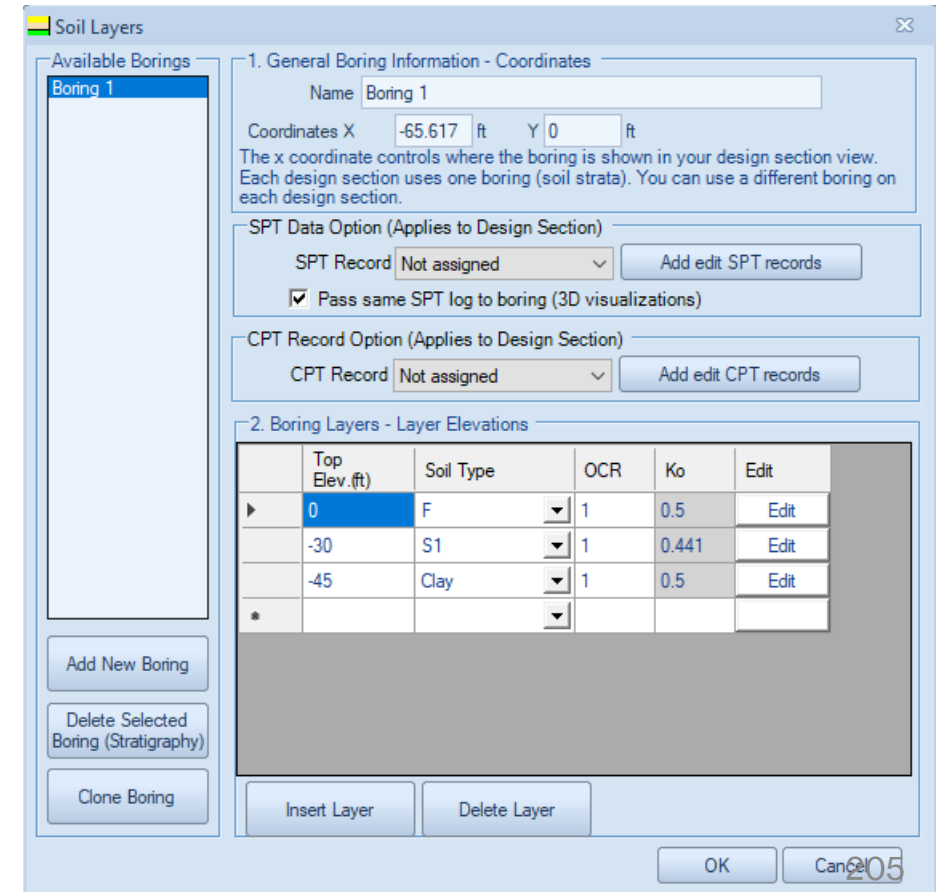
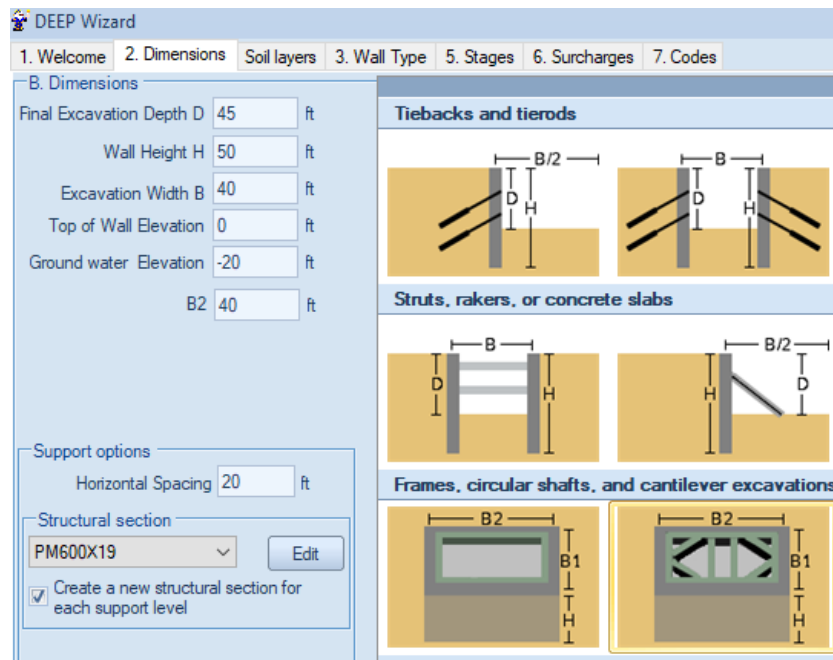

Figure 3.45 As-built Condition of the Top Tier Internal Support System.

9.5.1 Steel Connection Example

- Create deep excavation box 40ft x 40ft, sheet piles
- 35 ft deep, one support at -10ft



9.5.2 Steel Connection Example

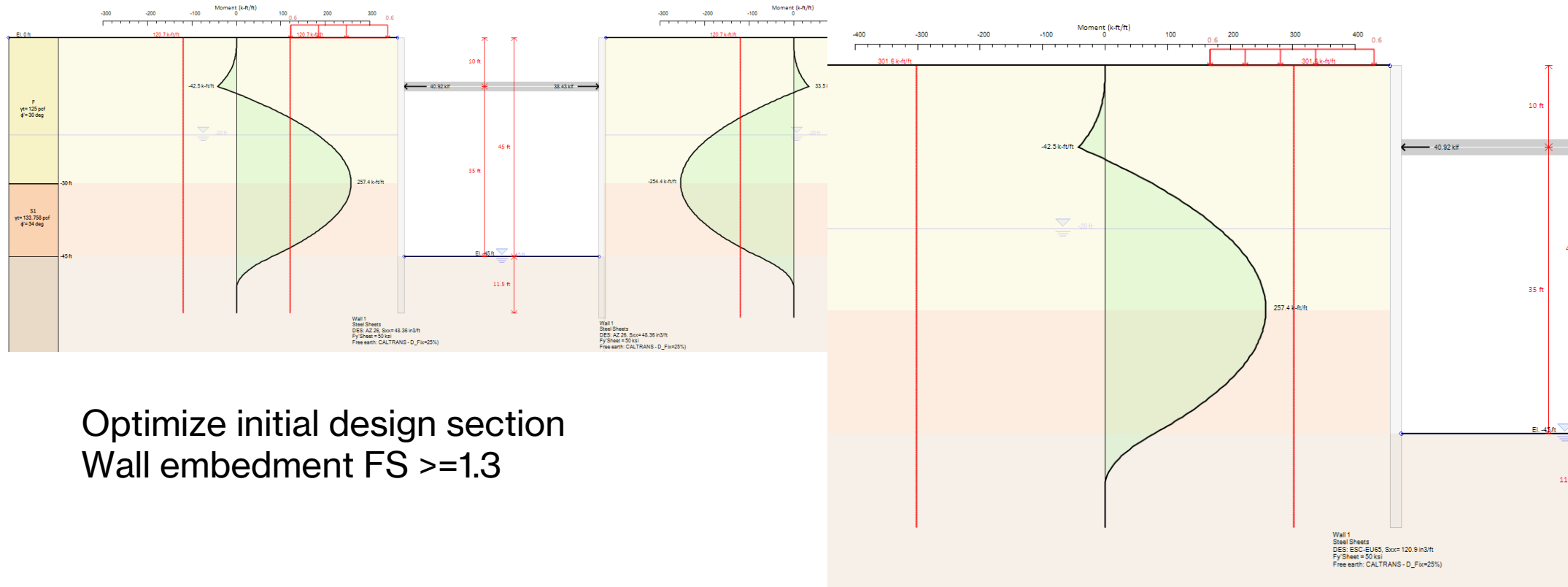

Optimize initial design section
Wall embedment FS ≥ 1.3

9.5.3 Steel Connections – Top View

- Resize excavation for sheet pile sizes

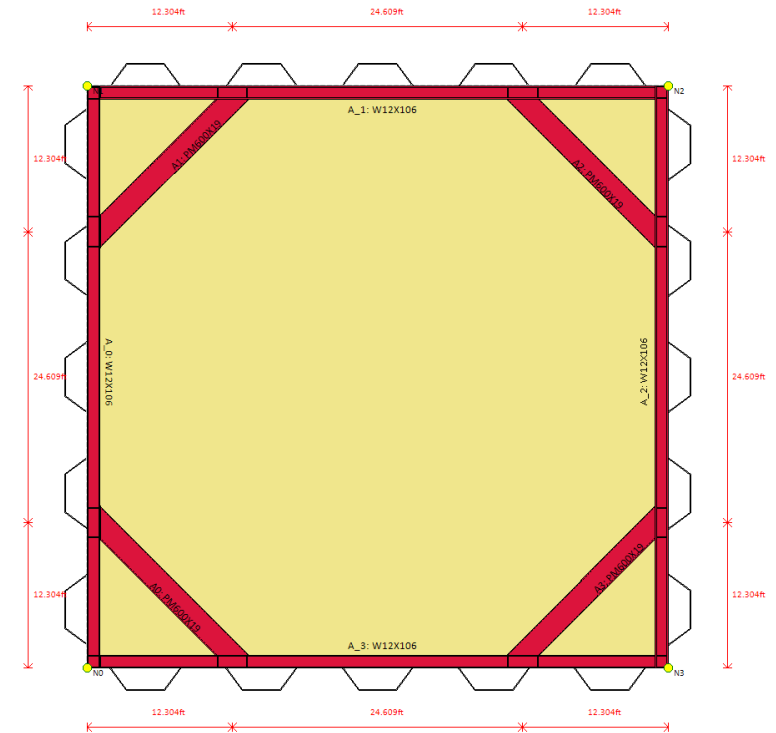
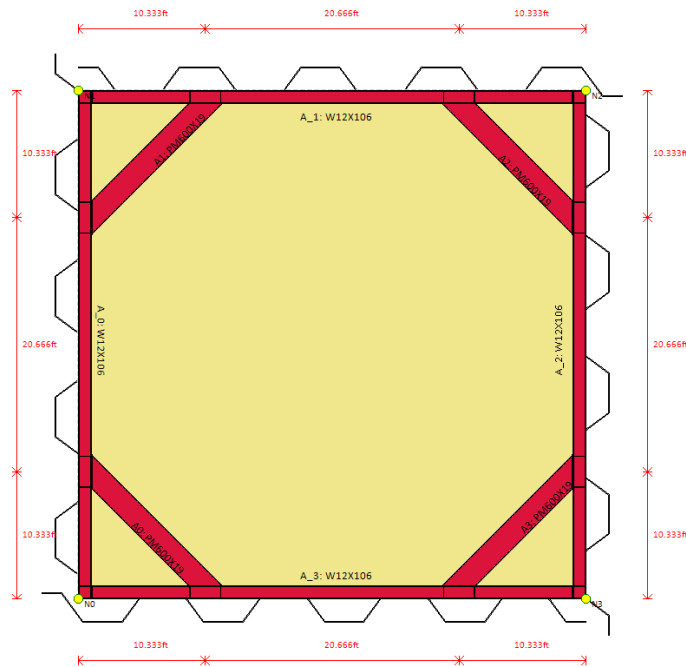
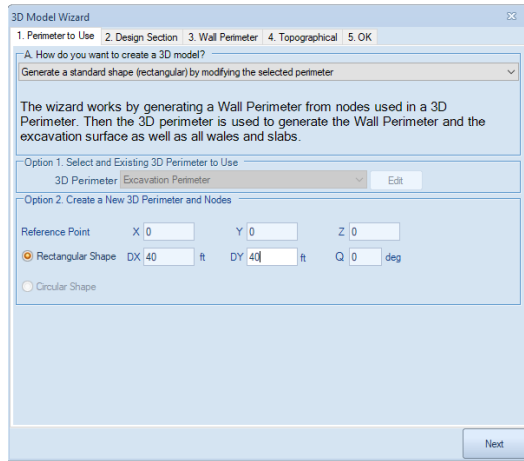

9.5.4 Optimize Walers and Braces

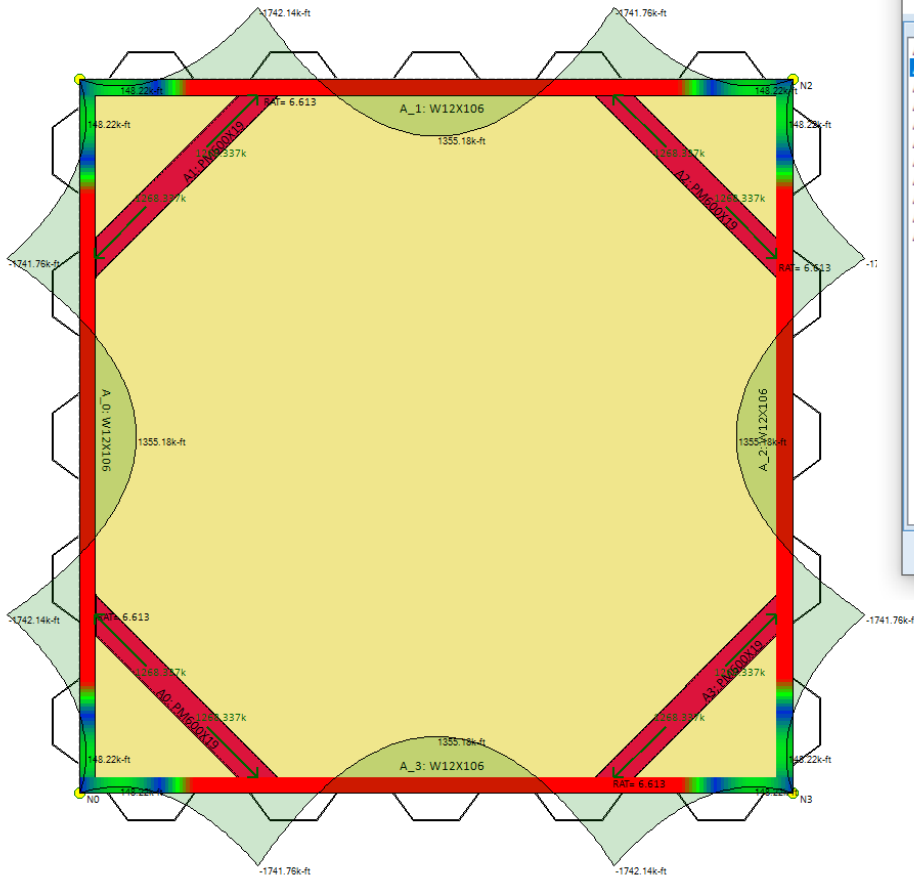

Optimize waler beam A_0 at El. -10ft

Please select from the available list

Area= 104 in ² : W33x354, Stress check= 0.999
Area= 106 in ² : W36x361, Stress check= 0.941
Area= 107 in ² : W40x362, Stress check= 0.958
Area= 109 in ² : W40x372, Stress check= 0.937
Area= 114 in ² : W33x387, Stress check= 0.906
Area= 115 in ² : W30x391, Stress check= 0.941
Area= 116 in ² : W36x395, Stress check= 0.851
Area= 117 in ² : W40x397, Stress check= 0.866
Area= 127 in ² : W40x431, Stress check= 0.795
Area= 130 in ² : W36x441, Stress check= 0.756
Area= 143 in ² : W36x487, Stress check= 0.68

Optimize strut A0 with length L= 15.879ft

Please select from the available list

Area= 44.33 in ² : PP38x0.375, Stress check= 0.974
Area= 45.36 in ² : PP20x0.75, Stress check= 0.995
Area= 45.9 in ² : PP24x0.625, Stress check= 0.965
Area= 46.34 in ² : PP30x0.5, Stress check= 0.941
Area= 46.68 in ² : PP40x0.375, Stress check= 0.923
Area= 47.07 in ² : PP18x0.875, Stress check= 0.974
Area= 47.12 in ² : PP16x1, Stress check= 0.996
Area= 49.04 in ² : PP42x0.375, Stress check= 0.878
Area= 49.48 in ² : PP32x0.5, Stress check= 0.879
Area= 49.82 in ² : PP26x0.625, Stress check= 0.884
Area= 50.07 in ² : PP22x0.75, Stress check= 0.892

9.5.6 Optimized Bracing (not connections)

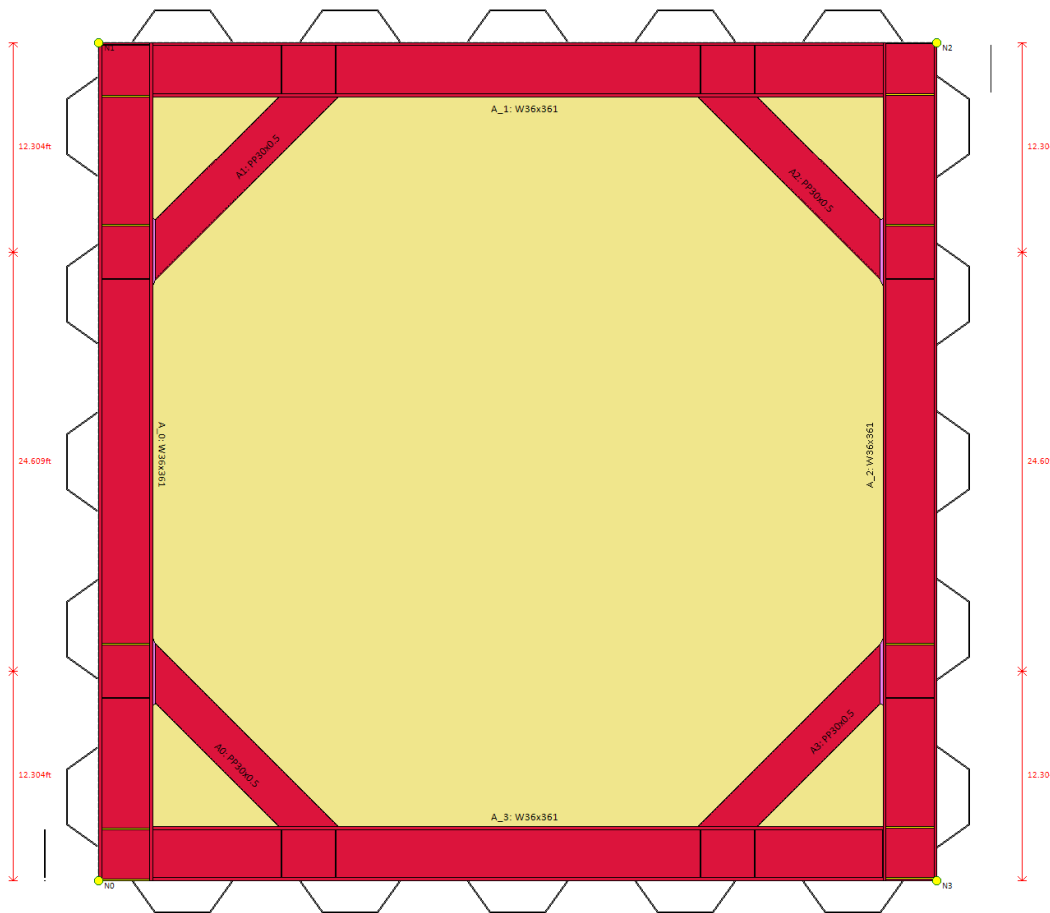

Steel Connection Data

Name and section type: Name: WALE: A_0-STRUT: A1, Stiffener status: []

Horizontal angle: 45 deg, Max. weld stress check (all stages): []

Input Stage Results

Connection Options: Weld Size: 0.5 in

Connection Stub: Type: Use H (or W) beam stub, Stub section: W40x199, Min. overlap with strut: 24 in, Weld (pipe to connector): 0.5000 in

Selected Welds: [Diagram of H-section with welds]

Stiffener Name	Location	Thick (in)	Height (in)	Width (in)
PL1_T	Top	0.75	5.7955	10.929
PL1_B	Bottom	0.75	5.7955	10.929
PL2_T	Top	0.75	5.7955	10.929
PL2_B	Bottom	0.75	5.7955	10.929

Weld Size: 0.375 in, Remove stiffeners: []

[x] Match changes to similar steel connections

OK Cancel

9.5.7 Steel Connection Results

3D Frame Calculation Summary

Summary | Wale results | Strut results | Cost estimate

Select

Show all items | Show only selected elevation | Elev. -10

Results for walers (3D)

Name	Elev. (ft)	Moment (k-ft)	Shear (k)	Axial (k)	RAT	RAT M	RAT V	Length (ft)	Weight (k)	Section
A_0	-10	1742.34	503.49	1006.96	0.941	0.941	0.736	49.217	17.7673	W36x361
A_1	-10	1742.34	503.49	1006.96	0.941	0.941	0.736	49.217	17.7673	W36x361
A_2	-10	1742.34	503.49	1006.96	0.941	0.941	0.736	49.217	17.7673	W36x361
A_3	-10	1742.34	503.49	1006.96	0.941	0.941	0.736	49.217	17.7673	W36x361

Results for steel connections (walers to struts)

WALE	Waler	Strut	Weld size (in)	Weld Length (in)	Stiffeners	RAT Welds	RAT Stiffeners	Base-PL	Base-PL Welds (in)	R B W
WALE_A_0-STRUT_A0	A_0	A0	0.5	91.266	4x7.79x...	1.333	0.781	N/A	N/A	N
WALE_A_3-STRUT_A0	A_3	A0	0.5	91.266	4x7.79x...	1.333	0.781	N/A	N/A	N
WALE_A_0-STRUT_A1	A_0	A1	0.5	91.266	4x5.796...	1.333	0.925	N/A	N/A	N
WALE_A_1-STRUT_A1	A_1	A1	0.5	91.266	4x7.79x...	1.333	0.781	N/A	N/A	N
WALE_A_2-STRUT_A2	A_2	A2	0.5	91.266	4x7.79x...	1.333	0.781	N/A	N/A	N
WALE_A_1-STRUT_A2	A_1	A2	0.5	91.266	4x7.79x...	1.333	0.781	N/A	N/A	N
WALE_A_2-STRUT_A3	A_2	A3	0.5	91.266	4x7.79x...	1.333	0.781	N/A	N/A	N
WALE_A_3-STRUT_A3	A_3	A3	0.5	91.266	4x7.79x...	1.333	0.781	N/A	N/A	N
A_1to-A_0	A_0	A_1	0.25	59.56	4x7.79x...	0.461	0		N/A	N
A_1to-A_2	A_2	A_1	0.1875	59.56	4x7.79x...	0.116	0		N/A	N
A_3to-A_2	A_2	A_3	0.25	59.56	4x7.79x...	0.461	0		N/A	N
A_3to-A_0	A_0	A_3	0.1875	59.56	4x7.79x...	0.116	0		N/A	N

Results for struts and anchors (3D)

Results for struts (3D)

Name	Length (ft)	Moment (k-ft)	Axial force (k)	RAT	Weight (k)	Section
A0	12.922	3.29	1268.34	0.932	2.0376	PP30x0....
A1	12.922	3.29	1268.34	0.932	2.0376	PP30x0....
A2	12.922	3.29	1268.34	0.932	2.0376	PP30x0....

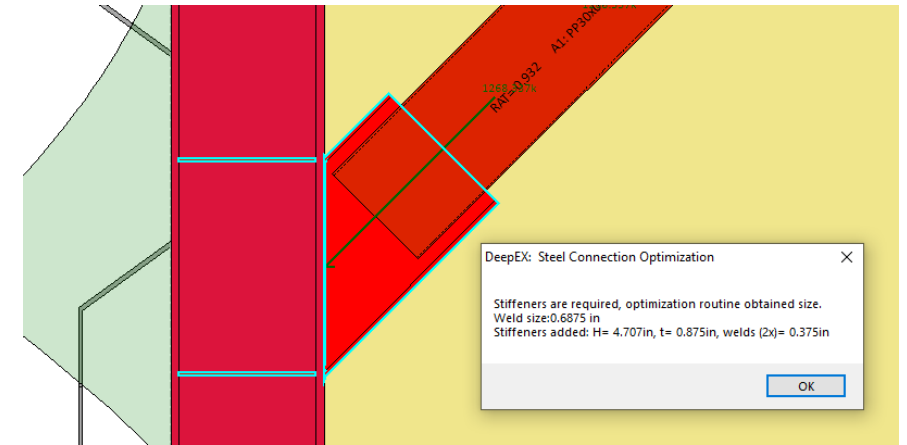
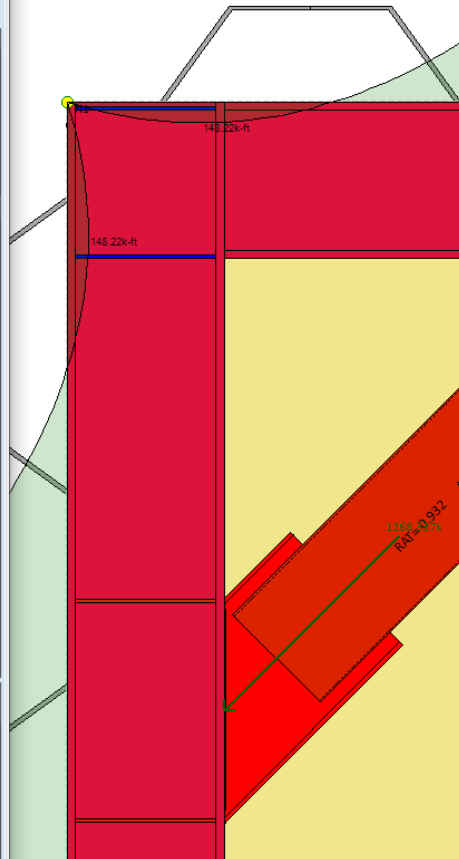

DeepEX: Steel Connection Optimization

Stiffeners are required, optimization routine obtained size.
 Weld size: 0.6875 in
 Stiffeners added: H= 4.707in, t= 0.875in, welds (2x)= 0.375in

OK

9.5.8 Sample Steel Connection Results

Steel Connection Data

Name and section type
Name: WALE: A_0-STRUT: A1
Horizontal angle: 45 deg
Max. weld stress check (all stages): 0.969

Stiffeners are required.
Provided stiffeners are adequate.

Input Stage Results

Equation	Provided Resistance	Required Tension Stiffener Force	Required Compression Stiffener Force	Stiffeners Required
LRFD J1...	0	0	0	N/A
LRFD J1...	0	0	0	N/A
LRFD J1...	276.27	0	173.03	Yes
LRFD J1...	0	0	0	N/A
LRFD J1...	404.71	0	44.59	Yes
LRFD J1...	0	0	0	N/A
LRFD J1...	0	0	0	N/A
LRFD J1...	0	0	0	N/A
LRFD J1...	757.88	0	0	No
Panel W...	764.55	0	0	No

Strut Weld Results

	Units	Value	Max. Permitted	Min. Required
Weld size	(in)	0.6875	N/A	0.6664
Stress at welds	(ksi)	14.391	14.847	N/A
Sox.Welds	in3	943.99		
Syy.Welds	in3	64.27		

Weld stress check: 0.969

Stub results

	Units	Value	Stress Check
Axial Strength	(k)	753.27	1.684
Shear strength (along welds)	(k)	561.6	2.258
Weld strength strength	(k)	1386	0.915

Stiffener strengths reported below for two stiffeners (top and bottom)

Compression Stiffener Strength: 633.5 k
Tensile Stiffener Strength: 408.16 k

Stiffeners are adequate.

Match changes to similar steel connections

OK Cancel

Refresh

Steel Connection Data

Name and section type
Name: WALE: A_0-STRUT: A1
Horizontal angle: 45 deg
Max. weld stress check (all stages): 0.936

Stiffeners are required.
Provided stiffeners are adequate.

Input Stage Results

Connection Options
Weld Size: 0.8125 in

Selected Welds

Connection Stub
Type: Use H (or W) beam stub
Stub section: W40x327
Clearance to strut: 3 in
Min. overlap with strut: 40 in
Weld (pipe to connector): 0.4375 in

Stiffeners

Stiffener Name	Location	Thick (in)	Height (in)	Width (in)
PL1_T	Top	1.625	7.79	33.98
PL1_B	Bottom	1.625	7.79	33.98
PL2_T	Top	1.625	7.79	33.98
PL2_B	Bottom	1.625	7.79	33.98

Weld Size: 0.75 in

Remove stiffeners

Match changes to similar steel connections

OK Cancel

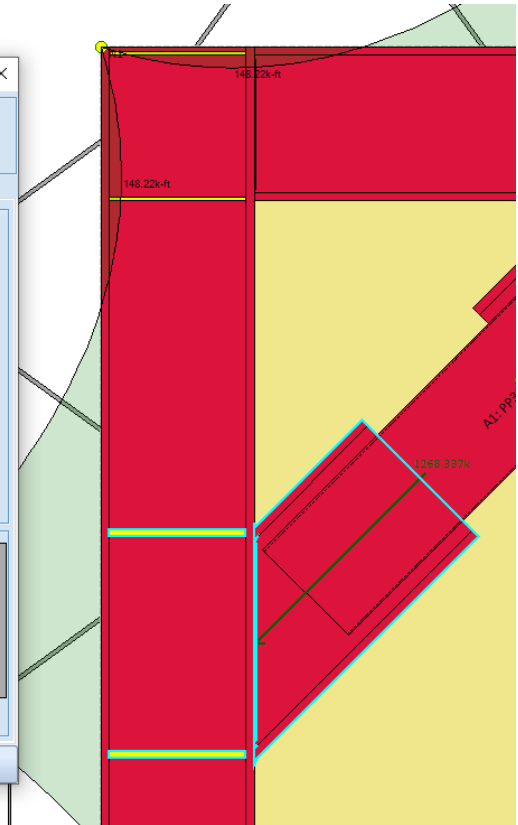

9.5.9 Knife Plate Connection

Name and section type

Name: WALE: A_0-STRUT: A1

Horizontal angle: 45 deg

Stiffener status:

Max. weld stress check (all stages):

Input: Stage Results

Connection Options

Weld Size: 0.6875 in

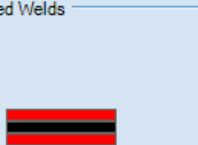
Selected Welds: 

Connection Stub

Type: Use knife plate

D: 50 in

T: 2 in

Min. overlap with strut: 24 in

Weld (pipe to connector): 0.375 in

Stiffeners

	Stiffener Name	Location	Thick (in)	Height (in)	Width (in)
▶	PL1_T	Top	0.875	7.79	33.98
	PL1_B	Bottom	0.875	7.79	33.98
	PL2_T	Top	0.875	7.79	33.98
	PL2_B	Bottom	0.875	7.79	33.98

Weld Size: 0.375 in

Remove stiffeners

Steel Connection Data

Name and section type

Name: WALE: A_0-STRUT: A1

Horizontal angle: 45 deg

Stiffeners are not required:

Max. weld stress check (all stages): 2.44

Input: Stage Results

Connection Options

Weld Size: 0.8125 in

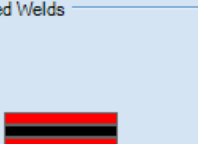
Selected Welds: 

Connection Stub

Type: Use knife plate

D: 50 in

T: 3 in

Clearance to strut: 3 in

Min. overlap with strut: 40 in

Weld (pipe to connector): 0.75 in

Stiffeners

	Stiffener Name	Location	Thick (in)	Height (in)	Width (in)
▶	PL1_T	Top	1.625	7.79	33.98
	PL1_B	Bottom	1.625	7.79	33.98
	PL2_T	Top	1.625	7.79	33.98
	PL2_B	Bottom	1.625	7.79	33.98

9.5.10 Keep it Simple

The diagram shows a structural connection with a horizontal beam of length 24.609ft and a vertical column of height 12.304ft. A diagonal member, labeled A1: W36x361, is connected to the beam. The software interface for defining this section is shown below:

Strut Sections

Strut Sections: PP30x0.5, PP24x0.500, W36x361

A. Type-Dimensions

1. Name: W36x361

2. Section Type:

- Use a steel I-Section: W36x361
- Use a pipe section
- Use hollow sections

Section Rotation:

- Flat
- Vertical

Double member options:

- Single member
- Double member

Steel material: A50

Model strut section as non-yielding (in nonlinear analysis)

Edit strut properties manually

3. Section Dimensions - Mechanical Properties

D	38	in	A	106	in ²	f _y	50	ksi	E	29000	ksi	r _x	15.6	in
b _f	16.7	in	t _f	2.01	in	t _w	1.12	in	k	2.96	in	r _y	3.85	in
b _x	25700	in ⁴	I _{yy}	1570	in ⁴	J	109	in ⁴	W	361	plf	r _T	4.42	in
S _{xx}	1350	in ³	S _{yy}	188	in ³	Z _{xx}	1550	in ³	Z _{yy}	293	in ³	C _w	509000	in ⁶

Steel Connection Data

Name and section type: Name: WALE: A 0-STRUT: A1, Stiffener status: []

Horizontal angle: 45 deg, Max. weld stress check (all stages): []

Input Stage Results

Connection Options: Weld Size: 0.8125 in, Selected Welds: [Diagram of H-section with welds]

Connection Stub: Type: No stub (member connects directly)

Stiffeners

Stiffener Name	Location	Thick (in)	Height (in)	Width (in)
PL1_T	Top	1.625	7.79	33.98
PL1_B	Bottom	1.625	7.79	33.98
PL2_T	Top	1.625	7.79	33.98
PL2_B	Bottom	1.625	7.79	33.98

Weld Size: 0.75 in, Remove stiffeners: []

9.6 Frame Options to reduce moments

- Corner arching effects (EAB)
- Clear span points on walers at struts (mid point or edges)
- Waler points of rotation
- Splays

10.0 3D FEM Analysis

- Wizards generate quick models
- Wall perimeters – wall segments
- Walers
- Struts
- Anchors
- External 3D loads

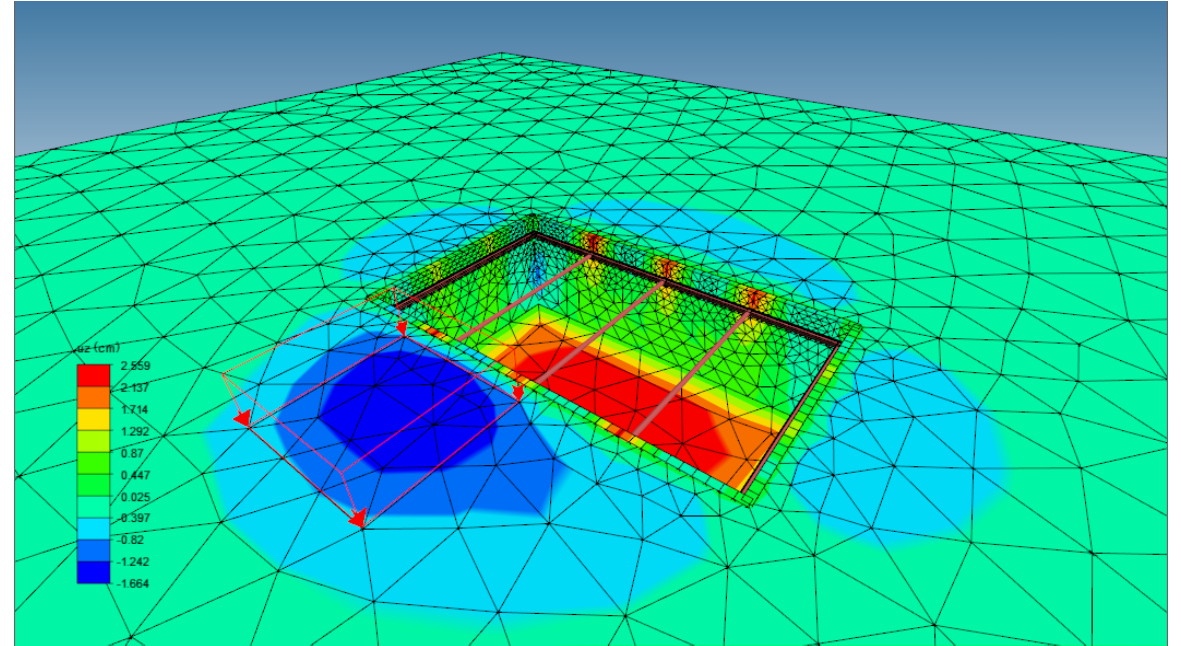

10.1.0 General FEM3D Settings

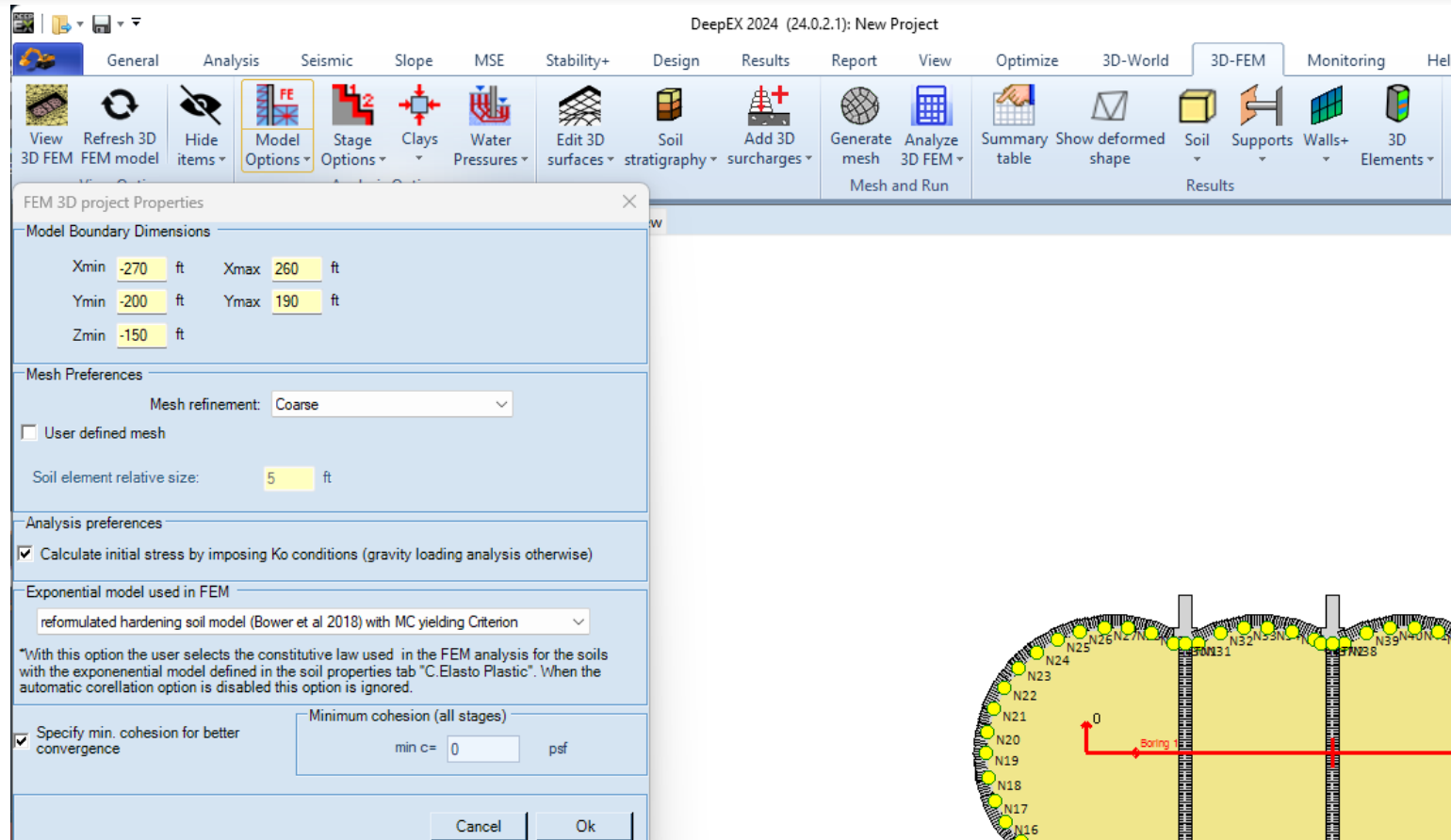

10.2.0 Wall Properties for 3D FEM

- FEM3D tab on wall sections

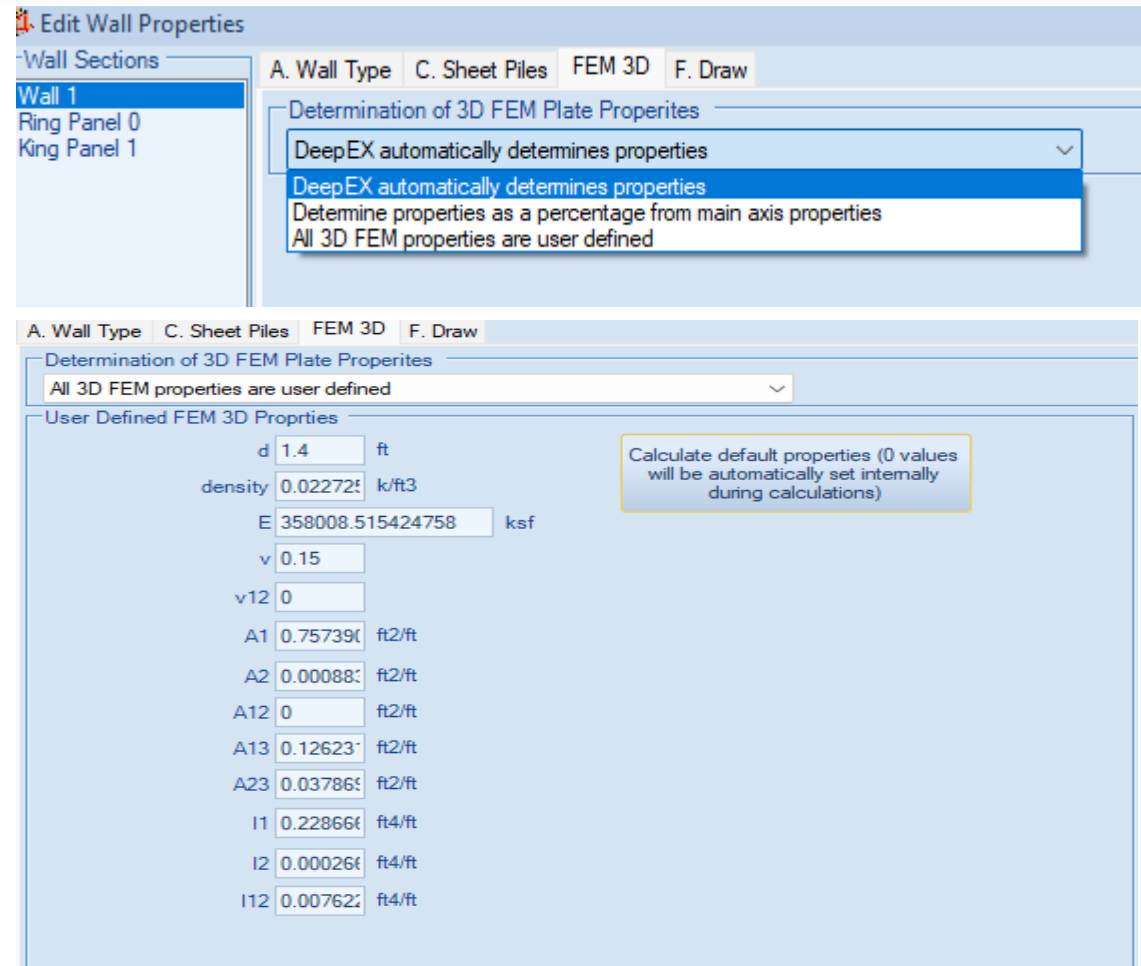

10.3.1 Wall Perimeter – Segment Options

- Unlink from 2D design section (for structural properties)
- Length options (wall depth)

The screenshot shows the 'Edit wall segment' dialog box with the following settings:

- Name: WN32
- Active-Inactive: Wall segment is active for current stage
- Select design section and wall: Don't link wall segment to 2D design section (highlighted with a red underline)
- Use a different design section and wall from the wall perimeter
- Design Section: Base model (dropdown)
- Wall: Wall 1 (dropdown)
- Use worst loading from all linked design sections
- Apply to all segments
- Wall: Ring Panel 0 (dropdown)
- Wall Length L1: 120 ft
- Wall Length L2: 120 ft

At the bottom, there are tabs for: Wall section, Bracing levels, Arching effects, Elevations, Interfaces-FEM3D, and Elements.

10.3.2 Elevations, Interfaces, Elements

Edit wall segment

Name
WN32

Active-Inactive
 Wall segment is active for current stage

Select design section and wall
 Don't link wall segment to 2D design section
 Use a different design section and wall from the wall perimeter

Design Section Base model
Wall Wall 1

Use worst loading from all linked design sections Apply to all segments

Wall Ring Panel 0
Wall Length L1 120 ft
Wall Length L2 120 ft

Wall section Bracing levels Arching effects Elevations Interfaces-FEM3D Elements

These options allows the program to recalculate the top of wall elevations based on the topographical ground survey. The adjustments will take place only if topo points are defined in the initial natural surface at stage 0.

Reset elevations Don't change elevations

Specify start-end elevations

Start-End Elevations
Start EL. 0 ft
End EL. 0 ft

Wall section Bracing levels Arching effects Elevations Interfaces-FEM3D Elements

User defined interface value (otherwise software automatically selected based on wall section)

Connection to previous wall segment Automatically determined

Connection to next wall segment Automatically determined

Wall section Bracing levels Arching effects Elevations Interfaces-FEM3D Elements

These options allow you to add additional wall elements that can be activated or deactivated at different stages.

Name	Top. EL (ft)	Bottom EL. (ft)	Wall section	Options
------	--------------	-----------------	--------------	---------

Add wall element at bottom Add wall element at top Height 10

10.4.0 Wale Segment End Connections

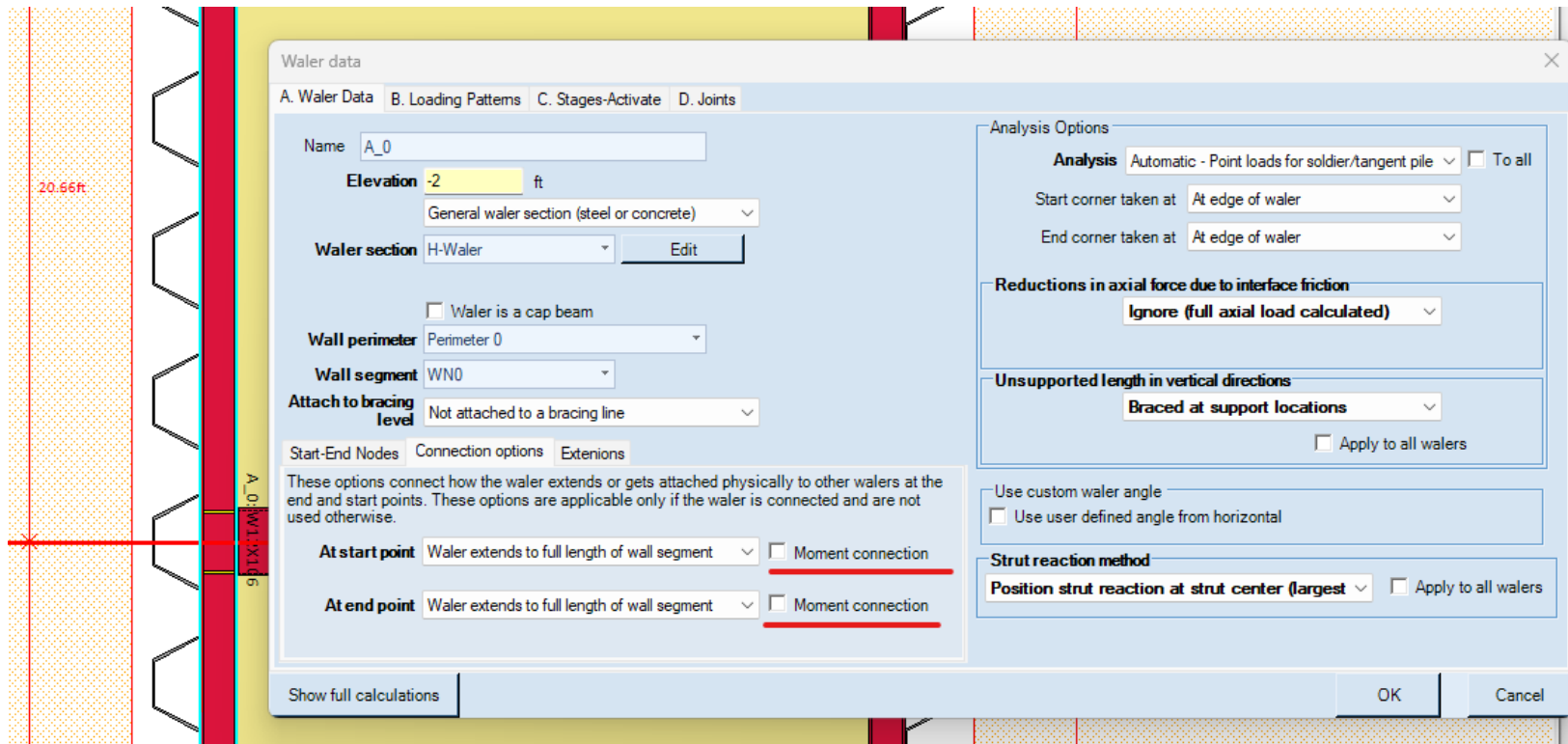

11. 3D City

- Import city buildings, elevations (cadmapper)
- Import utilities
- Generate new tunnel/subway line
- Position stations
- Estimate service level improvements
- Estimate costs & benefit analysis

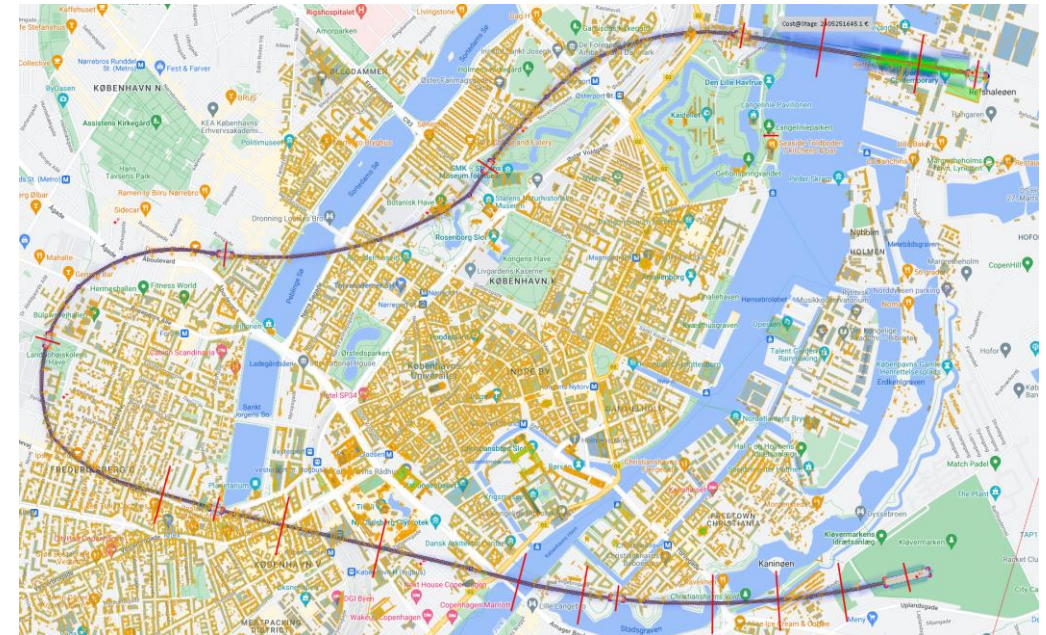

11.1 Set Map Location

Import map image from Google Maps

Map information

Use online map service

Longitude
-118.251450061798

Latitude
34.0455300711071

Zoom level
16

Angle
0

Map type
 roadmap hybrid satellite terrain

Use paid Google Maps Key

Image size (pixels)
width 400
height 400

Process map coordinates

Save Map Image

Set reference point on screen

Project reference coordinates
x ref 0
y ref 0

Set project map reference

Scale factor 1

x Pixel offset 0
y Pixel offset 0

Regenerate image

Map is visible in map

ESPG GEN

Pass map data

Τι αποκάλυψε ο πόλεμος στην C x Create | CADMAPPER x +

← ↻ 🏠 🔒 https://cadmapper.com/pro/home

CADMAPPER

Fr

CREATE MAP

Select your design program

AutoCAD SketchUp 2015+ Ai Illustrator

Rhino 5 ArchiCAD SketchUp 8 to 2014

Other (.DXF) ✓

Include

3D Buildings (if available) Topography

Set false height if no 3D data Contours

10 meters

Road Geometry

Centerlines ▼

Search or input lat,lon...

11.2 Import Cadmapper DXF

Select coordinates UTM

Copy and paste text from CAD-MAPPER website here:

Or fill each Value from dxf map:

Utm Zone

Easting

Northing

Reference Elev.

File Type: Other (.DXF) DXF
Area: 0.913 km²
Buildings: 554 total, 37 with height value (7%)
Topography: Included, 2102.66 m above sea level
Settings: Road centerlines, 3D buildings (no value = 10.0 m)
Spatial Reference System: Meters; UTM zone: 12, easting: 439332.93, northing: 3894319.74

[DOWNLOAD \(220.9 KB\)](#) Download available for 1 week.



Launch Cadmapper.com

OK Cancel

11.3 Draw Subway Lines & Stations

Subway Line Editor
✕

1. Name and Basic Data

Lock item
 Is existing

Purpose Subway

Subway lines can be used to quickly create subway alignments with stations and tunnels for a whole project.

Method TBM Soft Rock, Ground (shiel

2. Data

2.1 Plan Coordinates
2.2 Elevation Profile
2.3 Stations and Shafts
2.4 Section Along Path

	x	y	EL	Shape Type	Station X	Ground EL
▶	-2355.01829502...	989.4079964269...	215	Line	0	269.5496013563...
				Line	878.0180641711...	292.0209313907...
				Arc	1371.215031929...	295.24600646174
				Arc	1624.169699943...	296.4300416073...
				Arc	1785.161748055...	296.53873073519
				Line	1944.936968046...	296.4807861164...
				Line	2854.636195346...	301.9608728118...
				Arc	3043.522056415...	316.3750164948...
				Arc	3486.465125278...	364.8200317424...
				Arc	3856.371555016...	412.1508475058...
				Line	3928.694732770...	415.5537511915...
				Line	4611.507697692	389.6476869290...
				Line	5752.304897661...	289.34244026789
				Line	6879.036780037...	273.3886784410...
				Line	7207.017100226...	266.7905624697...
				Arc	7717.138523910...	271.1033750652...
				Line	8060.525969433...	271.2218318217...
				Line	8349.950088859...	270.89998217153
				Arc	8461.412001346...	271.0025079444...
				Arc	8840.939369047...	271.29345904265
				Arc	9023.228063298...	271.6590926760...
	4053.347141472...	1912.231851283...	215	Line		
*						

Set Elevations From Topo

Depth ft

Slope %

Associated Geological-Geotech Section

Create or regenerate section when form closes

Insert Point At Station

Station ft

Subway Operational Profile (hours of operation and days)

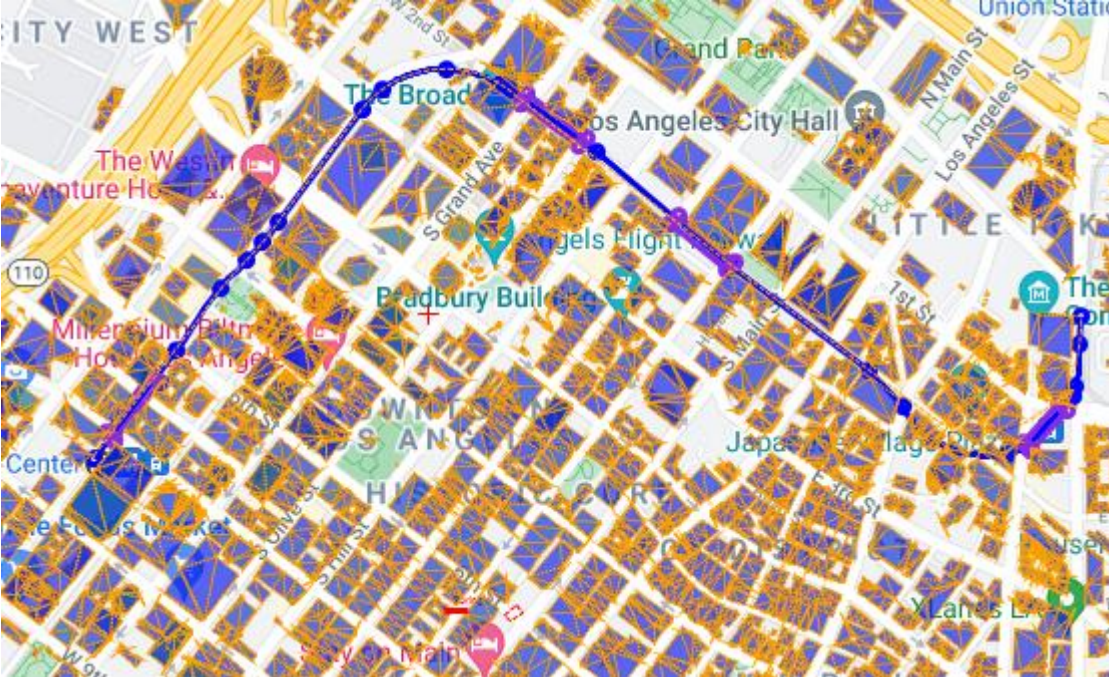

11.4 Tunnel Costs (Planning Level)

REFERENCES\ASCE 2023 Geocongress\230207 LA REGIONAL WITH OP ANALYSIS.DEEP

Results Report View **Optimize** 3D-World Monitoring Help

Estimate project cost

Cost options Tunnel Cost Options Estimate cost (without analyzing model)

Cost Options

Tunnel Cost Estimation

1. Cost Estimation Analysis Type

Analysis Type

2. Planning Level Cost Curve Selection

Cost Curve

Inflation Factor from 2008

Cost Contribution due to Geology (RMR) %

Cost Contribution due Materials %

Cost Contribution due Labor-Equipment %

Location Costs

A cost curve of 100% indicates the most expensive estimate while a cost curve of 0 the cheapest. 50% cost curve indicates an average estimate value. The referenced costs in this approach use 2008 USD. The inflation factor adjusts to today's dollars.

The location defined option will use the local material and labor cost indexes against 100 (Means average cost) to scale the cost curve. Otherwise, use a user specified location factor to adjust for international locations.

11.5 Operational Analysis Settings

The screenshot shows the 'Railway Speed and Turning Radius Profiles' dialog box. The background window is titled 'Subway System Operational Analysis Settings' and shows a wizard with five steps. The dialog box is currently open, showing the following settings:

Profile Name: Default

1. General Speeds and Accelerations

- Max. Operational Speed between stations: 50 mph
- Speed Manoeuvres at Stations: 15 mph
- Entrance Speed at Stations: 27 mph
- Maximum acceleration: 3 ft/sec²
- Basic jerk for linear acceleration: 0.75 ft/sec³

2. Dwell and other time intervals

- Dwell times at stations: 20 sec
- Dwell times at major stations: 25 sec
- Layover time at end station: 180 sec

3. Curves

- Max. tangential non compensated acceleration atcn: 2.1 ft/sec²
- Jerk limit: 2.75 ft/sec³
- Min. turn radius: 150 ft
- Max Speed at Curves: 50 mph

3. Cant settings for curves (superelevation of one rail vs. lower)

Radius (ft)	Cant (in)
0	3.25
1300	3.25
1500	3
1650	2.677
2650	2.25
4000	1
4999	1
5000	0
1000000000000	0

The background window shows the following settings:

1. Select Analysis Method

- Analysis method: Perform detailed train travel analysis and operational costs
- Design Life: 50

2. Select Operational Cost Profile

- Typical

3. Operational Profiles (service per hour)

Name	Edit Options
Typical NYC service profile	Edit
Typical London service profile	Edit
Typical Athens service profile	Edit

4. Select Ridership Response Profile and Fares

- NYC-MTA

5. Detailed Speed Operational Profiles

- Not selected

11.6 Subway Operations & Costs

Subway Operational Cost Profile Settings

Profile Name

Average Inflation %

Annual cost increase due to aging % per year (on tunnel and station maintenance)

1. Train Costs 2. Tunnel Maintenance 3. Station Costs 4. Revenues

Total operating cost for Engine \$/mile

Total operating cost for Coach \$/mile

Travel cost for Engine \$/mile

Travel cost for Coach \$/mile

Purchase cost for Engine \$

Purchase cost for Coach \$

Replacement life for trains Years

Annual vehicle maintenance cost percentage %

Annual vehicle maintenance cost increase (due to aging) %

Subway Operational Profile

Profile Name

Total Vehicles Per Train

Average Speed kPh (Km per h)

Average Express Speed

Reliability Trains (in case there is break down of a running train)

Preventive Maintenance Trains (In maintenance/immobilized >8hrs)

Corrective Maintenance Trains (Trains that are under repair or refurbishment)

List

- Typical 24hr weekend profile
- Typical 24hr daily profile

Daily-Hourly Profile

- Sunday
- Monday
- Tuesday
- Wednesday
- Thursday
- Friday
- Saturday

The operational profiles control the level of service during specific times and days. Operations can be set for partial or full daily service. These profiles can be later used to estimate train travel and operational costs.

	Time Start	Time End	Train Frequency (min)	No service
▶	00:00:00	06:00:00	15	<input type="checkbox"/>
	06:00:00	10:00:00	10	<input type="checkbox"/>
	10:00:00	22:00:00	7.5	<input type="checkbox"/>
	22:00:00	00:00:00	10	<input type="checkbox"/>
*				<input type="checkbox"/>

11.5 Service Level Improvements

Transportation Service Levels

Access Data

	Name	Access Mode	Time Limit Min	People Served	Number Of Access Points	Annual Per Capita Cost Benefit	Total annual cost benefit	Color
▶	Level 1	Walking	5	362434	479	0	90608552	Color
	Level 2	Walking	10	655440	1543	0	98315967	Color
	Level 3	Walking	15	831401	3093	0	83140108	Color
	Level 4	Walking	20	966946	4451	0	0	Color
*								

OK

Routing Services

1. Select Analysis Method

Analysis method

Analysis Options

Limit distance for source points to stations

Limiting Distance Label3

OK Cancel

11.7 Operational Cost Analysis

Subway Operational Cost Analysis Results : Total costs for new and existing lines

1. Table Results 2. Graph Results 3. Train Results 4. Annual Ticket Sales

	Year	Total cost \$ mil.	Train Purchase \$ mil.	Train Operation \$ mil.	Train Travel \$ mil.	Train maintainan \$ mil.	Station Operation \$ mil.	Station Maintenanc \$ mil.	Tunnel Maintainan \$ mil.	Other Costs \$ mil.	Revenue \$ mil.
	From 1 t...	1644.1	331.55	489.44	187.15	135.25	304	357.7	26.16	0	7014.15
	1	88.64	80.5	3.21	1.23	0.8	1.99	1.99	0.15	0	63.81
	2	8.48	0	3.33	1.27	0.84	2.07	2.08	0.15	0	63.81
	3	8.84	0	3.47	1.33	0.88	2.15	2.18	0.16	0	69.55
	4	9.21	0	3.61	1.38	0.93	2.24	2.27	0.17	0	69.55
	5	9.6	0	3.75	1.43	0.97	2.33	2.38	0.17	0	69.55
	6	10.01	0	3.9	1.49	1.02	2.42	2.48	0.18	0	75.81
	7	10.43	0	4.06	1.55	1.07	2.52	2.6	0.19	0	75.81
	8	10.87	0	4.22	1.61	1.12	2.62	2.71	0.2	0	75.81
	9	11.33	0	4.39	1.68	1.17	2.73	2.84	0.21	0	82.64
	10	11.8	0	4.56	1.74	1.23	2.83	2.96	0.22	0	82.64
	11	12.3	0	4.75	1.81	1.28	2.95	3.1	0.23	0	82.64
	12	12.82	0	4.94	1.89	1.35	3.07	3.24	0.24	0	90.07
	13	13.36	0	5.13	1.96	1.41	3.19	3.38	0.25	0	90.07
	14	13.93	0	5.34	2.04	1.48	3.32	3.54	0.26	0	90.07
	15	14.52	0	5.55	2.12	1.55	3.45	3.7	0.27	0	98.18
	16	15.13	0	5.77	2.21	1.62	3.59	3.86	0.28	0	98.18
	17	15.77	0	6	2.3	1.7	3.73	4.04	0.3	0	98.18
	18	16.43	0	6.24	2.39	1.78	3.88	4.22	0.31	0	107.02
	19	17.13	0	6.49	2.48	1.87	4.03	4.41	0.32	0	107.02
	20	17.85	0	6.75	2.58	1.95	4.2	4.61	0.34	0	107.02
	21	18.61	0	7.02	2.69	2.05	4.36	4.82	0.35	0	116.65
	22	19.4	0	7.31	2.79	2.15	4.54	5.04	0.37	0	116.65
	23	20.22	0	7.6	2.91	2.25	4.72	5.27	0.39	0	116.65
	24	21.07	0	7.9	3.02	2.36	4.91	5.5	0.4	0	127.15
	25	21.96	0	8.22	3.14	2.47	5.1	5.75	0.42	0	127.15

OK

Subway Operational Cost Analysis Results : Total costs for new and existing lines

1. Table Results 2. Graph Results 3. Train Results 4. Annual Ticket Sales

	Year	Tickets Yearly	Tickets Monthly	Tickets Weekly	Tickets Daily	Tickets Single
	1	89546	1480244	3179700	3314492	1611223
	2	90441	1495046	3211497	3347636	1627336
	3	91345	1509996	3243612	3381113	1643608
	4	92258	1525096	3276049	3414924	1660045
	5	93181	1540347	3308808	3449073	1676645
	6	94113	1555750	3341897	3483565	1693411
	7	95054	1571308	3375315	3518399	1710346
	8	96004	1587021	3409069	3553583	1727449
	9	96964	1602892	3443160	3589120	1744724
	10	97934	1618920	3477590	3625011	1762170
	11	98913	1635109	3512366	3661261	1779793
	12	99902	1651460	3547491	3697874	1797591
	13	100901	1667975	3582965	3734851	1815566
	14	101911	1684655	3618795	3772200	1833722
	15	102929	1701502	3654983	3809922	1852060
	16	103958	1718517	3691532	3848021	1870580
	17	104998	1735702	3728449	3886502	1889286
	18	106049	1753058	3765733	3925368	1908178
	19	107109	1770590	3803390	3964621	1927261
	20	108179	1788295	3841424	4004268	1946533

12.1 Embankment Wizard

- Embankments with MSE and stone columns

Soil Layers

Available Borings

Boring 1

1. General Boring Information - Coordinates

Name Boring 1

Coordinates X -65.617 ft Y 0 ft

The x coordinate controls where the boring is shown in your design section view. Each design section uses one boring (soil strata). You can use a different boring each design section.

SPT Data Option (Applies to Design Section)

SPT Record Not assigned Add edit SPT records

Pass same SPT log to boring (3D visualizations)

CPT Record Option (Applies to Design Section)

CPT Record Not assigned Add edit CPT records

2. Boring Layers - Layer Elevations

	Top Elev.(ft)	Soil Type	OCR	Ko	Edit
	0	F	1	0.5	Edit
	-10	O1	1	0.562	Edit
▶	-30	S1	1	0.441	Edit
*					

General Analysis Seismic Slope MSE

Model Wizard Tunnel/Utilities Wizard Project Info Move Model Elev. Model Dim.-Limits Soil types

Excavation Wizard
Create 2D-3D quick models with excavation walls and support

Station structure (quick)
Quickly generate the internal concrete structure of a subway station for a design section where there are no slabs

Station structure (full wizard)
Quickly generate the internal basement or station structure with detailed options

Embankment Wizard
Quickly generate an embankment with or without a flood wall or with stone columns

11.2 Embankment Wizard

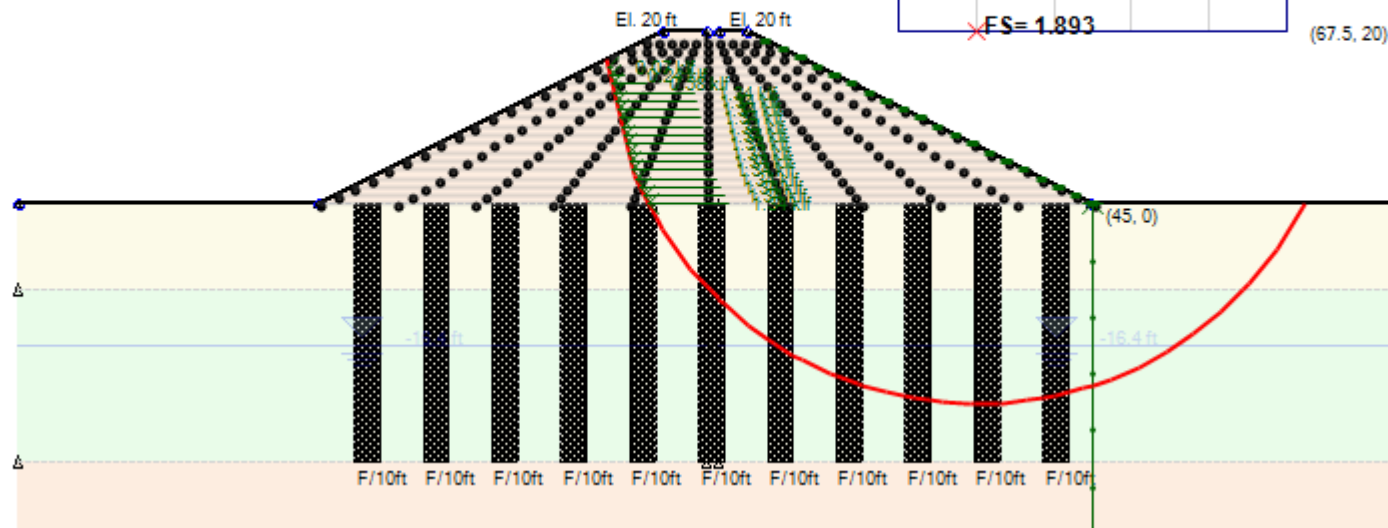
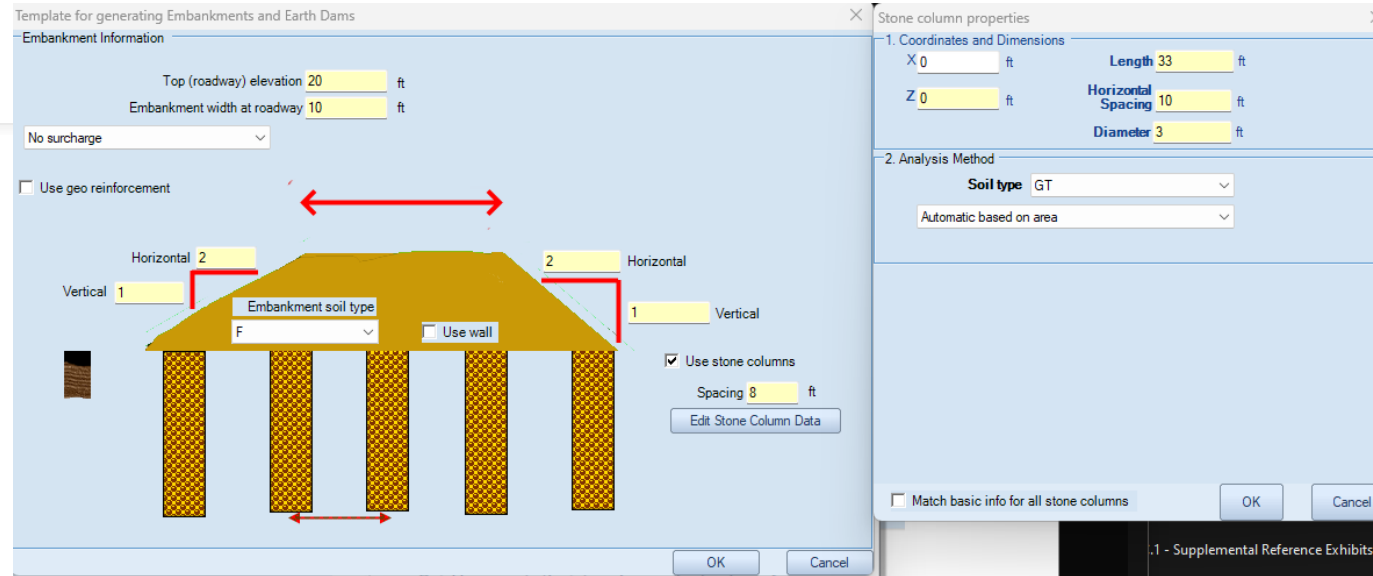

11.0 Conclusion

- Attention to modelling choices in FEM
- Initial state of stress conditions
- Soil loss in tunnelling
- Wave pressures and corrosion for sea walls
- Import buildings from Google Maps and damage assessment
- Steel connections deserve attention